

# BIS NOVA™

## EPA Wood Burning Fireplaces Specifications

Cat.#	Model	Description
BISNOVABK	BISNOVA-BK	BisNova EPA Wood-Burning Fireplace Black
BISNOVABN	BISNOVA-BN	BisNova EPA Wood-Burning F/P Br Nickel

PRODUCT REFERENCE INFORMATION	
Weight	215 lbs
Height	37-5/8"
Width	32-3/4"
Depth	22-1/2"
Firebox W x H x D measured in front	19-1/2" x 13-1/4" x 12"
Chimney Weight ASHT Ø 6"	6.25 lb/ft.
Chimney Weight AC Ø 6"	3.25 lb/ft.
Chimney Weight S-2100+ Ø 6"	10.8 lb/ft.

FRAMING DIMENSIONS		
A	35-7/8"	911 mm
B	37-5/8"	956 mm
C	29-1/8"	740 mm
D	12-1/2"	318 mm
E	70"	1778 mm
F	35"	889 mm
G	*22"	559 mm
J	49-1/2"	1257 mm
K	8"	203 mm

### Framing Dimensions

\* Total depth is 22-1/2 inches (572mm) including the back spacer minus 1/2 inch (13mm) for drywall to be flush with the facing.

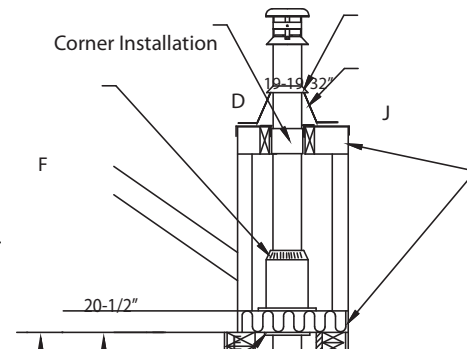
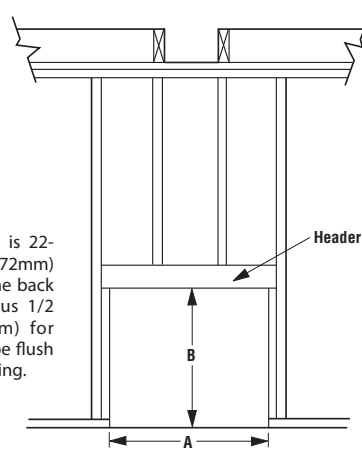
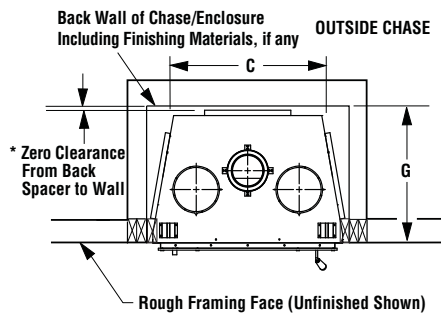

Combustible materials can NOT be used in the space directly above the fireplace. Do not fill the space above the fireplace with any material (Except the wood framing)

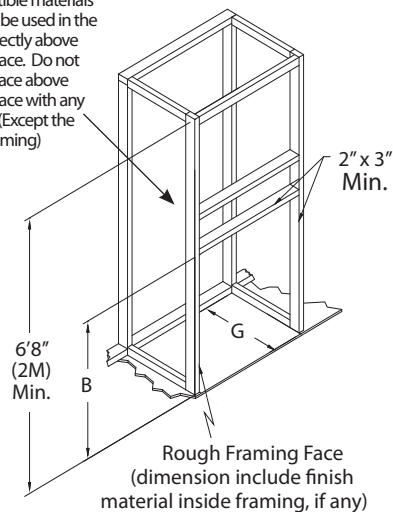

### Optional Combustion Air Kit

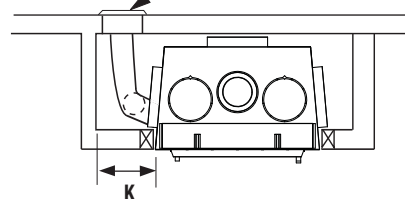

### Notes

Diagrams, illustrations and photographs are not to scale – consult installation instructions. Product designs, materials, dimensions, specifications, colors and prices are subject to change or discontinuance without notice.

All framing dimensions calculated for 1/2" dry wall at the fireplace face. If sheathing the chase or finishing with other thickness materials, calculations will need to be made.

The fireplace must not be in contact with any insulation or loose filling material. Cover the insulation with Drywall panels around the fireplace.

### Listing Information



Listed to standards:  
ULC-S610 & UL-127

### Fireplace Dimensions

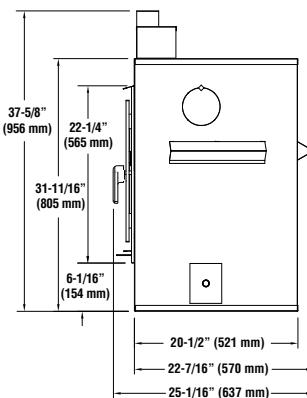
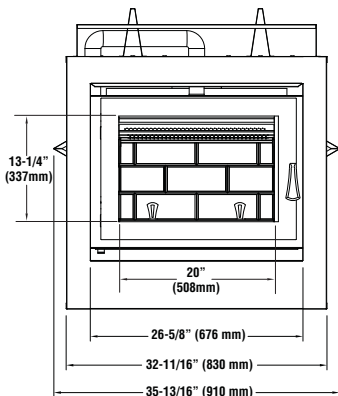
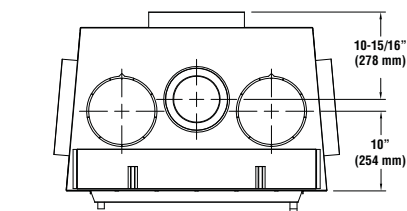

# BIS NOVA™

## EPA Wood Burning Fireplaces Specifications

### Typical Installations

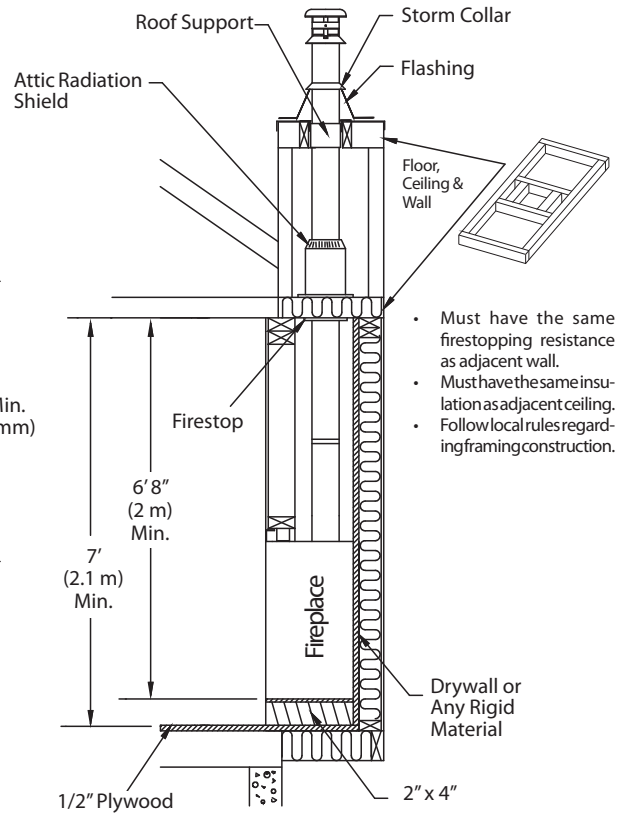
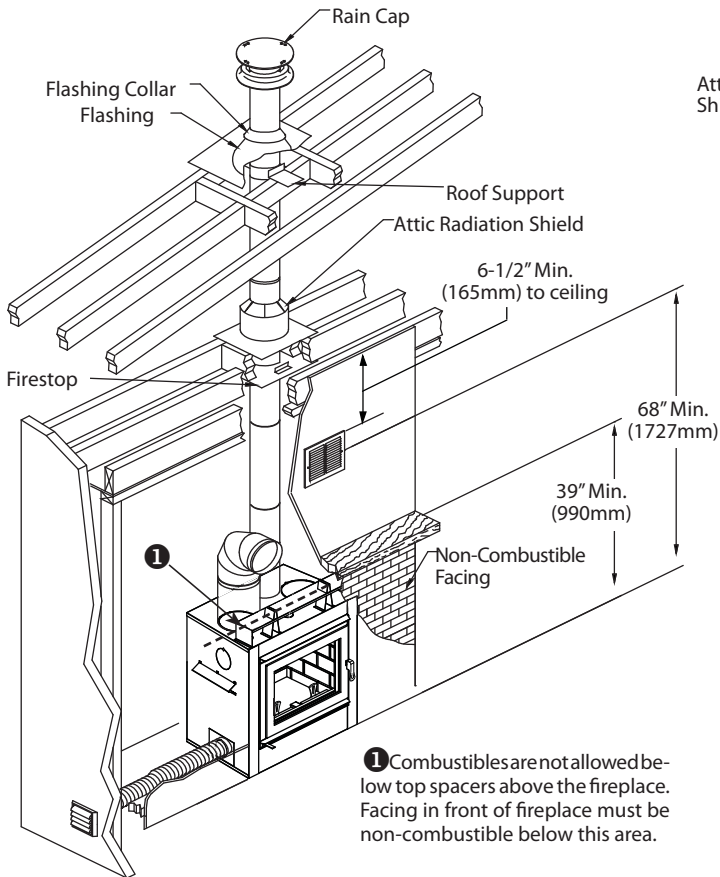

### Combustible Clearances

#### CLEARANCE TO COMBUSTIBLES

The following clearances meet the minimum requirements for a safe installation;

Side wall: 17" (324 mm) measured from the fireplace side

Ceiling: 6' 8" (2,032 mm) measured from the base of the fireplace

Fireplace enclosure:

Bottom: 0"

Side: 0" to spacer

Back: 0" to spacer

Top: Do not fill the space above the fireplace with any material (Except the wood framing - See Page 9, Figure 8 in the Installation and Operation Manual)

Chimney: 2" (50mm)

Mantel: 39" (990mm) measured from the base of the fireplace.

### Hearth Extension and Mantel

