

# INSTALLATION INSTRUCTIONS

## ***Installation And Operation Instructions***

*For Unvented  
Decorative  
Gas Fireplaces*

*Models  
CFST-CMN  
CFST-CMP  
CFPF-CMN  
CFPF-CMP*

**WARNING:** If the information in this manual is not followed exactly, a fire or explosion may result causing property damage, personal injury or loss of life.

– Do not store or use gasoline or other flammable vapors and liquids in the vicinity of this or any other appliance.

### **– WHAT TO DO IF YOU SMELL GAS**

- Do not try to light any appliance.
- Do not touch any electrical switch; do not use any phone in your building.
- Immediately call your gas supplier from a neighbor's phone. Follow the gas supplier's instructions.
- If you cannot reach your gas supplier, call the fire department.

– Installation and service must be performed by a qualified installer, service agency or the gas supplier.

This is an unvented gas-fired heater. It uses air (oxygen) from the room in which it is installed. Provisions for adequate combustion and ventilation air must be provided. Refer to Combustion and Ventilation Air Section, Page 3.

Due to high temperatures, the appliance should be located out of traffic and away from furniture or draperies.

Do not place clothing or other materials on or near this appliance.

PLEASE RETAIN THIS MANUAL FOR FUTURE REFERENCE.

**WARNING: DO NOT USE A BLOWER INSERT, HEAT EXCHANGER INSERT OR OTHER ACCESSORY NOT APPROVED FOR USE WITH THIS HEATER.**



## TABLE OF CONTENTS

General Information .....	page 2
Inventory .....	page 2
Tools and Building Supplies .....	page 2
Installation Applications .....	page 2
Important Safety Information .....	page 2
Codes .....	page 3
Combustion and Ventilation Air .....	page 3
Location of Fireplace .....	page 4
Clearances .....	page 4
Preinstallation .....	page 5
Installation – Built-In .....	page 5
CFST Appliance Specifications .....	page 6
CFPF Appliance Specifications .....	page 7
Connecting Gas Line .....	page 8
Electrical Wiring – Optional Blower ..	page 10
Log Assembly .....	page 10
Flame Appearance .....	page 11
Optional Equipment .....	page 12
Blower Kit .....	page 12
Cleaning and Servicing .....	page 13
Accessories/Components .....	page 14
Operating Instructions .....	page 15
CFST Replacement Parts List .....	page 17
CFST Replacement Parts .....	page 18
CFPF Replacement Parts List .....	page 19
CFPF Replacement Parts .....	page 20
Troubleshooting Guide .....	page 21
Warranty .....	page 24

## GENERAL INFORMATION

The CFST and CFPF Series Unvented Room Heaters covered in this manual feature ceramic fiber split logs which glow realistically when the heater is operating.

These heaters have a standing pilot and are manually controlled through the use of a millivolt gas valve.

A spark ignition system (piezo) allows the heater pilot gas to be lit without the use of matches or batteries and permits operation of the heater during a power outage.

These heaters are fitted with a specially designed pilot (ODS) which responds to the amount of oxygen available in the room and shuts the heater off before the oxygen level drops below 18%. The pilot can be relit only when fresh air is available. Refer to the Combustion and Ventilation Air section.

These heaters may also be equipped with an optional battery powered electronic Carbon Monoxide Safety Shut-Off (COSS) specially designed to respond to the amount of carbon monoxide present in the room air. The carbon monoxide detector will sound an alarm and shut the appliances off within 30 minutes when the amount of carbon monoxide present in the air entering the unit rises above 100 ppm. Time to respond reduces to 15 minutes maximum when carbon monoxide levels exceed 400 ppm.

The CFST and CFPF Series Unvented Room Heaters are designed to be built into a framed wall.

This heater has been tested to the standards of ANSI Z21.11.2 unvented heaters.

Do not install these unvented room heaters in a bedroom or bathroom as all units exceed maximum allowable BTU/Hr input of 10,000.

## Inventory

Unvented Gas Fireplace  
Gas connection fittings  
Installation and Operating Instructions

## Tools and Building Supplies Normally Required

### Tools Should Include:

Phillips screwdriver  
Hammer  
Saw and/or Sabersaw  
Measuring tape  
Electric drill and bits  
Pliers  
Square  
Piping complying with local codes  
Pipe wrench  
Tee joint  
Pipe compound

### Building Supplies Should Include:

Framing materials  
Wall finishing materials  
Caulking materials (noncombustible)  
Fireplace surround materials

Check the inventory list to be sure that you have all the necessary parts in usable condition. Also check for concealed damage.

## IMPORTANT SAFETY INFORMATION

**INSTALLER: PLEASE LEAVE THESE INSTRUCTIONS WITH THE OWNER.**

**OWNER: PLEASE RETAIN THESE INSTRUCTIONS FOR FUTURE REFERENCE.**

**IMPORTANT: BEFORE STARTING YOUR HEATER INSTALLATION, READ THESE INSTALLATION INSTRUCTIONS CAREFULLY TO BE SURE YOU UNDERSTAND THEM COMPLETELY AND IN ENTIRETY. FAILURE TO FOLLOW THESE INSTRUCTIONS COULD CAUSE A HEATER MALFUNCTION RESULTING IN SERIOUS INJURY AND/OR PROPERTY DAMAGE.**

## UNVENTED GAS ROOM HEATER SPECIFICATIONS AND TECHNICAL DETAILS

Model No.	Gas Type	Maximum BTU/HR	Valve Operation	Ignition	Manifold Pressure	Gas Inlet Pressure
CFST-CMN CFPF-CMN	Natural	32,000	Hi/Lo	Piezo	3.5" w.c.	Max 7" w.c. Min. 4.5" w.c.
CFST-CMP CFPF-CMP	Propane/ LPG	29,000	Hi/Lo	Piezo	10" w.c.	Max 13" w.c. Min. 11" w.c.

*Note: Test gage connections are provided on the front of the gas control valve (identified A for the manifold side and E for inlet pressure).*

**WARNING: FAILURE TO COMPLY WITH THE INSTALLATION AND OPERATING INSTRUCTIONS PROVIDED IN THIS DOCUMENT WILL RESULT IN AN IMPROPERLY INSTALLED AND OPERATING UNVENTED ROOM HEATER, VOIDING ITS WARRANTY. ANY CHANGE TO THIS HEATER AND/OR ITS OPERATING CONTROLS IS DANGEROUS. IMPROPER INSTALLATION OR USE OF THIS HEATER CAN CAUSE SERIOUS INJURY OR DEATH FROM FIRE, BURNS, EXPLOSION OR CARBON MONOXIDE POISONING.**

**WARNING: THESE APPLIANCES ARE DESIGNED TO OPERATE ON NATURAL OR PROPANE GAS ONLY. THE USE OF OTHER FUELS OR COMBINATION OF FUELS WILL DEGRADE THE PERFORMANCE OF THIS SYSTEM AND MAY BE DANGEROUS.**

**Carbon Monoxide Poisoning:** Early signs of carbon monoxide poisoning are similar to the flu with headaches, dizziness and/or nausea. If you have these signs, obtain fresh air immediately. Turn off the gas supply to the heater and have it serviced by a qualified professional, as it may not be operating correctly.

- Due to high temperatures, the heater should be located out of traffic and away from furniture and draperies.
- Children and adults should be alerted to the hazard of high surface temperatures and should stay away to avoid burns or clothing ignition.
- Young children should be carefully supervised when they are in the same room with the heater.
- Do not place clothing or other flammable material on or near the heater for the purpose of drying.
- Installation and repair should be done by a qualified service person. The heater should be inspected before use and at least annually by a professional service person. More frequent cleaning may be required due to excessive lint from carpeting, bedding material, etc. It is important that control compartments, burners and circulating air passageways of the heater be kept clean.
- Allow the heater to cool before servicing. Always shut off any electricity or gas to the heater while performing service work.
- Do not install these heaters in a bedroom or bathroom.

- The installation must conform with local codes or, in the absence of local codes with the National Fuel Gas Code, ANSI Z223.1.

- The heater and its individual shut-off valve must be disconnected from the gas supply piping system while performing any tests of the gas supply piping system at pressures in excess of ½ psig.

- The heater must be isolated from the gas supply piping system by closing its individual manual shut-off valve during any pressure testing of the gas supply piping system at test pressures equal to or less than ½ psig.

- Any safety screen or guard removed for servicing the heater must be replaced prior to operating the heater.

- Keep heater area clear and free from combustible materials, gasoline and other flammable vapors and liquids.

- Do not use these appliances if any part has been under water. Immediately call a qualified professional service technician to inspect the appliance and to replace any parts of the control system and any gas control which have been under water.

- Test gage connections are provided on the front of the gas control valve (identified A for the manifold side and E for inlet pressure).

- Operation of these catalytic systems at altitude will result in sporadic nuisance outages of the pilot system due to lack of sufficient oxygen, increasing in frequency as the altitude increases above 4,500 feet. Although this situation is not dangerous, pilot outages cannot be tolerated.

- **These catalytic appliances are rated for use at altitudes no greater than 5,500 feet. Do not install and use this appliance in locations in excess of this altitude.**

- Ensure that the heater is clean when operating. Excessive dust accumulation on the burner and logs will increase the amount of carbon monoxide formation and could lead to carbon monoxide poisoning and death.

### CODES

Adhere to all local codes or in their absence the latest edition of The National Fuel Gas Code ANSI Z223.1 or NFPA54 which can be obtained from The American National Standards Institute, Inc. (1430 Broadway, New York, NY, 10018) or National Fire Protection Association, Inc. (Batterymarch Park, Quincy, MA, 02269).

### COMBUSTION AND VENTILATION AIR

This heater shall not be installed in a confined space or unusually tight construction unless provisions are provided for adequate combustion and ventilation air.

Unusually tight construction is defined as construction where:

a. wall and ceilings exposed to the outside atmosphere have a continuous water vapor retarder with a rating of one perm or less with openings gasketed or sealed, and

b. weather stripping has been added on operable windows and doors, and

c. caulking or sealants are applied to areas such as joints around window and door frames, between sole plates and floors, between wall-ceiling joints, between wall panels, at penetrations for plumbing, electrical, and gas lines, and at other openings.

Use the following equations to determine if you have a confined or unconfined space.

1. Determine the volume of space — ft<sup>3</sup>.

Length x Width x Height = \_\_\_\_\_ ft<sup>3</sup>  
(Include adjoining rooms with doorless passageways or ventilation grills between rooms.)

**Example:** 16' (L) x 16' (W) x 8' (H) = 2048 ft<sup>3</sup>

2. Divide the volume of space by 50 ft<sup>3</sup> to determine the maximum BTU/Hr the space can support.

\_\_\_\_\_ (volume of space – ft<sup>3</sup>) / 50 ft<sup>3</sup> =  
(Maximum BTU/Hr the space can support)

**Example:** 3072 ft<sup>3</sup> / 50 ft<sup>3</sup> = 40.96  
or 40,960 BTU/Hr the space can support.

3. Add the BTU/Hr of all the fuel burning appliances in the space.

Vent-Free heater	_____	BTU/Hr
Gas appliance #1*	_____	BTU/Hr
Gas appliance #2	+ _____	BTU/Hr
Total =	_____	BTU/Hr

**Example:**

CFST/PF heater	34,000	BTU/Hr
Gas appliance #1 (water heater)	32,000	BTU/Hr
Total =		66,000 BTU/Hr

\* Do not include direct-vent gas appliances. Direct-vent is sealed combustion and draws combustion air from the outdoors.

4. Compare the maximum BTU/Hr the space can support with the actual amount of BTU/Hr used.

_____	BTU/Hr
	(max. the space can support)
_____	BTU/Hr
	(actual amount of BTU/Hr used)

**Example:**

40,960	BTU/Hr
	(max. the space can support)
66,000	BTU/Hr
	(actual amount of BTU/Hr used)

The space in the above example is a confined space because the actual BTU/Hr used is more than the maximum BTU/Hr the space can support. You must provide additional fresh air.

**WARNING: IF THE AREA IN WHICH THE HEATER MAY BE OPERATED IS SMALLER THAN THAT DEFINED AS AN UNCONFINED SPACE OR IF THE BUILDING IS OF UNUSUALLY TIGHT CONSTRUCTION, PROVIDE ADEQUATE COMBUSTION AND VENTILATION AIR BY ONE OF THE METHODS DESCRIBED IN THE NATIONAL FUEL GAS CODE, ANSI Z223.1 1992, SECTION 5.3 OR APPLICABLE LOCAL CODES.**

Your options are:

- a. Rework equations adding the space of adjoining room(s). If the extra volume provides an unconfined space, then remove door or add ventilation grills between rooms. Refer to National Fuel Gas Code, ANSI Z223.1 1992, Section 5.3.
- b. Vent room directly to the outdoors. Refer to National Fuel Gas Code, ANSI Z223.1 1992, Section 5.3.

If the actual BTU/Hr used is less than the maximum BTU/Hr the space can support, then the space is an unconfined space. You will need no additional fresh air ventilation for an unconfined space.

**LOCATION OF FIREPLACE**

Carefully select the best location for installation of your CF series Unvented Room Heater. The following factors should be taken into consideration:

- Clearance to side wall, ceiling, woodwork and windows.
- Location must not be affected by drafts caused by kitchen exhaust fans, return air registers for forced air furnaces/air conditioners, windows or doors.
- Installation must provide adequate ventilation and combustion air.
- Do not install these series heaters in a sleeping room or bathroom.
- Never obstruct the front opening of the heater or restrict the flow of combustion and ventilation air.
- This appliance may be installed in an after-market\* manufactured (Mobile) Home, where not prohibited by state or local codes.

\*Aftermarket: Completion of sale, not for purpose of resale, from the manufacturer.

- Minimize modifications to existing construction.

To ensure even heat distribution, it is best to position the heater centrally within the rooms. Make sure there is adequate ventilation where the heater is installed. The gas appliance will shut off if the oxygen level falls below 18%.

These appliances are uniquely suited for installations requiring a utility shelf positioned directly above the fireplace. Utility shelves like these are commonly used for locating television sets and decorative plants.

To provide for the lowest possible shelf surface, combustible materials used to support a utility shelf directly above these appliances should be positioned just above the appliance top spacers. The minimum height from the base of the appliance to the underside of combustible materials used to construct a utility shelf is 42 3/4" (1086 mm).

The appliance should be mounted on a fully supported base extending the full width and depth of the unit. The appliance may be located on or near conventional construction materials. However, if installed on combustible materials, such as carpeting, vinyl tile, etc., a metal or wood barrier covering the entire bottom surface must be used.

If the appliance is to be elevated above floor level, a solid continuous platform must be constructed.

**WARNING: MAINTAIN MINIMUM CLEARANCES.**

Do not install in the vicinity of gasoline or other flammable liquids. The heater must be kept clear and free from these combustible materials and may not be located near where they are stored.

**Clearances**

**WARNING: DO NOT INSTALL CF SERIES UNVENTED ROOM HEATERS IN SLEEPING QUARTERS, OR IN RECREATIONAL VEHICLES.**

**WARNING: DO NOT INSTALL THE CF UNVENTED ROOM HEATER:**

- WHERE CURTAINS, FURNITURE, CLOTHING OR OTHER FLAMMABLE OBJECTS ARE LESS THAN 42" FROM THE FRONT OF THE UNVENTED ROOM HEATER.
- IN HIGH TRAFFIC AREAS.
- IN WINDY OR DRAFTY AREAS.

Ensure the minimum clearances shown in Figures 1 and 2 are maintained.

Combustible mantles may be installed above the appliance (as shown in Figure 1). The mantle projection may be extended beyond 12" if the height above the firebox opening is increased proportionately as detailed by the increments shown.

Minimum clearance to combustibles are:

Appliance: side and back - 0"  
 floor - 0"  
 adjacent wall - 6"  
 ceiling - 41 5/8" (1210 mm)

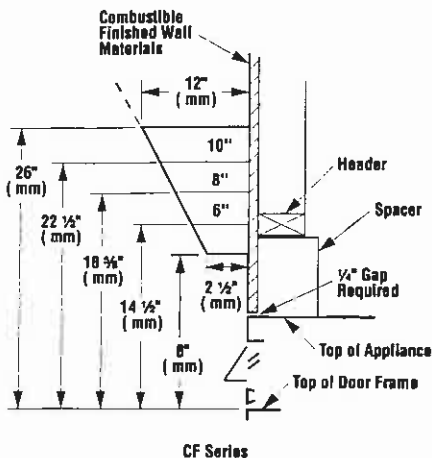

Figure 1

A hearth extension is not required with this appliance. If a hearth extension is used, do not block the lower control compartment door. Any hearth extensions used is for appearance only and does not have to conform to standard hearth extension installation requirements.

*Note: Combustible wall finish materials and/or surround materials must not be allowed to encroach the area defined by the appliance front face (black sheet metal). Never allow combustible materials to be positioned in front of or overlapping the appliance front face.*

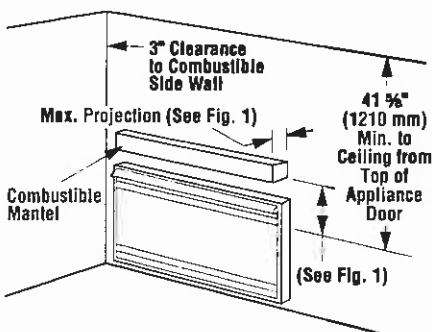

Figure 2

## PREINSTALLATION

Check that all listed parts have been received.

Carefully inspect the heater case and contents for shipping damage and immediately inform the dealer from whom you purchased the gas fireplace if any damage is found.

The appliance is shipped with all gas controls and components installed and pre-wired. Remove the shipping carton, exposing the optional (if installed) front glass door frame. Loosen and remove the three (3) 1/4"-20 x 1" Phillips pan head screws at the three (3) tabs located along the door frame top edge. Tilt the glass door frame assembly outward and disengage the three (3) tabs along the bottom of the door from the three (3) brackets at the bottom of the firebox opening. Remove the door and set the panel aside protecting it from inadvertent damage. Retain the three (3) screws for use on reassembly. Remove the logs, wrapped and secured inside the firebox, and also set aside.

## Check Gas Type

This appliance can only be connected to the gas type specified on the appliance data plate. This appliance can not be modified in the field for a different gas type. If the gas type to be used is not the one specified contact the dealer to obtain the correct gas appliance.

*Note: Illustrations shown in this manual reflect "typical" installations with nominal dimensions and are for design and framing reference only. Actual installations may vary due to individual design preferences. However, always maintain minimum clearances to combustible materials and do not violate any specific installation requirements.*

*Note: The following steps represent the normal sequence of installation. Each installation is unique, however, and might require a different sequence.*

**CAUTION: HEATERS CREATE WARM AIR CURRENTS. THESE CURRENTS MOVE HEAT TO WALL SURFACES NEXT TO HEATER. INSTALLING HEATER NEXT TO VINYL OR CLOTH WALL COVERINGS OR OPERATING HEATER WHERE IMPURITIES IN THE AIR (SUCH AS TOBACCO SMOKE) EXISTS, MAY DISCOLOR WALLS.**

## ASSEMBLY STEPS

The typical sequence of installation follows, however, each installation is unique resulting in variations to those described.

1. Construct the appliance framing.
2. Route gas supply line to appliance location.
3. Install nailing flanges. Install the hoods.
4. Position the appliance within the framing and secure with nailing brackets.
5. Make connection to gas supply.
6. Wiring.
7. Install the operating control switch and bring in electrical service line for forced air circulating blower (optional equipment).
8. Mount forced air kit (optional equipment).
9. Install the logs and Rockwool.
10. Checkout appliance operation.
11. Install glass door frame assembly.

## INSTALLATION STEPS

### Built-In Systems

**WARNING: DO NOT ALLOW FANS TO BLOW DIRECTLY INTO THE FIREPLACE. AVOID ANY DRAFTS THAT ALTER BURNER FLAME PATTERNS.**

**WARNING: DO NOT USE A BLOWER INSERT, HEAT EXCHANGER INSERT OR OTHER ACCESSORY NOT APPROVED FOR USE WITH THIS HEATER.**

Do not burn solid fuels in this listed unvented gas room heater.

*Note: Appliance Dimensional Specifications are shown in Figure 3.*

**Step 1.** Frame the CFST appliance as illustrated in Figures 4 and 5. Frame the CFPF appliance as illustrated in Figures 7 and 8.

The header may be in direct contact with the top metal spacers, but must not rest on them or be notched to fit around them. All construction above the appliance must be self-supporting. **DO NOT** use the appliance for structural support of weights in excess of 250 lbs.

## CFST APPLIANCE SPECIFICATIONS

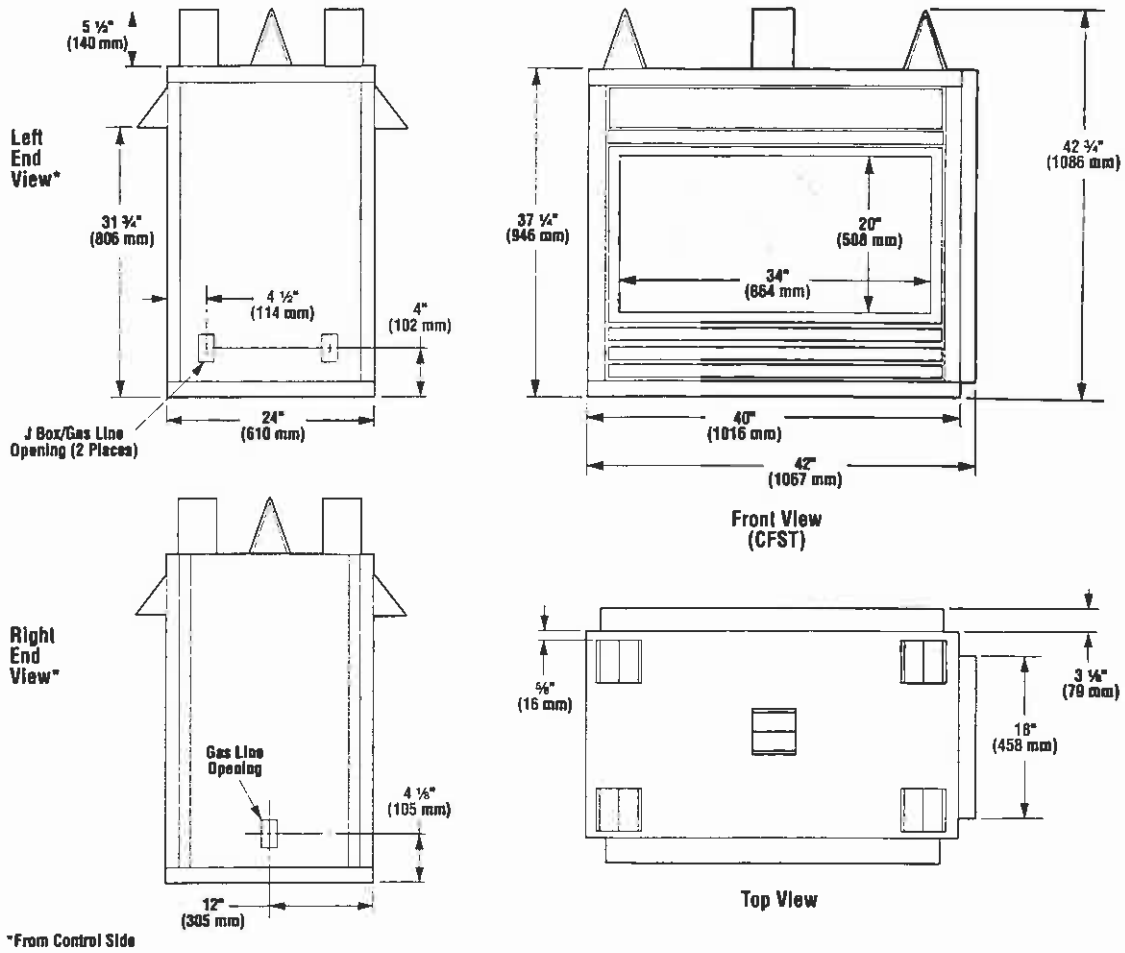

Figure 3

## CFST FRAMING SPECIFICATIONS

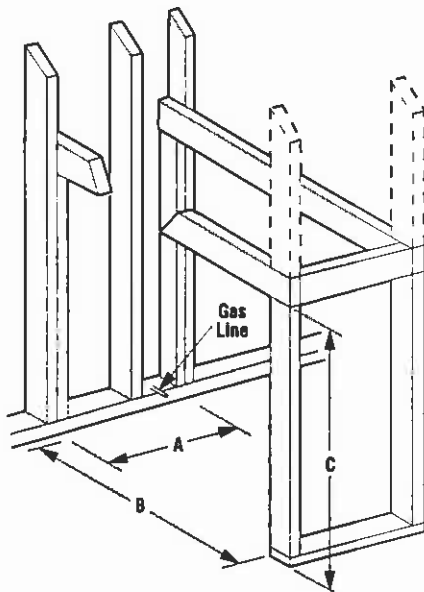

Figure 4

### Framing Dimensions

A	22 3/4" (578 mm)*
B	43" (1092 mm) Min.
C	43" (1092 mm) Min.

\*Note: Framing dimensions calculated for 3/8" drywall finish.

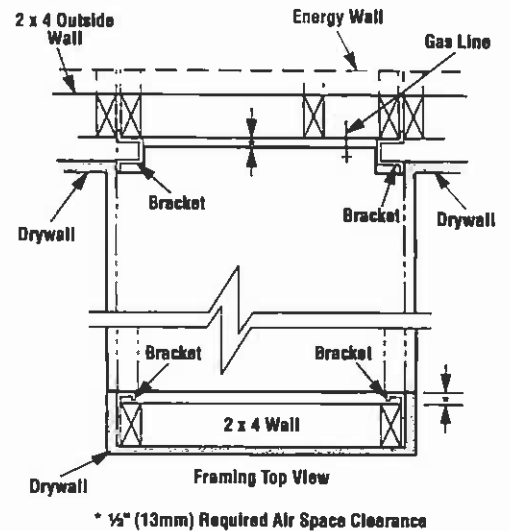

Figure 5

# CFPF APPLIANCE SPECIFICATIONS

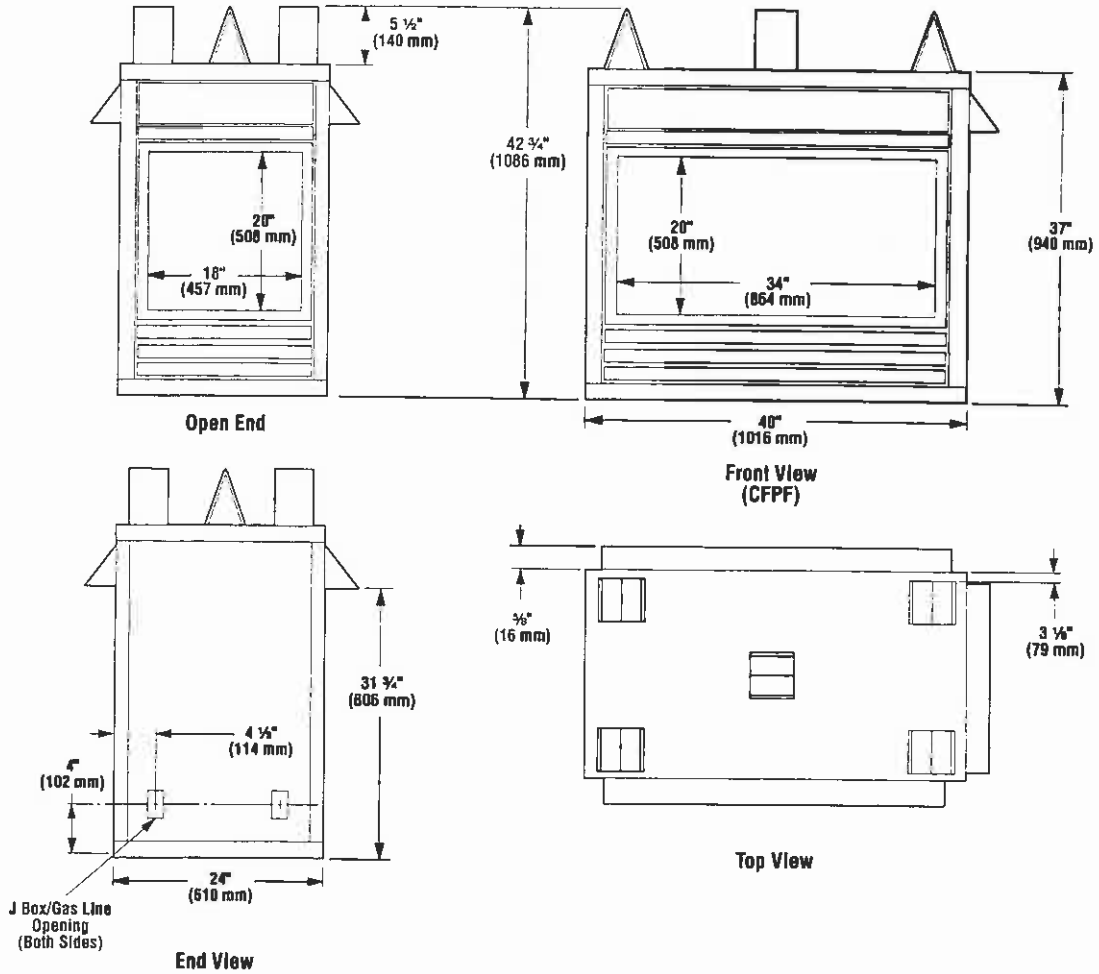

Figure 6

# CFPF FRAMING SPECIFICATIONS

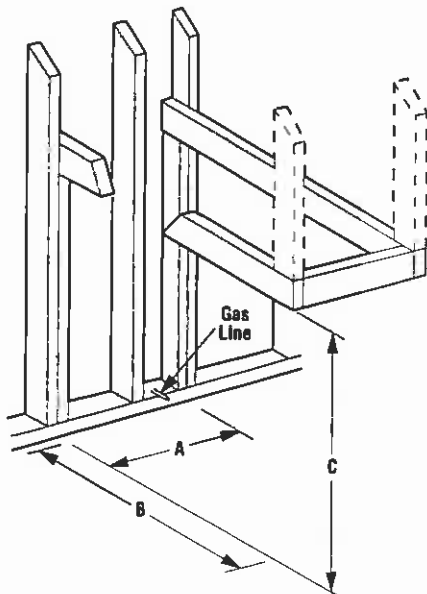
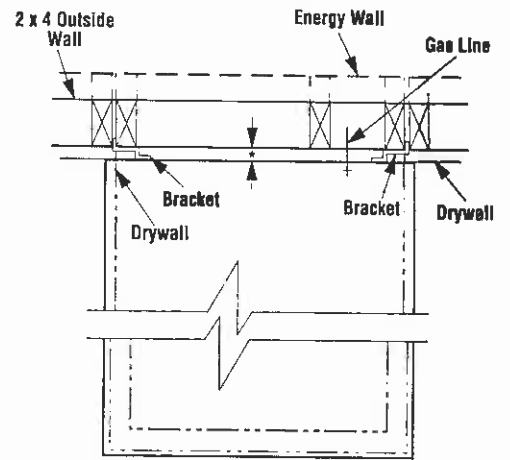

Figure 7

## Framing Dimensions

A	22 3/4" (578 mm)*
B	40 1/8" (1016 mm) Min.
C	43" (1092 mm) Min.

\*Note: Framing dimensions calculated for 5/8" drywall finish.



Framing Top View  
\* 1/2" (13mm) Required Air Space Clearance

Figure 8

**Step 2.** Route a  $\frac{1}{2}$ " (13 mm) gas line along the left or right side framing (Figure 9).

All appliances have a 3" long  $\frac{3}{8}$ " NPT nipple installed at the valve. To quickly and easily complete the gas line routing, use the gas flex line kit, Model GFLV.

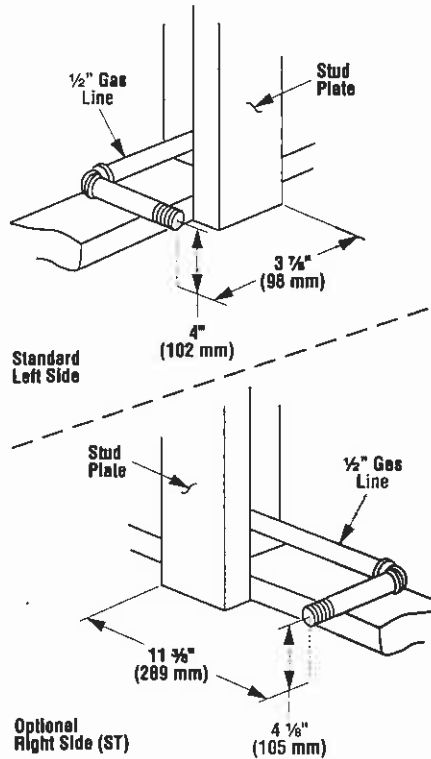

Figure 9

**Step 3.** Remove the nailing flanges from the lower control compartment and install in place with three (3) screws each. Align with the three holes on each side of the appliance (refer to Figure 5).

Install the hood on all units. Position the hood in the open area above the appliance door. Insert the tabs, on each end of the hood, into the bracket at each end. Bend the two tabs over to secure.

**Step 4.** Position appliance into prepared framing, secure with 6d nails at the nailing flange along each side.

**Step 5. Connecting Gas Line –** Make gas line connections. All codes require a shut-off valve mounted in the supply line. Figure 10 illustrates two methods for connecting the gas supply. Installation methods and materials must be in compliance with local codes.

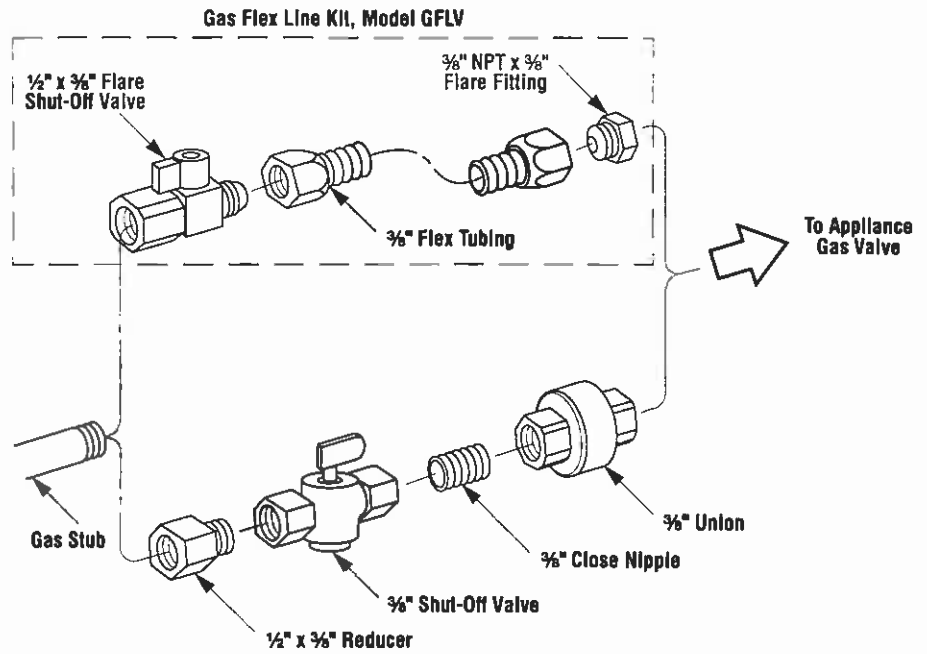

Figure 10

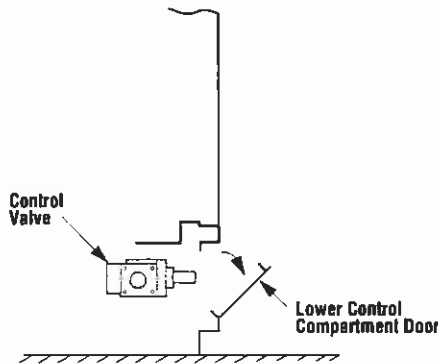

Figure 11

The gas control valve is located in the lower control compartment. To access the valve open the lower control compartment door (Figure 11).

The control valve has a  $\frac{3}{8}$ " NPT thread inlet port and is fitted with two elbows and a nipple to provide the necessary offset. Plan your connections accordingly.

Secure all joints tightly using appropriate tools and sealing compounds (ensure propane resistant compounds are used in propane applications). Turn on gas supply and test for gas leaks using a soapy water solution. **Never use an open flame to check for leaks.**

- A. Mix a 50% dish soap, 50% water solution.
- B. Light the appliance (refer to safety and lighting instructions on page 15).
- C. Brush all joints and connections with the soapy water solution to check for leaks. If bubbles are formed, or gas odor is detected, turn the gas control knob to the "OFF" position. Either tighten or refasten the leaking connection and retest as described above.
- D. When the gas lines are tested and leak free, observe the individual tongues of flame on the burner. Make sure all ports are open and producing flame evenly across the burner. If any ports are blocked, or partially blocked, clean out the ports.

An external regulator must be used on all propane (L.P.G.) heaters, in addition to the regulator fitted to the heater, to reduce the supply tank pressure to 13" w.c. (maximum).

**WARNING: CONNECTING DIRECTLY TO AN UNREGULATED PROPANE TANK CAN CAUSE AN EXPLOSION.**

**Step 6. Wiring –** The wiring diagram is detailed in Figure 12. Refer to Figure 13 to field wire optional wall switch. All electrical wiring must be in accordance with local codes or, in the absence of local codes the latest edition of the National Electrical Code, ANSI/NFPA 70. The heater must be electrically grounded.



**Step 7. Installing the Optional Remote Wall Switch** – The standard millivolt system comes from the factory wired as shown in *Figure 12*. Select a convenient location for the remote wall switch and connect the wiring to the appliance (*Figure 13*).

**CAUTION: DO NOT CONNECT THE OPTIONAL REMOTE SWITCH TO A 120V POWER SUPPLY.**

*Note: The optional rocker switch is mounted to the appliance and wired in the same way as the remote wall switch.*

**Step 8. Installing the Optional Forced Air Blower Kit Wiring** – An electrical outlet box is provided for the installation of the FAB-1100 forced air blower kit (optional). Electrical power must be provided to this box to operate the blower.

Route a 3-wire, 120Vac power line with control switch to the lower right rear corner of the appliance. Make connections to the receptacle as shown in *Figure 14*.

**IMPORTANT: Ground lead must be connected to the green screw on the receptacle. Failure to do so will prevent the appliance from operating.** The appliance must be electrically grounded in accordance with local codes or, in the absence of local codes, the National Electrical Code, ANSI/NFPA 70- latest edition. (In Canada, the current CSA C22-1 Canadian Electrical Code.)

The forced air blower kit may be mounted at initial appliance installation or at any time thereafter. Follow the instructions provided with the blower kit.

**Finished Wall Details**

It is sometimes best to frame the appliance after it has been positioned in place. Frame with 2 x 4s or heavier lumber. Always frame in accordance with local building codes.

*Note: The header may rest on the top spacers but must not be notched to fit around them.*

In order to install the appliance facing flush with the finished wall, position the framework to accommodate the thickness of the finished wall (*Refer to Figures 2, 4, 5, 7 and 8*).

If you live in a cold climate, seal all cracks around your appliance with noncombustible material and wherever cold air could enter the room. It is especially important to insulate outside chase cavity between studs and under floor on which appliance rests, if floor is above ground level.

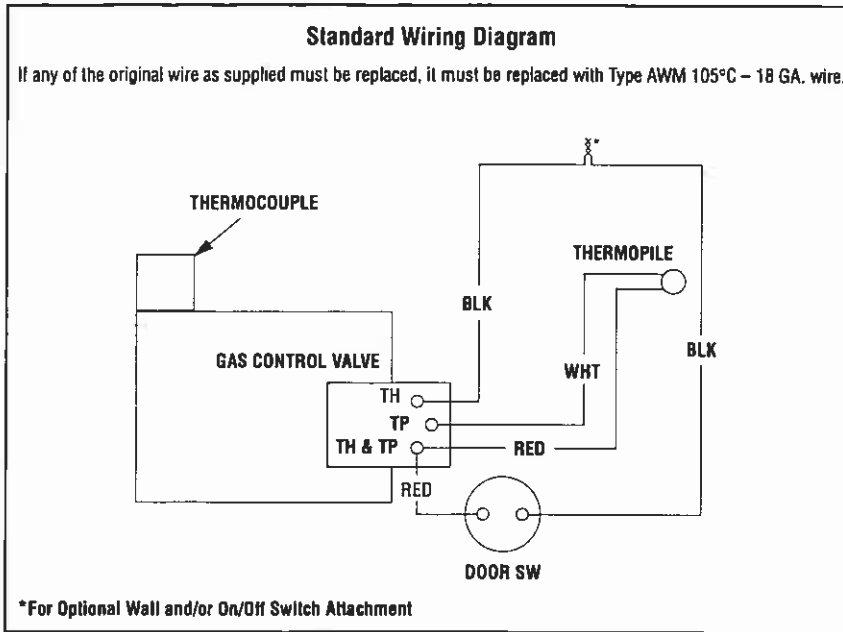

Figure 12

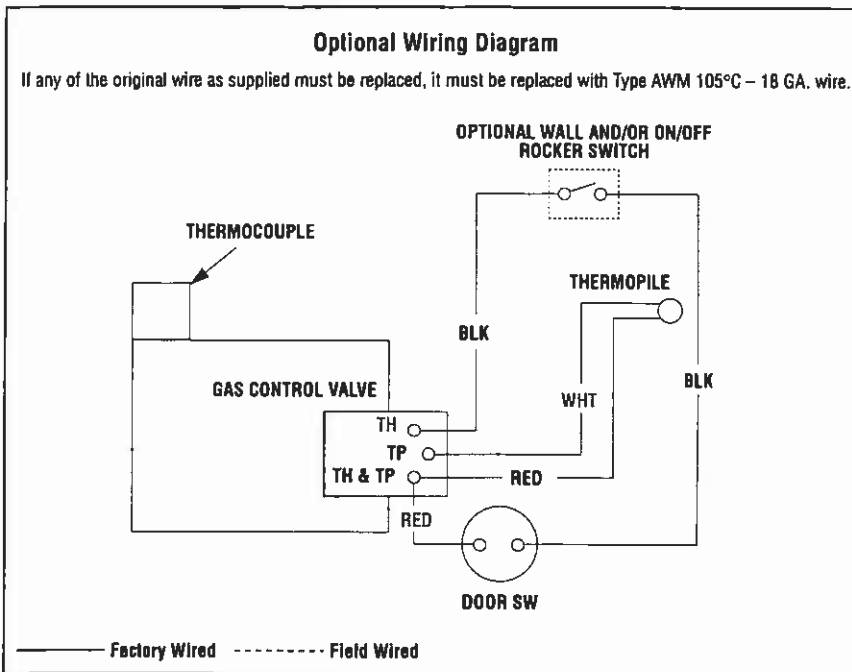
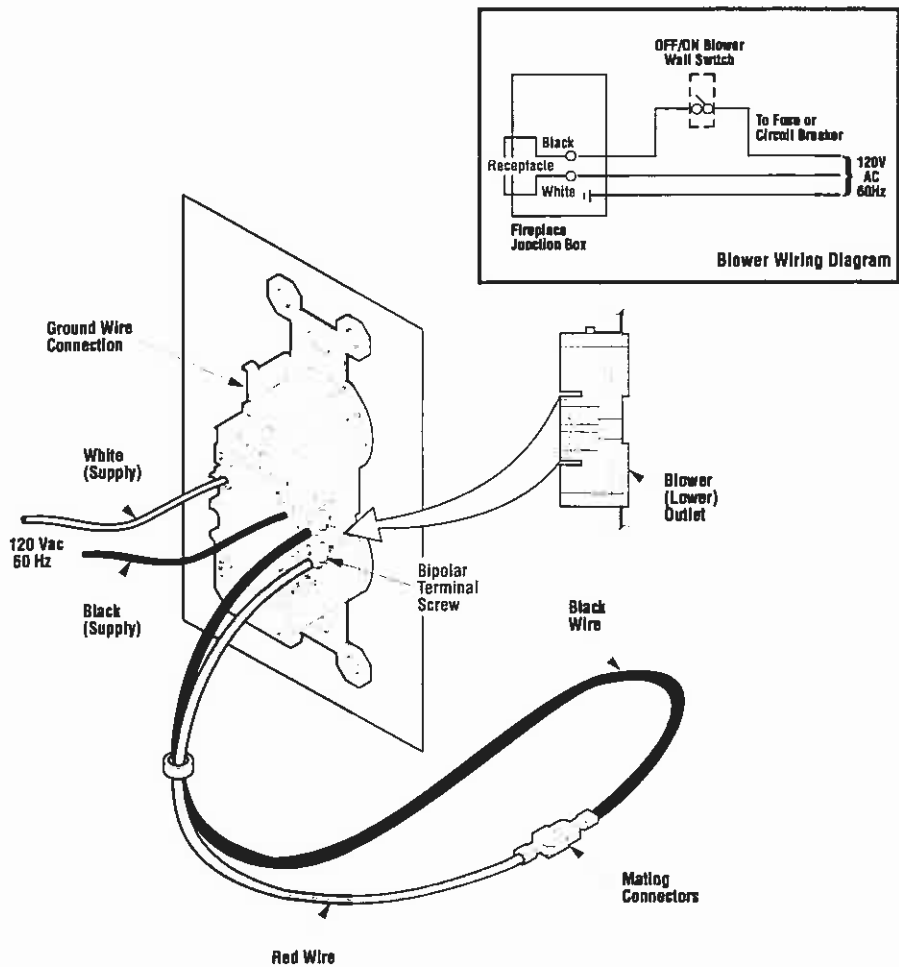

Figure 13

*Note: Supply wires may be alternatively connected to the outlet using the screw terminals, however the black supply wire must be ganged wired to the same terminal that the pre-wired black wire is attached to and the white supply wire must be connected to the opposite side of the outlet.*



**Figure 14**  
Assembling the Logs

**WARNING: DO NOT ADD EXTRA LOGS OR ORNAMENTS SUCH AS PINE CONES, VERMICULITE OR ROCK WOOL. USING THESE ADDED ITEMS CAN CAUSE SOOTING.**

**WARNING: DO NOT PLACE ANY LAVA ROCK ON LOGS OR BURNERS. THIS MAY CAUSE SOOTING.**

**Step 9.** The heater includes a set of ceramic fiber logs. The logs are assembled as shown in *Figure 15*. Handle these logs with great care. The logs can be easily damaged, but when handled properly they can provide years of performance and enjoyment.

Carefully position and center the larger bottom fiber logs onto the burner.

Place the large center fiber log segment #3 between the two (2) lower logs #'s 1 and 2 in the manner illustrated (*Figures 15 & 16A*). The flames should not impinge on the logs.

Position the rockwool over the burner screen as shown in *Figure 16B*.

Install the top four twigs beginning with the left twig #5 first (*Figure 16C*). Shift the lower logs left or right as necessary to align the positioning pins.

Once twig #5 is in position, place the center twig #4 on the set, again adjusting the lower logs left or right as necessary to align the positioning pins.

Position the top twigs #6 and #7 onto the pins of the center twig #4 and onto the pins of the burner.

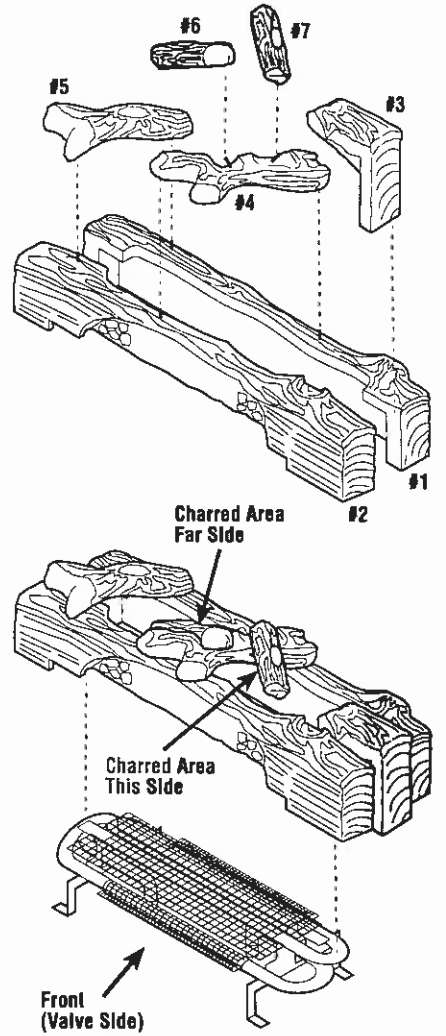

**Figure 15**

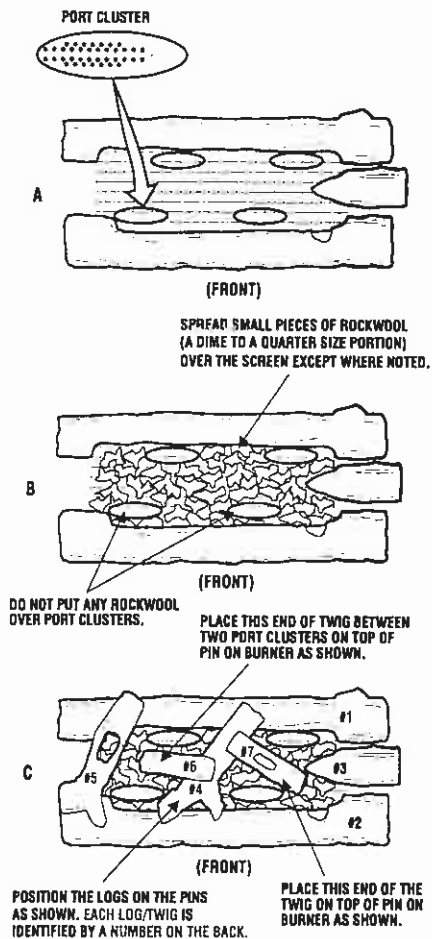

Figure 16

The installation of the logs and twigs, should be complete and resemble Figures 15, 16 and 19.

After settling the logs and rockwool into position as described above, ensure the logs are properly and firmly situated. The heater will not function as intended if the logs are not correctly positioned.

Periodically check the positioning of the logs.

**WARNING: FAILURE TO POSITION THE PARTS IN ACCORDANCE WITH THESE DIAGRAMS OR FAILURE TO USE ONLY PARTS SPECIFICALLY APPROVED WITH THIS HEATER MAY RESULT IN PROPERTY DAMAGE OR PERSONAL INJURY.**

## Flame Appearance

REFER TO THE OPERATING INSTRUCTIONS LOCATED AT THE BACK OF THIS MANUAL BEFORE LIGHTING THE HEATER TO OBSERVE THE FLAMES.

Flames from the pilot, front and rear burner should be visually checked as soon as the heater is installed. In addition a periodic visual check of the flames should be made. The pilot flame should always be present when the heater is in operation and should just envelope the tip of the thermocouple (Figure 17).

**WARNING: NO ADJUSTMENTS ARE TO BE MADE TO THE ODS PILOT SYSTEM. TAMPERING WITH THIS SYSTEM CAN BE EXTREMELY HAZARDOUS.**

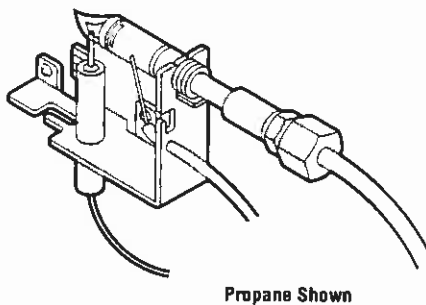

Figure 17

An incorrect pilot flame is shown in Figure 18. This pilot flame will cause the thermocouple to cool. When the thermocouple cools, the heater will shut off. If pilot flame pattern is incorrect, or if heater shuts off, contact your service representative.

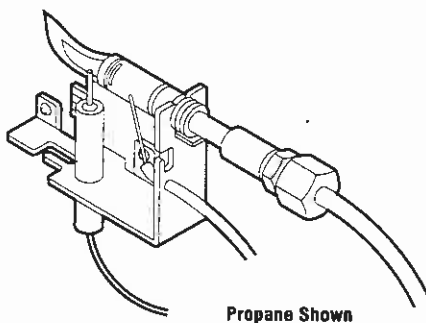

Figure 18

In normal operation, at full rate, after 15 minutes the following flame appearance should be observed:

**Middle Ember Bed Flame Characteristics –** The rear flames should be yellow. The flames should extend about 3 – 4" above the front log for natural gas and 2 – 3" above for propane (L.P.G.) gas (Figure 19).

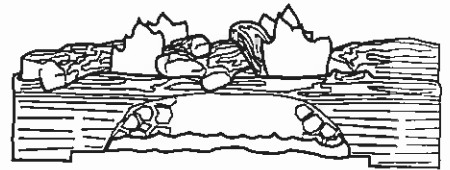

Figure 19

**Left and Right Burner –** The flames at the front burner holes will be blue becoming yellowish as they hit the bark-like texture of the base and front face of the front log (Figure 19).

## Appliance Operation

**WARNING: THE LOWER CONTROL COMPARTMENT AREA AND LOWER CONTROL COMPARTMENT ACCESS DOOR ARE EXTREMELY HOT WHEN THE APPLIANCE IS IN OPERATION. EXERCISE EXTREME CARE WHEN ACCESSING THIS AREA. TOUCH ONLY THE FAR ENDS OF THE LOWER CONTROL COMPARTMENT DOOR WHEN OPENING WHILE THE APPLIANCE IS HOT.**

**Step 10. Checking the System –** With gas line installed run initial system checkout before closing up the front of the unit. Follow the pilot lighting instructions on page 15.

**Note:** Instructions are also found on the pull out panel located on the bottom surface of the appliance.

When first lighting the appliance, it will take a few minutes for the line to purge itself of air. Once purging is complete, the pilot and burner will light and operate as indicated in the instruction manual. Subsequent lightings of the appliance will not require such purging. Inspect the pilot flame (remove logs, if necessary, handling carefully).

Replace logs if removed for pilot inspection.

To light the burner; turn "ON" the optional remote wall switch (if installed) and rotate the gas valve control knob counterclockwise to the "ON" position.

#### Step 11. Installing the Glass Door –

Position the door frame in front of the firebox opening, with the joint in the gasket down. Locate the three (3) tabs at the bottom edge of the door frame into the three (3) brackets at the base of the fireplace front opening. Lean the door frame back towards the fireplace ensuring that the frame seats evenly as it draws shut.

Install the three (3) ¼"-20 x 1" Phillips pan head screws removed previously and tighten to secure. Ensure that the tab on the bottom of the door frame engages the door switch.

Make sure the screws are tightened equally to avoid torquing the door (Figure 20).

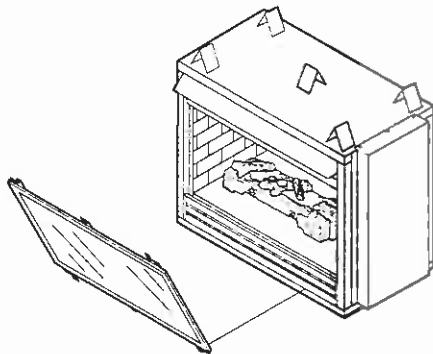

Figure 20

### OPTIONAL EQUIPMENT

An incomparable package of options are available for use with these appliances. These options can both customize the operation of these unique appliances and enhance their beauty and charming appeal. All options are available in kit form, are easy to install and are packaged complete with all required parts and instructions. Some of the option kits need to be fitted prior to completing the installation of the appliance. The following paragraphs detail the kit options available for use with the appliances covered in this manual.

These outstanding optional items can be added individually or in sets of two or more to customize your vent-free appliance to fit your homes unique needs.

The appliances covered in this manual are heater rated and produce a great deal of heat. Decorative brass trim pieces and hoods may tarnish because of their proximity to the heater opening and front face. Tarnishing of these pieces is normal, unavoidable and should be expected.

### Forced Air Kit

The FAB-1100 assembly provides a forced air circulation feature for your appliance. This kit mounts directly into the lower intake chamber with an electrical connection made at the receptacle provided. The appliance must have an independent 120Vac power line incorporated at the time of installation. Refer to Step 6 of the installation instructions supplied with the forced air kit (Figures 21 and 22).

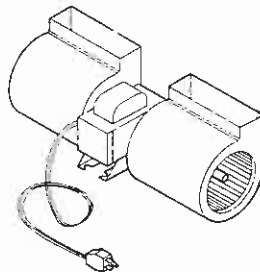

Figure 21

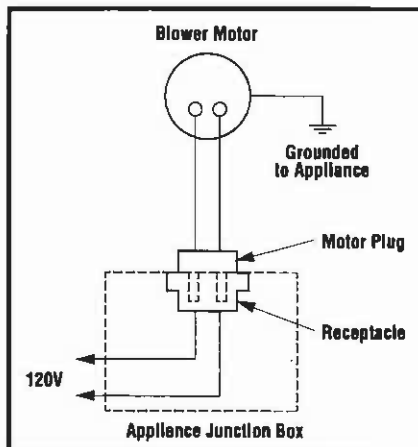

Figure 22

### Remote Control Kit

The Model RCK adds the convenience of remote control for your appliance. The kit includes a wireless, hand held transmitter and a receiver that replaces the wall switch. This special receiver permits either manual or remote control modes. Both receiver and transmitter operate on standard 9 volt batteries (not included). Refer to the RCK installation instruction for specific details.

### Wall Switch Kit

An optional wall switch kit can be installed along with all vent-free appliances. The kit consists of a standard UL wall switch with cover plate. This kit provides for remote (wall) operation of the appliance. Replace the wall switch and cover plate of this kit with the components of the RCK and you can have true remote control of your vent-free appliance, turning it on and off from your favorite easy chair. The wall switch kit should be installed along with the appliance. Refer to Figure 13 and Step 6 for detailed installation instructions.

### Optional on Unil Rocker Switch

An optional rocker switch kit can be installed directly on all CFST and CFPF series appliances to provide for On and Off operation in lieu of a wall switch. This kit is designed to install in the lower control compartment out of view and is perfect for use in high volume areas such as lobbies and model homes where limited access to the appliance On/Off switch is desirable. This kit can be retrofitted to previously installed appliances and may be temporarily installed in place of other switch circuitry.

### Decorative Volcanic Stone

The decorative volcanic stone, Model DVS, can be used to enhance the look of your appliance. Spread the decorative volcanic stone evenly around the bottom of the firebox.

### Screen Panel Kit

An optional screen panel can be installed on the CFST door. This screen panel is easy to install using the provided hardware. This kit can be retrofitted to previously installed CFST appliances. The screen panel kit may not be used in conjunction with either of the decorative arches.

## Decorative Arch Kits

Two arch kits are available for the CFST appliance. A one piece complete door arch kit and a four (4) piece arch frame kit. Both kits are easy to install and do not require hardware to attach them to the standard door frame. The four-piece arch frame kit can be installed without the bottom or bottom and side pieces to customize the look of your appliance. This kit can be retrofitted to previously installed CFST appliances. The decorative arches may not be used in conjunction with the screen panel kit.

## Gas Flex Line with Valve

A gas flex line kit is available to aid in attaching the appliance to the gas supply. This kit can only be used where local codes permit. The kit includes a 1/2" NPT to 3/8" flare in line shut-off valve, a 12" flex line 3/8" female flare through and a 3/8" flare to 3/8" NPT fitting. The components of this kit are rated for both natural and propane gas. This kit is designed to be used as an aid in installing the appliance.

**WARNING: CHILDREN AND ADULTS SHOULD BE ALERTED TO THE HAZARDS OF HIGH SURFACE TEMPERATURES. USE CAUTION AROUND THE APPLIANCE TO AVOID BURNS OR CLOTHING IGNITION. YOUNG CHILDREN SHOULD BE SUPERVISED WHEN THEY ARE IN THE SAME ROOM AS THE APPLIANCE.**

## OPERATION AND CARE OF YOUR APPLIANCE

1. Appliance operation may be controlled through the optional ON/OFF unit rocker switch, located in the lower control compartment, or through a remotely located optional wall switch or wall thermostat. Separate switches may provide independent control for the forced air blower and remote fireplace operation (optional equipment).

2. These heater rated units are equipped with a two stage (HI, LOW) gas control valve. To cycle the burner between the HI and LOW settings, rotate the control knob, located in the center of the valve front face, clockwise and counter-clockwise respectively.

3. When lit for the first time, the appliance will emit a slight odor for an hour or two. This is due to the "burn-in" of the internal paints and lubricants used in the manufacturing process. Additionally, when lit for the first time, this appliance may produce smoke, this is normal and should be expected. For the first few hours, operate the appliance with doors and windows open to encourage the dissipation of smoke and fumes.

4. Upon each lighting of the appliance, condensation may occur and fog the inside of the glass panel. This condition will disappear shortly as the appliance heats.

5. Keep lower control compartment clean by vacuuming or brushing at least twice a year. More frequent cleanings may be required due to excessive lint from carpeting, bedding materials, etc. It is important that the control compartments, burners and circulating air passageways of the heater be kept clean.

6. Always turn off gas to pilot before cleaning. Before relighting, refer to the lighting instructions in this manual. Instructions are also found on a pull-out panel located on the floor of the appliance.

7. Always keep the appliance area clear and free from combustible materials, gasoline and other flammable liquids.

8. Remember, this appliance has a continuous burning pilot flame. Exercise caution when using products with combustible vapors.

## CLEANING AND SERVICING

**WARNING: TURN OFF THE UNVENTED GAS ROOM HEATER AND ALLOW TO COOL BEFORE CLEANING.**

Only limited cleaning will be required under the normal use of the heater. Dust the front grate, the top of the piezo cover and the control knob occasionally. Do not use cleaning fluids to clean the logs or any other part of the room heater.

Remove the log assembly, gently handling by holding each log at each end. Use a vacuum cleaner to remove loose particles from the base and from around the burners. Gloves are recommended to prevent the fibers from pricking your skin. If the skin is pricked, wash gently with soap and water. Replace the logs as detailed in Step 9 Assembling the Logs.

If, after a period of use, the flames start to exhibit unusual shapes and behavior, or the burners fail to ignite smoothly, then the burner holes may require some cleaning. If this happens, it is preferable to contact your nearest dealer to get the appliance serviced.

## REPLACEMENT PARTS

An exploded view of the room heater with numbered parts and a parts list can be found on pages 18 and 20. All parts should be ordered through your Superior distributor or dealer. Parts will be shipped at prevailing prices at time of order.

When ordering repair parts, always give the following information:

1. The model number of the heater.
2. The serial number of the heater.
3. The part number.
4. The description of the part.
5. The quantity required.
6. The installation date of the heater.

If you encounter any problems or have any questions concerning the installation of this heater, please contact your distributor. For the name of your nearest distributor contact:

SFC  
1110 West Taft Avenue  
Orange, CA 92865

**ACCESSORIES AND COMPONENTS**

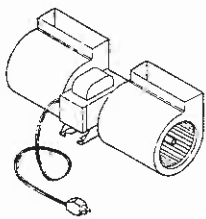

**Forced Air Kit** **FAB-1100**

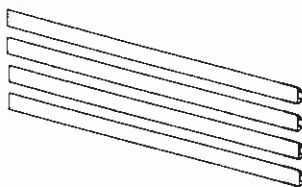

**Brass Louvers**  
-Main Panel **VF6-BRLK**  
-End Panel **VF6-BRLEK**

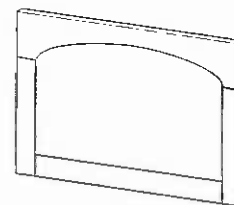

**4-Piece Decorative Arch Frame Kit**  
-Main Panel **DAT-6-4**  
-End Panel **DAET-6-4**

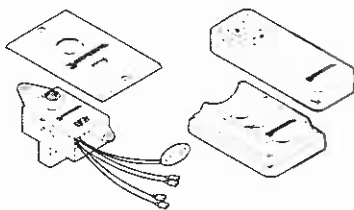

**Remote Control Kit** **RCK**

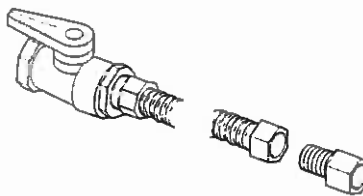

**Gas Flex Line Kit** **GFLV**

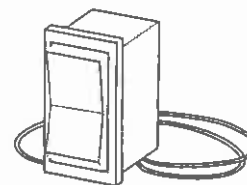

**Rocker Switch Kit** **RS**



**Decorative Volcanic Stone** **DVS**

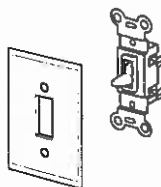

**Wall Switch Kit** **WSK**

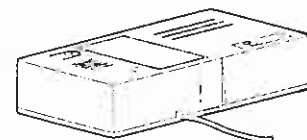

**CO Sensor Kit** **CMSK**

*Note: Model SPK-6 may not be used in conjunction with Models DAT-6-1 or DAT-6-4.*

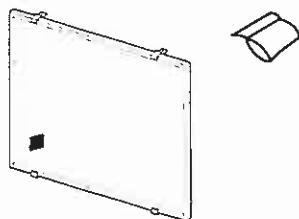

**Screen Panel Kit**  
-Main Panel **SPK-6**  
-End Panel **SPEK-6**

*Note: Model DAT-6-1 may not be used in conjunction with Model SPK-6.*

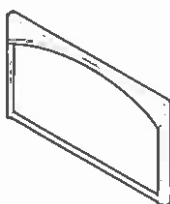

**1-Piece Decorative Arch Frame Kit**  
-Main Panel **DAT-6-1**  
-End Panel **DAET-6-1**

NOTE: DIAGRAMS & ILLUSTRATION NOT TO SCALE.







## OPERATING INSTRUCTIONS

### FOR YOUR SAFETY READ BEFORE LIGHTING

**WARNING: IF YOU DO NOT FOLLOW THESE INSTRUCTIONS EXACTLY, A FIRE OR EXPLOSION MAY RESULT CAUSING PROPERTY DAMAGE, PERSONAL INJURY OR LOSS OF LIFE.**

- A.** This heater has a pilot which must be lit by hand. When lighting the pilot, follow these instructions exactly.
- B. BEFORE OPERATING** smell all around the heater area for gas. Be sure to smell next to the floor because some gas is heavier than air and will settle on the floor.
- WHAT TO DO IF YOU SMELL GAS**
- Do not try to light any appliance.
  - Do not touch any electric switch; do not use any phone in your building.
  - Immediately call your gas supplier from a neighbor's phone. Follow the gas supplier's instructions.
  - If you cannot reach your gas supplier, call the fire department.
- C.** Use only your hand to push in or turn the gas control knob. Never use tools. If the knob will not push in or turn by hand, do not try to repair it, call a qualified service technician. Forced or attempted repair may result in a fire or explosion.
- D.** Do not use this heater if any part has been under water. Immediately call a qualified service technician to inspect the appliance and to replace any part of the control system and any gas control which has been under water.

### LIGHTING INSTRUCTIONS

1. Stop! Read the safety information above.
  2. Make sure manual shut-off valve is fully open.
  3. Locate gas control knob and piezo.
  4. Depress control knob in and turn clockwise  to the "OFF" position (Figure 23).
  5. Wait 5 minutes to clear out any gas. Then smell for gas, including near the floor. If you smell gas, **STOP!** Follow "B" in the safety information above. If you do not smell gas, go to the next step.
  6. The pilot is located on the right side in front of the burner (Figure 24).
  7. Depress control knob in and turn counterclockwise  to the "PILOT" position (Figure 25). Press the control knob all the way in for 5 seconds.
  8. With the control knob pressed in, push in and release the piezo igniter button to light the pilot.
  9. Hold the control knob in for a further 10 seconds to prevent the flame failure detector from shutting off the gas while the probe is warming up.
  10. Release the control knob while turning counterclockwise  to the "ON" Position (Figure 26). Then adjust "HI-LO" knob to preferred setting.
    - If the knob does not pop out when released, stop and immediately call your service technician or gas supplier.
    - If the pilot will not stay lit after several tries, depress and turn the gas control knob clockwise  to "OFF" and wait 30 seconds. Depress and turn knob counterclockwise  to "ON" and press igniter button again. If your pilot does not relight depress and turn control knob clockwise  to "OFF" and call your service technician or gas supplier.
  11. Wait 30 seconds before readjusting the heater when the control knob has been turned down to a lower setting.
- Note: If you are running the heater for the first time it will be necessary to press the control knob all the way in for 30 seconds to allow air to bleed out of the gas piping.*

### TO TURN OFF GAS TO HEATER

1. Depress and turn control knob clockwise  to the "OFF" position (Figure 23).

### MANUAL MATCH LIGHTING PROCEDURE — EMERGENCY ONLY

1. If the pilot cannot be lit with the piezo igniter, the heater can be manually lit with a match.
2. With the right hand, depress and turn the control knob counterclockwise  to the "ON" position. Hold in the knob.
3. Light the match and hold the flame to the end of the pilot and ignite the pilot.
4. Continue to hold control knob for an additional 10 seconds to insure pilot remains lit.
5. Release the control while turning control knob to desired setting.

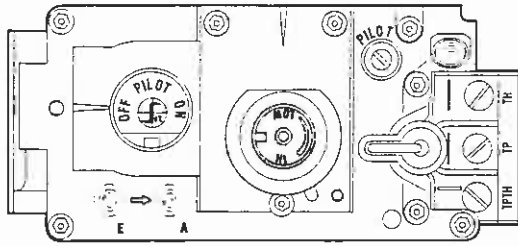

**Note:** Knob cannot be turned from "PILOT" to "OFF" unless the knob is pushed in slightly. Do not force.

**Turn Control Knob to "OFF" Position**

**Figure 23**

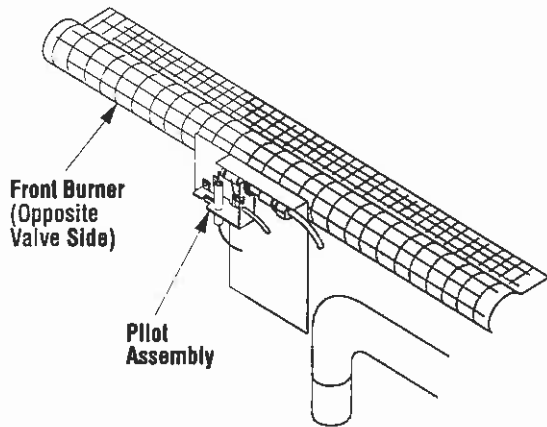

**Pilot Location**

**Figure 24**

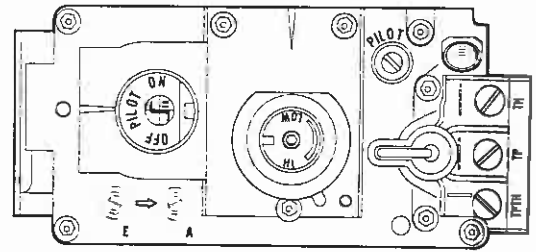

**Turn Control Knob to "PILOT" Position**

**Figure 25**

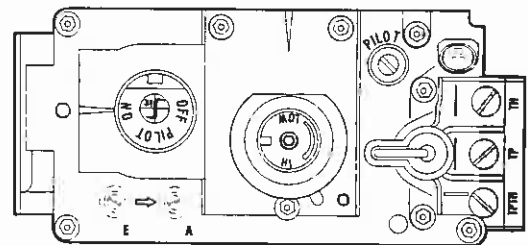

**Turn Control Knob to "ON" Position**

**Figure 26**



### CFST REPLACEMENT PARTS LIST

No.	Description	CFST-CMN		CFST-CMP	
		Part No.	Qty.	Part No.	Qty.
1.	Gas Fireplace Assembly	123071	1	123072	1
2.	Bar, Louver (Black)	104951	8	104951	8
3.	Hood (Black), Clean Face	108971	2	108971	2
4.	Screw	000861	6	000861	6
5.	Replacement Glass Panel with Gasket	104852	2	104852	2
6.	Door Switch	094468	1	094468	1
7.	Gas Valve with Burner Assembly	123111	1	123112	1
8.	Burner Assembly	123151	1	123151	1
9.	Log Set (Split)	-	-	-	-
a.	Bottom, Front	903601	1	903601	1
b.	Bottom, Rear	903602	1	903602	1
c.	Log, Center	903603	1	903603	1
d.	Twig, Left	903604	1	903604	1
e.	Top Twig, Center	903605	1	903605	1
f.	Top Twig, Right	903606	1	903606	1
g.	Log, Top, Vertical	903607	1	903607	1
10.	Bag of Rockwool/Ember Coals	125011	1	125011	1
11.	Refractory Liner	903216	2	903216	2

### CFST GAS CONTROLS — MILLIVOLT

No.	Description	CFST-CMN		CFST-CMP	
		Part No.	Qty.	Part No.	Qty.
20.	Gas Valve - SIT	901916	1	901917	1
21.	Piezo Igniter	111061	1	111061	1
22.	Orifice, Main Burners	124291	2	124292	2
23.	Pilot Assembly (ODS)	901914	1	901915	1

# REPLACEMENT PARTS – CFST

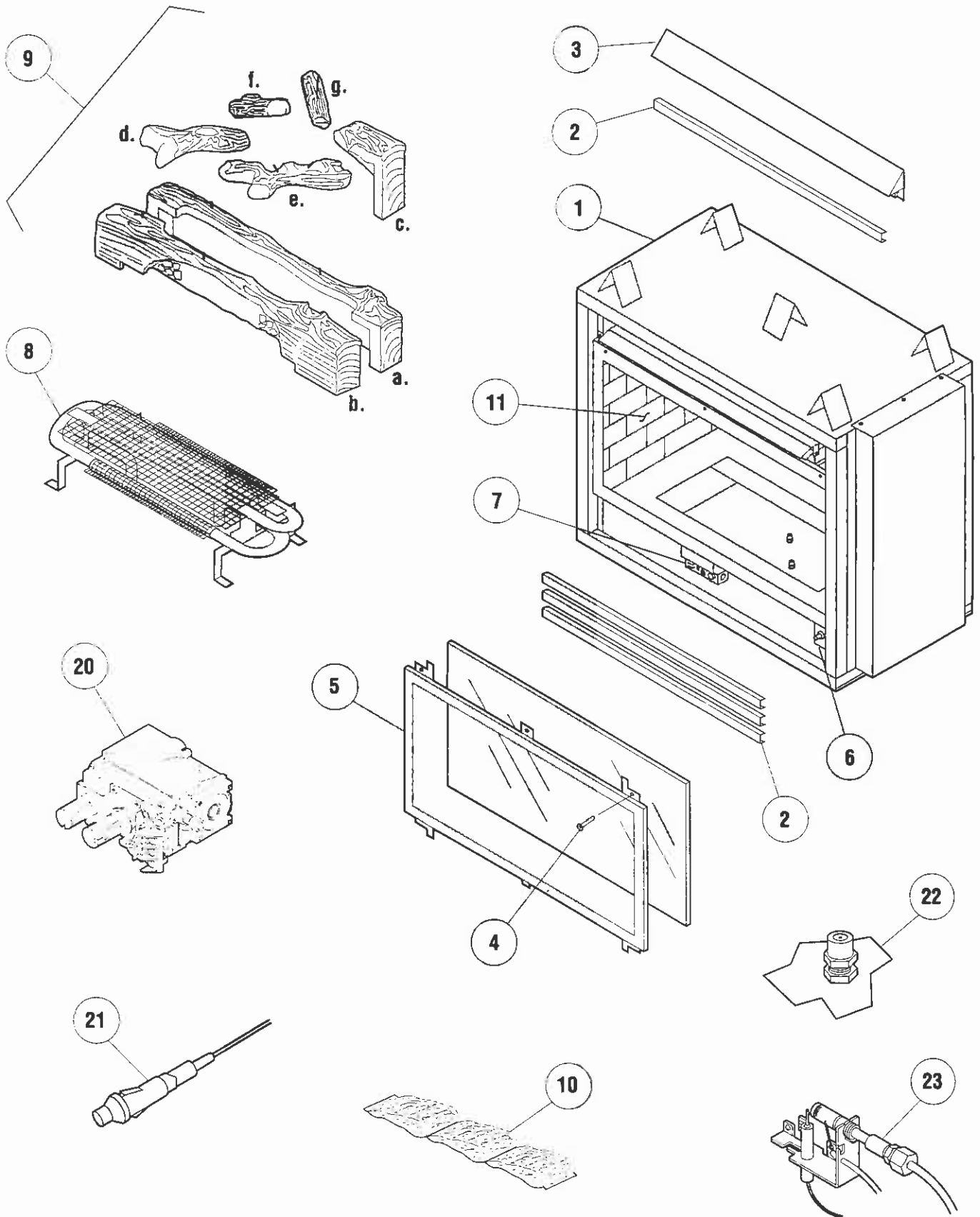

NOTE: DIAGRAMS & ILLUSTRATION NOT TO SCALE.

### CFPF REPLACEMENT PARTS LIST

No.	Description	CFPF-CMN		CFPF-CMP	
		Part No.	Qty.	Part No.	Qty.
1.	Gas Fireplace Assembly	123073	1	123074	1
2.	Bar, Louver (Black) - Main Panel	104951	8	104951	8
3.	Bar, Louver (Black) - End Panel	104955	4	104955	4
4.	Hood (Black), Clean Face - Main Panel	108971	2	108971	2
5.	Hood (Black), Clean Face - End Panel	124761	1	124761	1
6.	Screw	000861	8	000861	8
7.	Replacement Glass Panel with Gasket - Main Panel	104852	2	104852	2
8.	Replacement Glass Panel with Gasket - End Panel	104853	1	104853	1
9.	Door Switch	094468	1	094468	1
10.	Gas Valve with Burner Assembly	123111	1	123112	1
11.	Burner Assembly	123151	1	123151	1
12.	Log Set (Split)	-	-	-	-
a.	Bottom, Front	903601	1	903601	1
b.	Bottom, Rear	903602	1	903602	1
c.	Log, Center	903603	1	903603	1
d.	Twig, Left	903604	1	903604	1
e.	Top Twig, Center	903605	1	903605	1
f.	Top Twig, Right	903606	1	903606	1
g.	Log, Top, Vertical	903607	1	903607	1
13.	Bag of Rockwool/Ember Coals	125011	1	125011	1
14.	Refractory Liner	903216	1	903216	1

### CFPF GAS CONTROLS — MILLIVOLT

No.	Description	CFPF-CMN		CFPF-CMP	
		Part No.	Qty.	Part No.	Qty.
20.	Gas Valve - SIT	901916	1	901917	1
21.	Piezo Igniter	111061	1	111061	1
22.	Orifice, Main Burners	124291	2	124292	2
23.	Pilot Assembly (ODS)	901914	1	901915	1

# REPLACEMENT PARTS - CFPF

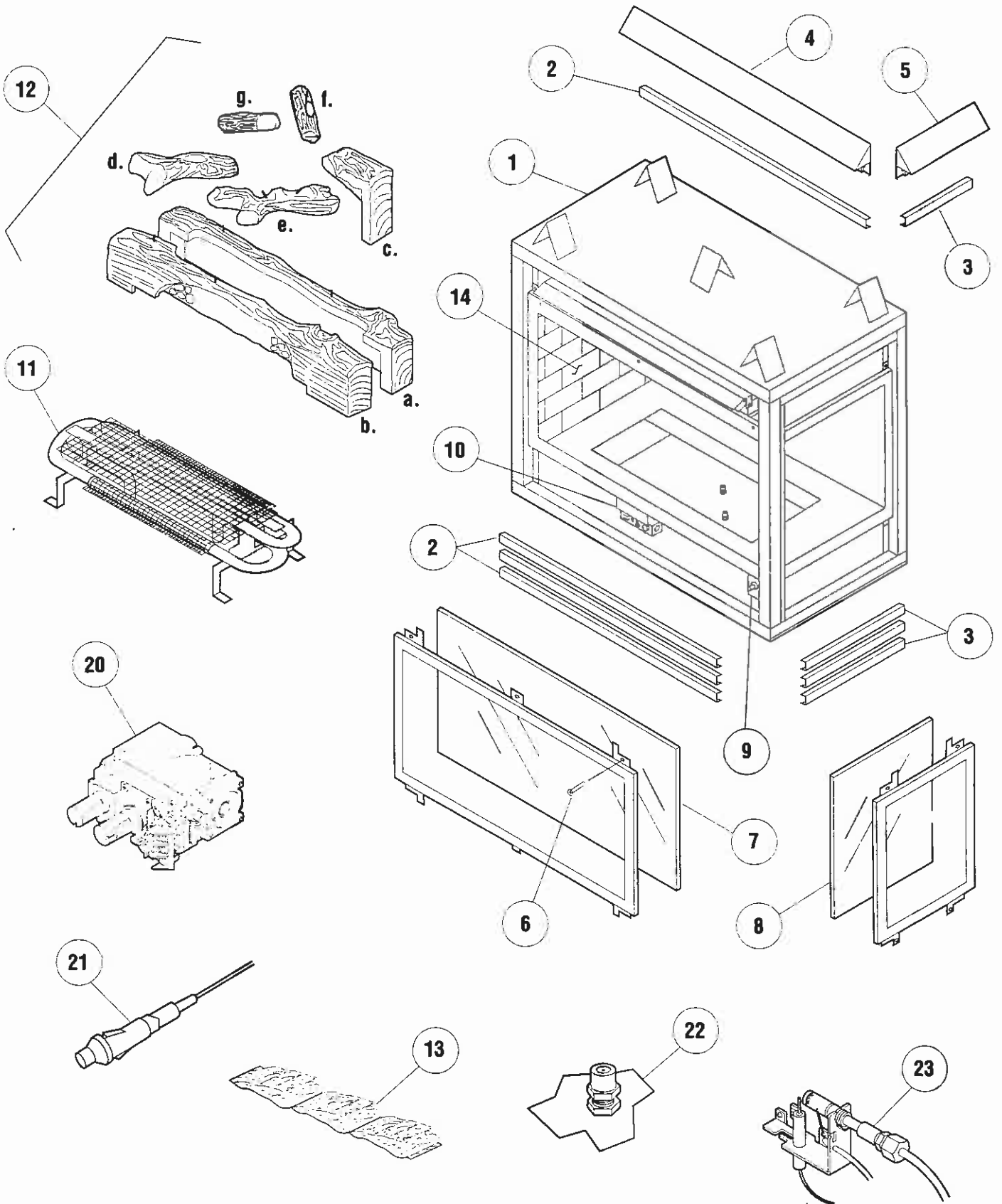

NOTE: DIAGRAMS & ILLUSTRATION NOT TO SCALE.

## TROUBLESHOOTING GUIDE FOR UNVENTED GAS PRODUCTS

OBSERVED PROBLEM	POSSIBLE CAUSE	REMEDY
1. When igniter button is pressed, there is no spark at ODS/pilot.	A. Igniter electrode positioned wrong.	Replace igniter.
	B. Igniter electrode broken.	Replace igniter.
	C. Igniter electrode not connected to igniter cable.	Reconnect igniter cable.
	D. Igniter cable pinched or wet.	Free igniter cable if pinched by any metal or tubing. Keep igniter cable dry.
	E. Piezo igniter nut is loose.	Tighten nut.
	F. Broken igniter cable.	Replace igniter cable.
	G. Bad piezo igniter.	Replace piezo igniter.
2. Heater produces unwanted odors.	A. Heater burning vapors from paint, hair spray, glues, etc.	Ventilate room. Stop using odor-causing products while fireplace is running.
	B. Gas leak. See Warning statement on the front page.	Locate and correct all leaks.
3. Heater shuts off in use (ODS operates).	A. Not enough fresh air is available.	Open window and/or door for ventilation.
	B. Low line pressure.	Contact local gas company.
	C. ODS/pilot is partially clogged.	Clean ODS/pilot.
4. Gas odor even when control knob is in "OFF" position.	A. Gas leak. See Warning statement on the front page.	Locate and correct all leaks (see Checking Gas Connections, page 8).
	B. Control valve defective.	Replace control valve.
5. When igniter button is pressed, there is spark at ODS/pilot, but no ignition.	A. Gas supply turned off or manual shut-off valve closed.	Turn on gas supply or open manual shut-off valve.
	B. Control knob not in "PILOT" position.	Turn control knob to pilot position.
	C. Control knob not pressed in while in "PILOT" position.	Press in control knob while in pilot position.
	D. Air in gas lines when installed.	Continue holding down control knob. Repeat igniting operation until air is removed.
	E. ODS/pilot is clogged.	Replace ODS/pilot assembly or get it serviced.
	F. Gas regulator setting is not correct.	Replace gas regulator.
6. ODS/pilot lights, but flame goes out when control knob is released.	A. Control knob not fully pressed in.	Press in control knob fully.
	B. Control knob not pressed in long enough.	After ODS/pilot lights, keep control knob pressed in 30 seconds.
	C. Manual shut-off valve not fully open.	Fully open manual shut-off valve.
	D. Thermocouple connection loose at control valve.	Hand tighten until snug, then tighten ¼ turn more.
	E. Pilot flame not touching thermocouple, which allows thermocouple to cool, causing pilot flame to go out. This problem could be caused by one or both of the following: 1). Low gas pressure 2). Dirty or partially clogged ODS/pilot	1). Contact local gas company. 2). Replace ODS/pilot assembly or get pilot serviced.
	F. Thermocouple damaged.	Replace thermocouple.
	G. Control valve damaged.	Replace control valve.
7. Burner does not light after ODS/pilot is lit.	A. Burner orifice is clogged.	Clean burner or replace burner orifice.
	B. Burner orifice diameter is too small.	Replace burner orifice.
	C. Inlet gas pressure is too low.	Contact local gas company.
8. Delayed ignition of burner.	A. Manifold pressure is too low.	Contact local gas company.
	B. Burner orifice is clogged.	Clean burner or replace burner orifice.
9. Burner backfiring during combustion.	A. Burner orifice is clogged or damaged.	Clean burner or replace burner orifice.
	B. Burner damaged.	Replace burner.
	C. Gas regulator defective.	Replace gas regulator.
10. Slight smoke or odor during initial operation.	A. Vapors from paint or curing process of logs.	Problem will stop after a few hours of operation. SFC recommends running the heater with excess ventilation for the first few hours.
11. Heater produces a whistling noise when burner is lit.	A. Turning control knob to "HI" position when burner is cold.	Turn control knob to "LO" position and let warm up for a minute.
	B. Air in gas line.	Operate burner until air is removed from line. Have gas line checked by local gas company.
	C. Dirty or partially clogged burner orifice.	Clean burner or replace burner orifice.





## Catalytic Gas Fireplace Manufacturer's Limited Warranty 10 Years

### THE WARRANTY

The manufacturer warrants the components of this Catalytic Gas Fireplace manufactured by SFC, INC. (hereinafter, SFC) to be free from defects in materials and workmanship at the time of manufacture.

### REMEDY AND EXCLUSIONS

The coverage of this Warranty is limited to all components of the Catalytic Gas Fireplace manufactured by SFC. SFC warrants the components of this factory-built system manufactured by SFC to be free from defects in material and workmanship at the time of manufacture.

- 1) During the first five years of this warranty, SFC will, at its option and except for the components listed in subparagraphs (a) through (e) below provide replacement or repair components of the factory-built gas insert manufactured by SFC at no charge, and will also pay for reasonable labor costs incurred in replacing or repairing such components. If repair or replacement is not commercially practicable, SFC will, at its option, refund the purchase price of the gas insert and chimney components and accessories. With respect to the components listed below, the remedies of this paragraph (1) are available only for the period of time indicated. Thereafter, however, until the expiration of 10 years from the date of installation, SFC will provide replacement parts at no charge but will not pay any labor costs. All replacement parts will be shipped F.O.B. factory.
  - (a) Gas logs, ember coals, brass-tone finishes, paint and fiber ceramic simulated brick side panels are not warranted with the exception of defects in material or workmanship.
  - (b) Catalytic Gas Room Heater electrical components, such as fan motors and blowers, electrical cord and electrical switches – one year from the date of installation.
  - (c) Gas components, such as gas valves, pilot assembly, igniter, micro door switch and CO Sensor kit – one year from the date of installation.
  - (d) Tempered glass – one year from the date of installation.
  - (e) Catalyst assembly – 2 years parts and labor, 3-5th. year, parts only from the date of installation.

This warranty covers only parts and labor as provided above. In no case shall SFC be responsible for materials, components, or construction which are not manufactured or supplied by SFC, or for the labor necessary to install, repair or remove such materials, components or construction.

### QUALIFICATIONS TO THE WARRANTY

The Catalytic Gas Room Heater Warranty outlined above is further subject to the following qualifications:

- (1) The Catalytic Gas Room Heater must be installed in accordance with SFC installation instructions and local building codes. The Warranty on this Catalytic Gas Room Heater covers only the component parts manufactured by SFC. The use of components manufactured by others with this Catalytic Gas Room Heater (except for a listed venting system as prescribed in the installation instructions) could create serious safety hazards, may result in the denial of certification by recognized national safety agencies, and could be in violation of local building codes. This Warranty does not cover any damages occurring from the use of any components not manufactured or supplied by SFC.
- (2) The Catalytic Gas Room Heater must be subjected to normal use. The gas inserts are designed to burn either natural or propane gas only. Burning conventional fireplace fuels such as wood, coal, or any other solid fuel will cause damage to the gas insert, will produce excessive temperatures and will result in a fire hazard.

### LIMITATION ON LIABILITY

It is expressly agreed and understood that SFC's sole obligation and purchaser's exclusive remedy under this warranty, under any other warranty, expressed or implied, or in contract, tort or otherwise, shall be limited to replacement, repair, or refund, as specified above.

In no event shall SFC be responsible for any incidental or consequential damages caused by defects in its products, whether such damage occurs or is discovered before or after replacement or repair, and whether or not such damage is caused by SFC's negligence. Some states do not allow the exclusion or limitation of incidental or consequential damages, so the above limitation or exclusion may not apply to you. The duration of any implied warranty with respect to this SFC gas insert is limited to the duration of the foregoing warranty. Some states do not allow limitations on how long an implied warranty lasts, so the above may not apply to you.

### INVESTIGATION OF CLAIMS AGAINST WARRANTY

SFC reserves the right to investigate any and all claims against this Warranty and to decide upon method of settlement.

### SUPERIOR FIREPLACE COMPANY NOT RESPONSIBLE FOR WORK DONE WITHOUT WRITTEN CONSENT

SFC shall in no event be responsible for any warranty work done without first obtaining SFC's written consent.

### DEALERS HAVE NO AUTHORITY TO ALTER THIS WARRANTY

SFC employees and dealers have no authority to make any warranties nor to authorize any remedies in addition to or inconsistent with those stated above.

### HOW TO REGISTER A CLAIM AGAINST WARRANTY

In order for any claim under this Warranty to be valid, SFC must be notified of the claimed defect in writing to SFC, attention Customer Service Department, 1110 West Taft Avenue, Orange, California 92865, as soon as reasonably possible after the defect is discovered. Claims against this Warranty in writing should include the date of installation, and a description of the defect.

### OTHER RIGHTS

This Warranty gives you specific legal rights, and you may also have other rights which vary from state to state.

SFC reserves the right to make changes at any time, without notice, in design, materials, specifications, prices and also to discontinue colors, styles and products. Consult your local distributor for fireplace code information.