

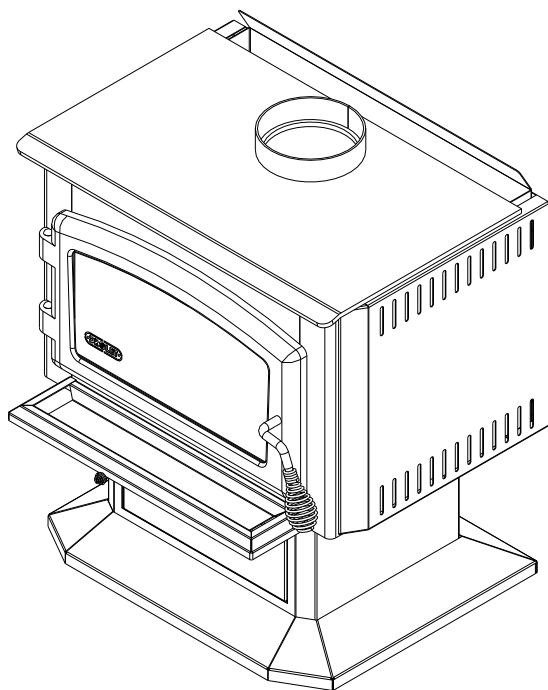

OWNER`S MANUAL

ELDORADO, ADIRONDACK, JURASSIEN, CELTIC AND SAVANNAH



US ENVIRONMENTAL PROTECTION
AGENCY PHASE II CERTIFIED
WOODSTOVES

Verified and tested following
ULC S627 and UL 1482 Standards by:



Manufactured by: **STOVE BUILDER INTERNATIONAL INC.**
250, de Copenhague, Saint-Augustin-de-Desmaures (Québec) G3A 2H3
Tel: (418) 878-3040
Fax: (418) 878-3001
www.drolet.ca

45061A
27-08-2010

INTRODUCTION

SBI INC., one of the most important wood stove and fireplace manufacturers in Canada, congratulates you on your purchase and wishes to help you get maximum satisfaction from your wood stove. In the pages that follow, we will give you advice on wood heating and controlled combustion as well as technical specifications regarding installation, operation and maintenance of the model you have chosen.

The instructions pertaining to the installation of your wood stove comply with ULC-S627 and UL-1482 standards.

Read this entire manual before you install and use your new stove. If this stove is not properly installed, a house fire may result. To reduce the risk of fire, follow the installation instructions. Failure to follow instructions may result in property damage, bodily injury, or even death.

Consult your municipal building department or fire officials about restrictions and installations requirements in your area and the need to obtain a permit.

Keep this instructions manual for future references.

CAUTIONS:

- HOT WHILE IN OPERATION. KEEP CHILDREN, CLOTHING AND FURNITURE AWAY. CONTACT MAY CAUSE SKIN BURNS.
- DO NOT USE CHEMICALS OR FLUIDS TO IGNITE THE FIRE.
- DO NOT LEAVE THE STOVE UNATTENDED WHEN THE DOOR IS SLIGHTLY OPENED.
- DO NOT BURN WASTES, FLAMMABLE FLUIDS SUCH AS GASOLINE, NAPHTHA OR MOTOR OIL.
- DO NOT CONNECT TO ANY AIR DISTRIBUTION DUCT OR SYSTEM.
- ALWAYS CLOSE THE DOOR AFTER THE IGNITION.

REGISTER YOUR WARRANTY ONLINE

To receive full warranty coverage, you will need to show evidence of the date you purchased your stove. Keep your sales invoice. We also recommend that you register your warranty online at

www.drolet.ca

Registering your warranty online will help us track rapidly the information we need on your stove.

TABLE OF CONTENTS

INTRODUCTION.....	2
TECHNICAL SPECIFICATIONS	4
TIPS ON WOOD HEATING	6
ASSEMBLY	7
PEDESTAL AND PANELS.....	7
LEGS AND ASH PAN.....	8
DOOR ADJUSTMENT.....	9
ASH LIP INSTALLATION FOR JURASSIEN MODEL.....	10
THE BENEFITS OF INSTALLING A BLOWER.....	11
INSTALLATION.....	12
POSITIONING THE STOVE	12
CLEARANCES TO COMBUSTIBLES AND FLOOR PROTECTOR	13
FLOOR PROTECTOR.....	15
<i>REDUCED CLEARANCES USING SHIELDING</i>	16
CHIMNEY.....	20
CHIMNEY CONNECTOR (STOVE PIPE)	21
TYPICAL INSTALLATIONS	22
OUTSIDE COMBUSTION AIR	26
WOOD STOVE UTILISATION	27
AVERAGE ENERGY YIELD OF ONE AIR DRIED CORD OF CUT WOOD	27
TESTING YOUR WOOD.....	28
THE FIRST FIRES.....	28
IGNITION	28
HEATING.....	29
RELOADING.....	30
CREOSOTE FORMATION AND NEED FOR REMOVAL	30
ASH DISPOSAL	31
MAINTENANCE	32
GLASS.....	32
GASKETING	32
PAINT	32
DROLET LIMITED LIFETIME WARRANTY.....	33

TECHNICAL SPECIFICATIONS

Combustible:	Wood
Recommended Surface	500 to 1 500 ft ² (47 to 140 m ²)
Heating Capacity*:	E.P.A.: 44 000 BTU/h (12.8kW)
Seasoned cord wood:	55 000 BTU/h (16.2 kW)
Efficiency**:	85%
Emissions:	6.28 g/h
Colour:	Metallic Black
Flue Pipe Diameter:	6" (152 mm)
Chimney type:	2 100 °F (650 °C)
Minimum Chimney Height:	12' (3,66 m)
Maximum Log Length:	18" (460 mm)
Dimensions	
Overall:	W x D x H
Eldorado, Celtic:	25 x 21 x 26" (635 x 533 x 660 mm)
Adirondack:	25 ½ x 21 x 28 3/8" (648 x 533 x 721 mm)
Savannah:	25 x 25 ¼ x 29 3/8" (635 x 541 x 746 mm)
Jurassien:	31 x 19 ¼ x 29 5/16" (787 x 489 x 745mm)
Combustion Chamber:	W x D
Width x Depth:	20 ¼ x 11 ¼ " (514 x 286 mm)
Volume:	1,47 pi ³ (0,04 m3)
Door Opening:	W x H
All Models:	7 5/8" x 18 1/4" (200 x 464 mm)
Pyroceram Glass Door:	W x H
Adirondack, Celtic, Savannah, Eldorado:	8 ¾" x 16 ½ " (222 x 419 mm)
Jurassien:	10" x 18 ¼ " (254 x 464 mm)
Weight:	Eldorado: 255 lbs (116 Kg)
Adirondack, Celtic, Savannah:	280 lbs (127 Kg)
Jurassien:	415 lbs (188 Kg)

OPTIONS	PART NUMBER
Ultra-quiet blower with variable speed control	All Models: AC02050
Thermodisc 90-120 °F (32-49 °C).	All Models: AC05530
Outside air intake kit	All Models: AC02080

***Why is the BTU indicated on the EPA label different than the one advertised?**

You will notice a difference between the BTU output indicated on the unit's white EPA label affixed to the glass and the BTU advertised on our web site and/or product literature. The maximum BTU output we advertise for this unit is what will be obtained with a full load of seasoned cordwood inserted inside the firebox. The EPA output, on the other hand, is what has been obtained during emissions testing. The EPA test procedure requires that a special type of wood be used and positioned inside the firebox in a manner that does not represent the way the firebox volume would normally be utilized using seasoned cordwood. The EPA test load is typically much smaller. Hence, the BTU as per the EPA label is reduced. The BTU output that should be considered by a normal user is the one we advertise for seasoned cordwood.

****What is the efficiency of this model?**

First, it is important to mention that the efficiency calculation is not mandatory in North America. Manufacturers who have tested their appliances to the EPA Standard must report a "default" efficiency on the little white EPA tag that must be affixed to the stove. This is why you will normally see a 63% efficiency rating on that EPA tag. The real efficiency of EPA-certified units, however, is normally between 70% and 80%. It is possible for manufacturers to test their appliances for efficiency. Manufacturers that report an efficiency rating higher than 63% have probably had their appliances tested through an independent laboratory. Although there exists more than one recognized efficiency calculation method, the one normally used by North American manufacturers is the Canadian CSAB415.1 method. Our appliances have all had their efficiency tested per that method. You will notice that the vast majority of our appliances have an efficiency rating between 70% and 80%, as indicated on the yellow tag affixed to the appliance's glass. We are of the opinion that EPA-certified appliances with an efficiency rating within that range will provide an equivalent performance. In other words, when you are considering the purchase of one of our EPA-certified appliances and you hesitate between two models, their efficiency rating should not constitute your number one criteria. First, make sure that you select an EPA-certified appliance. Then, concentrate on the features that matter the most to you, such as the look, the size of the firebox, the warranty, etc. Please note that the use of a blower is always recommended to improve air circulation. This will also optimize your efficiency.

TIPS ON WOOD HEATING

Wood is a renewable energy. It is also a very clean heat source when used with appliances that are certified by the U.S. Environmental Protection Agency (EPA), a standard accepted in Canada as well.

EPA-certified wood stoves are different than conventional wood stoves. Burning with an EPA-certified wood stove may therefore require that you modify some of your heating habits. To get the most satisfaction out of your new wood-heating system, please make sure you go through the following check list.

- ✓ The chimney is the engine that drives the wood-heating system. Use a chimney that is UL-listed, with an inner diameter to match the stove's outlet collar (6" for all Drolet wood stoves);
- ✓ Try to run the chimney inside the building for as much length as you can. A tall and warm chimney will produce a good draft;
- ✓ Try to install your chimney straight up and avoid 90 degree turns in the flue pipe and offsets in the chimney;
- ✓ Make sure that the chimney is tall enough and its top is clear of obstacles so it can produce a stable draft;
- ✓ Use a chimney thermometer installed at a distance of approximately 18 inches on the flue pipe above the stove. Flue gases should reach at least 350 °F before you close the stove's primary air intake completely. Operate your unit within the comfort zone indicated on the thermometer;
- ✓ To reduce the risk of smoke spillage into the room upon reloading your stove, leave the primary air intake completely open for a few minutes. This will heat up the chimney and build up draft before you open the stove door;
- ✓ Maximize hot air circulation! Our wood stoves are designed to easily receive a variable speed blower that will improve heat distribution in front of the stove;
- ✓ Remember that wood stoves produce radiant heat. Since heat rises, the use of floor traps will greatly improve the heat transfer to rooms upstairs;
- ✓ Use a mobile home approved stove if you are going to install your wood-heating system in a mobile home. A fresh air kit must be connected to the stove. Never install your wood stove in a bedroom;
- ✓ Burn only dry cordwood;
- ✓ Make sure you have a good bed of red coals before you load your stove with logs exceeding 3 inches in diameter;
- ✓ Read and keep you owner's manual. It will provide you with tips on how to run a successful wood-heating system.

ASSEMBLY

PEDESTAL AND PANELS

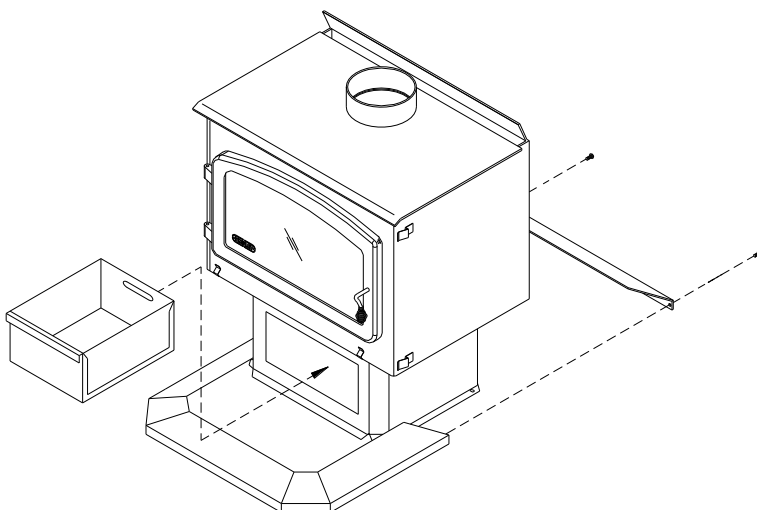

Pedestal Base Installation:

1. Slide the front part of the pedestal base around the pedestal and fix the rear part with the two supplied screws.
2. Slide the ash pan in position.

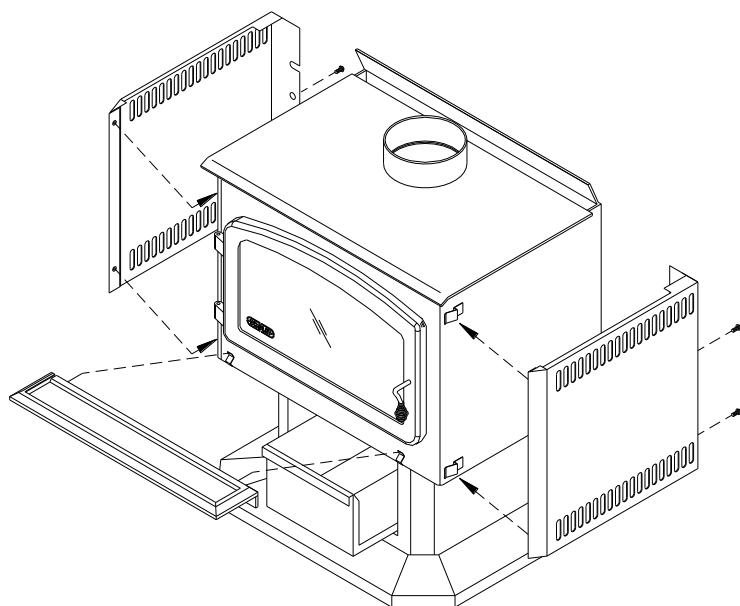

Side Panels and Ash Lip Installation:

1. Start by fixing the front part of the decorative side in the two clips welded on the sides of the fire box.
2. Then, fix the back of the decorative side with two screws and washers supplied. Line up the decorative side parallel to the side of the appliance.
3. Clip the ash lip into position, centred just below the door.

LEGS AND ASH PAN

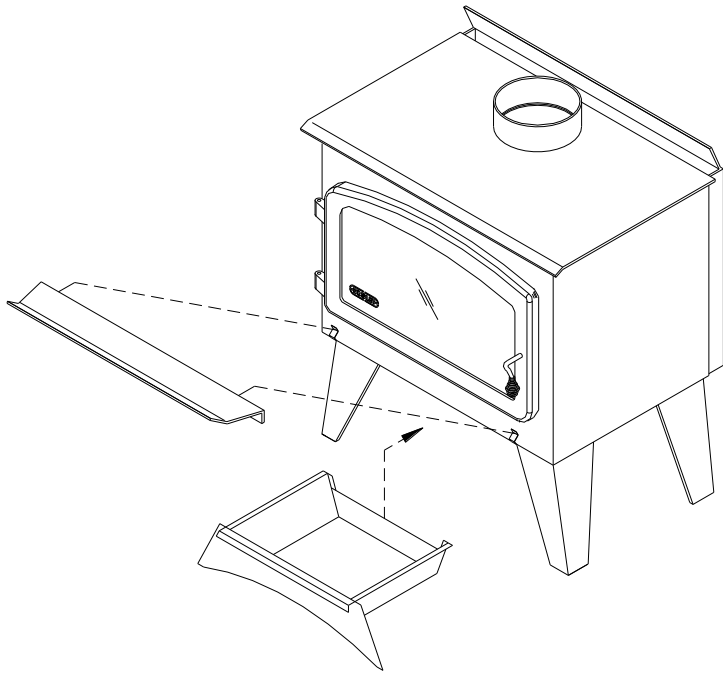

Ash Lip Installation:

1. Just clip the ash lip into position, centred just below the door.
2. Slide the ash pan in position.

DOOR ADJUSTMENT

In order for your stove to operate properly, the door should be adjusted periodically to provide an air tight fit. To adjust:

- Remove the lock pin (spring pin) by pulling and turning it using pliers ("wise grip")
- Turn the handle counter clock wise one turn to increase pressure
- Re-install the lock pin (spring pin) with a small hammer

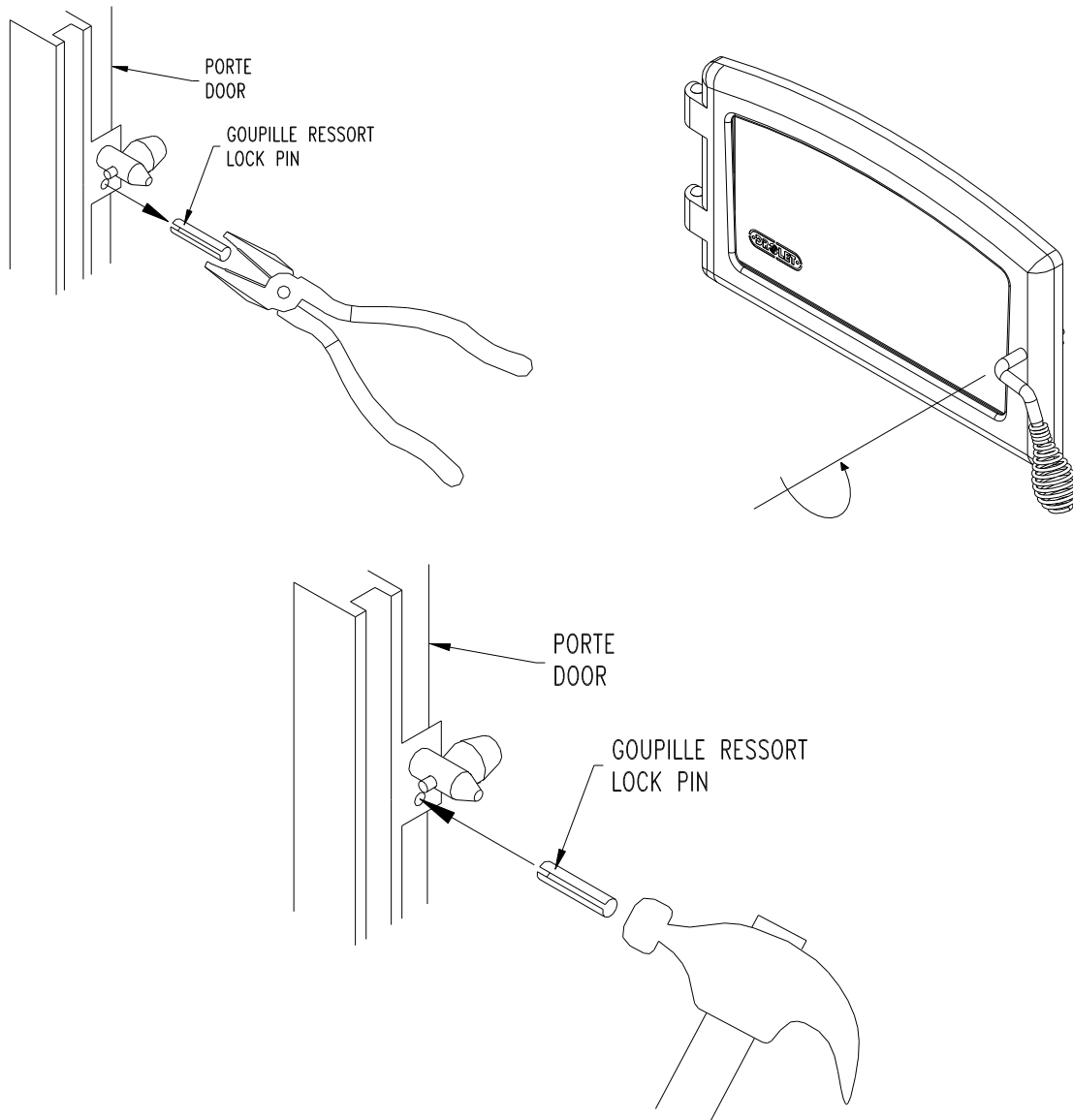
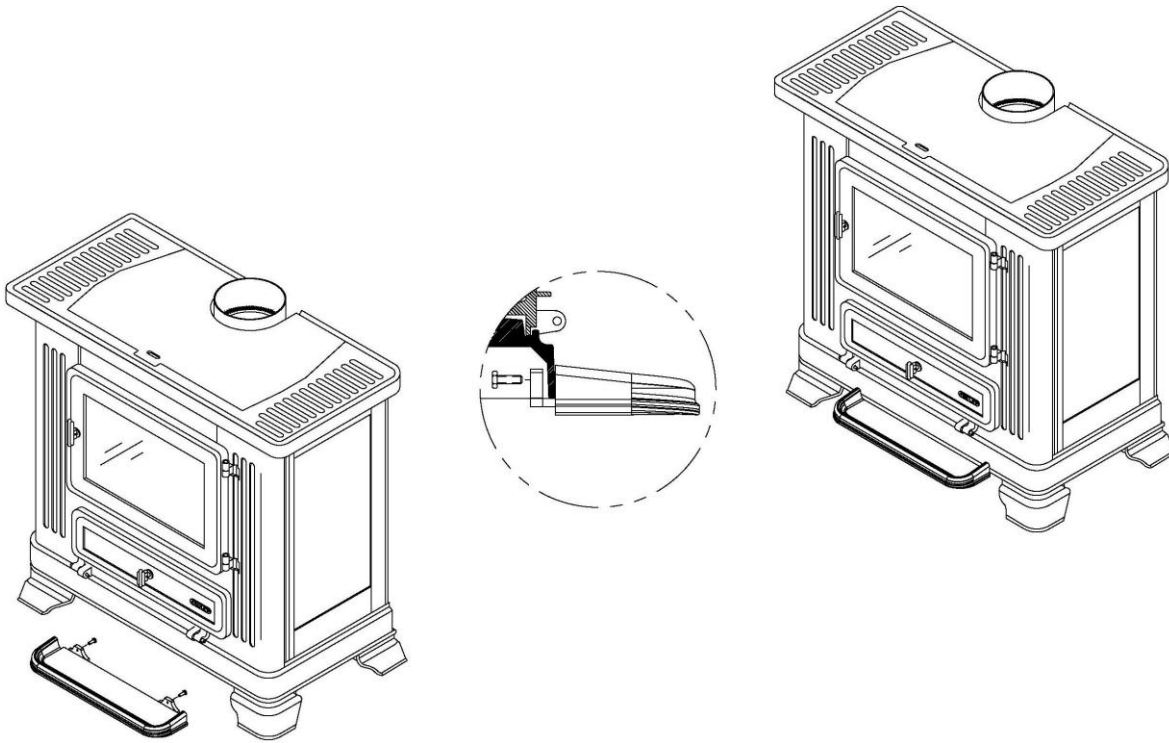

Figure 1: Door Adjustment

ASH LIP INSTALLATION FOR JURASSIEN MODEL

Your Jurassien can be equipped with an ash lip.

Place it as shown on detail below and secure it in place using the two bolts supplied with the owner's manual.



THE BENEFITS OF INSTALLING A BLOWER

A blower can be installed at the back of your DROLET stove. This option is necessary if you wish to redistribute into a room the heat trapped at the back of your stove. By forcing hot air toward the front, the blower enables you to extend the radiation power of your stove.

You can purchase this option through your DROLET dealer. Make sure to specify this part number: #AC02050. You can also install a thermodisc to enable the blower to start or stop automatically when the stove is hot or too cold. The thermodisc part number is AC05530. Installation instructions are supplied with the blower and the thermodisc.

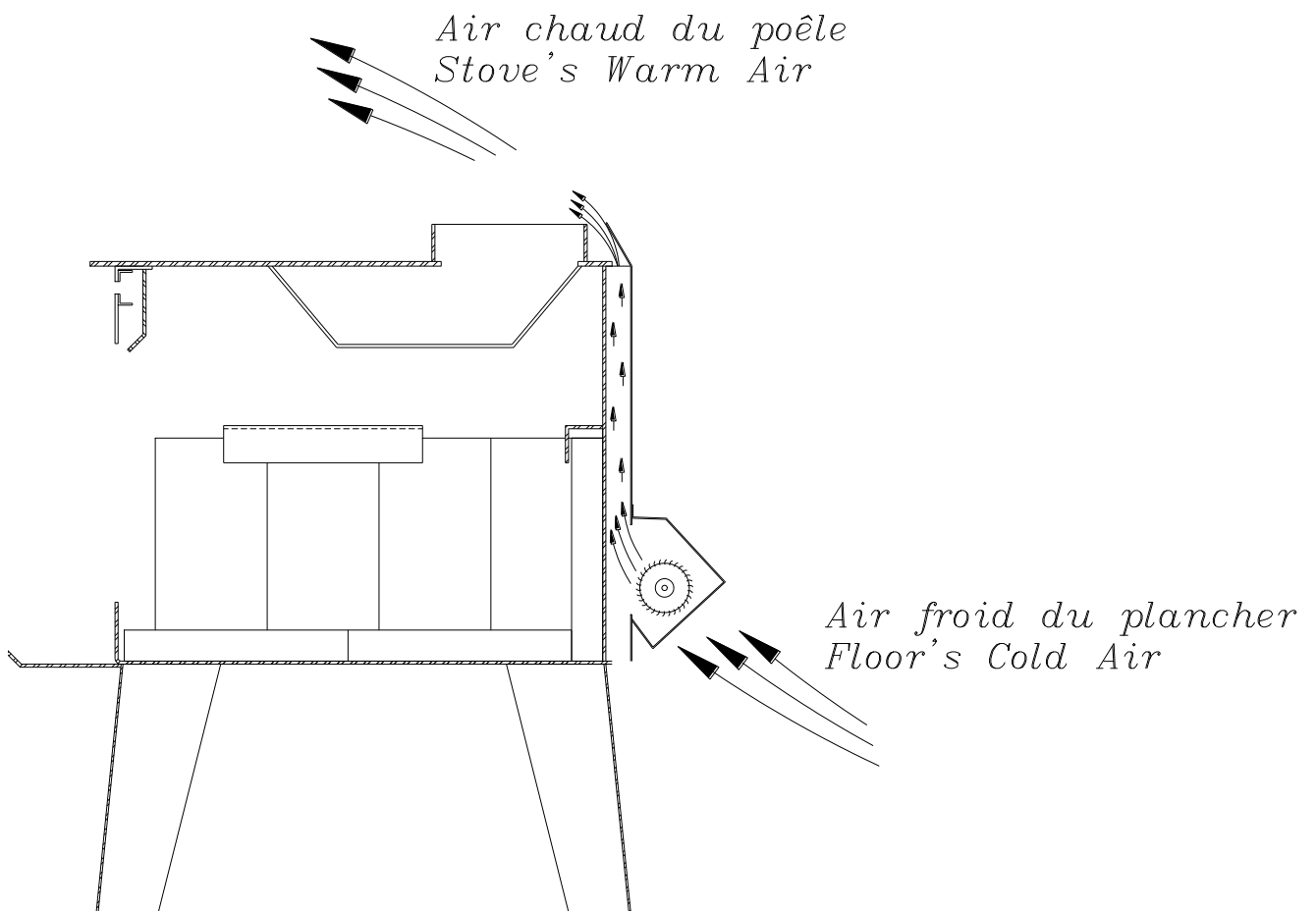

INSTALLATION

SAFETY NOTICE

- IF THIS STOVE IS NOT PROPERLY INSTALLED, A HOUSE FIRE MAY RESULT. TO REDUCE THE RISK OF FIRE, FOLLOW THE INSTALLATION INSTRUCTIONS. FAILURE TO FOLLOW INSTRUCTIONS MAY RESULT IN PROPERTY DAMAGE, BODILY INJURY, OR EVEN DEATH.
- CONSULT YOUR MUNICIPAL BUILDING DEPARTMENT OR FIRE OFFICIALS ABOUT RESTRICTIONS AND INSTALLATIONS REQUIREMENTS IN YOUR AREA.
- USE SMOKE DETECTORS IN THE ROOM WHERE YOUR STOVE IS INSTALLED.
- KEEP FURNITURE AND DRAPES WELL AWAY FROM THE STOVE.
- NEVER USE GASOLINE, GASOLINE-TYPE LANTERN FUEL, KEROSENE, CHARCOAL LIGHTER FLUID, OR SIMILAR LIQUIDS TO START OR "FRESHEN UP" A FIRE. KEEP ALL SUCH LIQUIDS WELL AWAY FROM THE STOVE.
- IN THE EVENT OF A CHIMNEY FIRE, PUSH THE AIR CONTROL FULL CLOSED TO DEPRIVE THE FIRE OF OXYGEN. CALL THE FIRE DEPARTMENT.
- DO NOT CONNECT TO ANY AIR DISTRIBUTION DUCT OR SYSTEM.
- A SOURCE OF FRESH AIR INTO THE ROOM OR SPACE HEATED SHALL BE PROVIDED WHEN REQUIRED.

POSITIONING THE STOVE

It is very important to position the wood stove as close as possible to the chimney, and in an area that will favour the most efficient heat distribution possible throughout the house. The stove must therefore be installed in the room where the most time is spent, and in the most spacious room possible. Recall that wood stoves produce radiating heat, the heat we feel when we are close to a wood stove. A wood stove also functions by convection, that is through the displacement of hot air accelerated upwards and its replacement with cooler air. If necessary, the hot air distribution from the stove may be facilitated by the installation of a blower.

The wood stove must not be hooked up to a hot air distribution system since an excessive accumulation of heat may occur.

A wood stove must never be installed in a hallway or near a staircase, since it may block the way in case of fire or fail to respect required clearances.

CLEARANCES TO COMBUSTIBLES AND FLOOR PROTECTOR

To install your appliance correctly, it is extremely important to respect all clearances to any combustibles as indicated on your stove's certification label.

Clearances to combustible materials

(see figure 2 to match each letter to a clearance)

	CLEARANCES (SINGLE WALL PIPE) CANADA & USA							
MODEL	A	B	C	D	E	F	K	L
Eldorado	15" (380 mm)	18" (460 mm)	12" (300 mm)	18.5" (470 mm)	27.5" (700 mm)	21" (535 mm)	48" (1220 mm)	84" (217 cm)
Adirondack	15" (380 mm)	12" (300 mm)	10" (250 mm)	18.5" (470 mm)	21.5" (545 mm)	19" (485 mm)	48" (1220 mm)	84" (217 cm)
Savannah	15" (380 mm)	18" (460 mm)	12" (300 mm)	18.5" (470 mm)	27.5" (700 mm)	21" (535 mm)	48" (1220 mm)	84" (217 cm)
Celtic	15" (380 mm)	12" (300 mm)	10" (250 mm)	18.5" (470 mm)	21.5" (545 mm)	19" (485 mm)	48" (1220 mm)	84" (217 cm)
Jurassien	14" (360 mm)	8" (205 mm)	10" (250 mm)	17.8" (450 mm)	20.5" (520 mm)	19.5" (495 mm)	48" (1220 mm)	84" (217 cm)

	CLEARANCES (DOUBLE WALL PIPE) CANADA & USA							
MODEL	A	B	C	D	E	F	K	L
Eldorado	6" (150 mm)	18" (460 mm)	12" (300 mm)	9.5" (240 mm)	27.5" (700 mm)	21" (535 mm)	48" (1220 mm)	84" (217 cm)
Adirondack	5" (130 mm)	12" (300 mm)	8" (200 mm)	8.5" (215 mm)	21.5" (545 mm)	17" (430 mm)	48" (1220 mm)	84" (217 cm)
Savannah	6" (150 mm)	18" (460 mm)	12" (300 mm)	9.5" (240 mm)	27.5" (700 mm)	21" (535 mm)	48" (1220 mm)	84" (217 cm)
Celtic	5" (130 mm)	12" (300 mm)	8" (200 mm)	8.5" (215 mm)	21.5" (545 mm)	17" (430 mm)	48" (1220 mm)	84" (217 cm)
Jurassien	7" (180 mm)	8" (205 mm)	6" (150 mm)	10.7" (270 mm)	20.5" (520 mm)	15.2" (385 mm)	48" (1220 mm)	84" (217 cm)

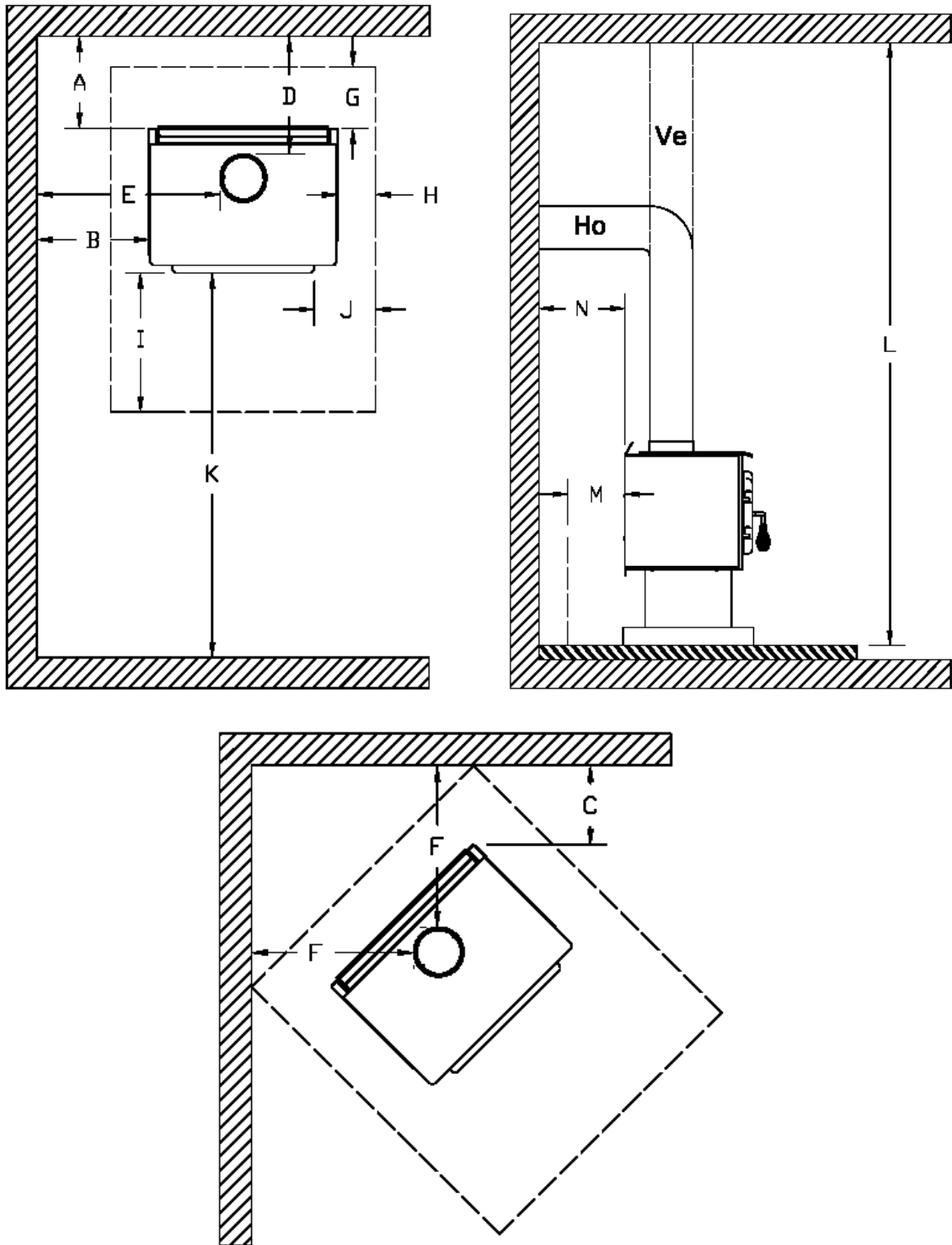

Figure 2: Clearances to combustibles and floor protector

FLOOR PROTECTOR

If the stove is to be installed on top of a combustible floor, it must be guarded by a non combustible material as shown on figure 2 (see the dotted line area).

	FLOOR PROTECTOR*	
	CANADA	USA
G	8" (205 mm) – Note 1	N/A (Canada only)
H	8" (205 mm)	N/A (Canada only)
I	18" (457 mm) From door opening	16" (406 mm) From door opening
J	N/A (USA only)	8" (205 mm)
M	8" (205 mm)	N/A (Canada only)
N	N/A (USA only)	Note 2

**Steel with a minimum thickness of 0.015" (0.38 mm) or ceramic tiles sealed together with grout. No protection is required if the unit is installed on a non-combustible floor (ex: concrete).*

Note 1: The floor protection at the back of the stove is limited to the stove's required clearance if such clearance is smaller than 8 inches (203 mm).

Note 2: Only required under the horizontal section of the connector. Must exceed each side of the connector by at least 2 inches (51 mm).

REDUCED CLEARANCES USING SHIELDING

You may decrease the clearances by installing heat radiation shields between the walls or the ceiling and the stove. These heat radiation shields must be installed permanently, and can include sheet metal, a rigid non-combustible sheet or a masonry wall.

Clearances of not less than 1" (25 mm) and not more than 3" (76 mm) between the bottom of the shield and the floor and not less than 3" (76 mm) between the top of the shield and the ceiling must be respected to allow vertical air circulation behind the shield. The shield must extend 20" (500 mm) above the stove top and 18" (450mm) to each side of the stove (see Graphic 1).

Following the installation of such a heat radiation shield, the clearances mentioned on the stove certification plate may be reduced as stated in the following table.

TYPE OF PROTECTION	Reducing Clearances With Shielding	
	Sides and Rear/Back	Top
Sheet metal, a minimum of 0,024" (0,61 mm) spaced out at least 1" (25 mm) by non-combustible spacers (see graphic 2).	67%	50%
Ceramic tiles, or an equivalent non-combustible material on fire-proof supports spaced out at least 1" (25 mm) by non-combustible spacers (see graphic 3).	50%	33%
Ceramic tiles, or an equivalent non-combustible material on fire-proof supports with a minimum of 0,024" (0,61 mm) sheet metal backing spaced out at least 1" (25 mm) by non-combustible spacers (see graphic 4)	67%	50%
Brick spaced out at least 1" (25 mm) by non-combustible spacers (see graphic 5)	50%	N/A
Brick with a minimum of 0,024" (0,61 mm) sheet metal backing spaced out at least 1" (25 mm) by non-combustible spacers (see graphic 6).	67%	N/A

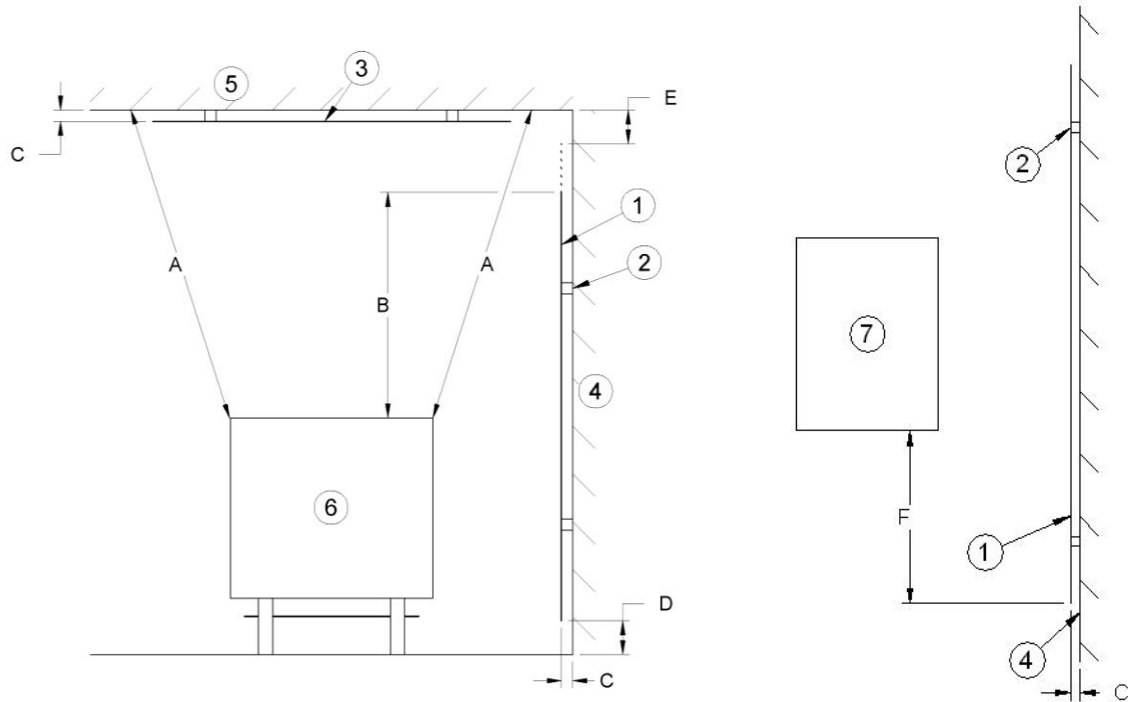

Graphic 1

A- Minimum clearance required between the appliance and an unshielded combustible ceiling.

B- 20 in. (500 mm) minimum;

C- 1 in. (25 mm) minimum;

D- Between 1 in. and 3 in. (25 mm and 75 mm);

E- 3 in. (75 mm) minimum;

F- 18 in. (457 mm) minimum.

1- Shielding;

2- Non-combustible spacers;

3- Ceiling protector;

4- Combustible wall;

5- Ceiling;

6- Appliance (side view);

7- Appliance (top view).

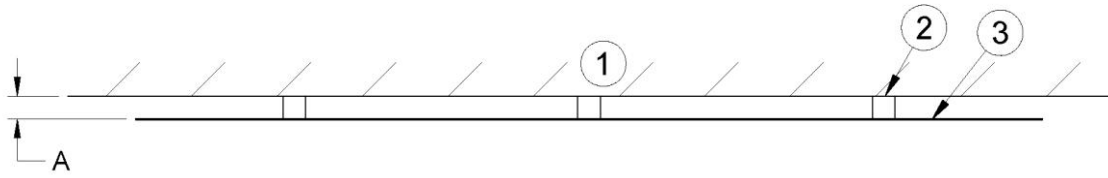

Graphic 2

A- 1 in.(25 mm) minimum;

- 1- Combustible wall;
- 2- Non-combustible spacers;
- 3- 0.024" (0.61 mm) sheet metal.

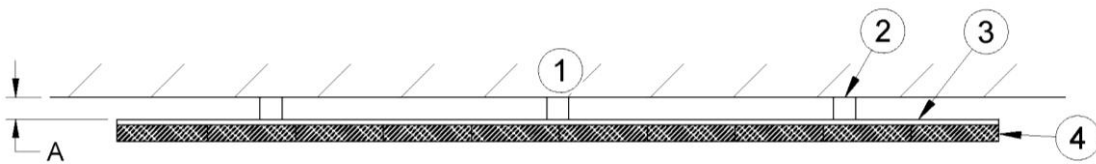

Graphic 3

A- 1 in. (25 mm) minimum;

- 1- Combustible wall;
- 2- Non-combustible spacers;
- 3- Non-combustible support;
- 4- Ceramic tile or non-combustible material.

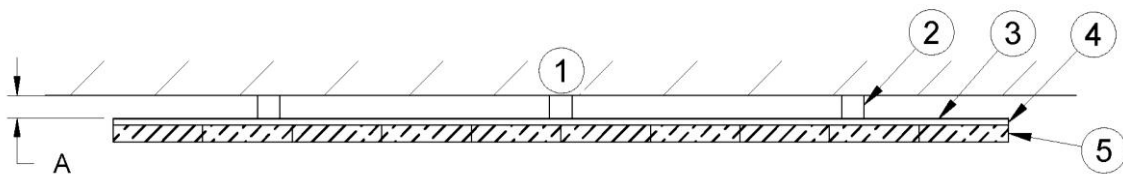

Graphic 4

A- 1 in. (25 mm) minimum;

- 1- Combustible wall;
- 2- Non-combustible spacer;
- 3- 0.024" (0.61 mm) thick sheet metal;
- 4- Non-combustible support;
- 5- Ceramic tile or non-combustible material.

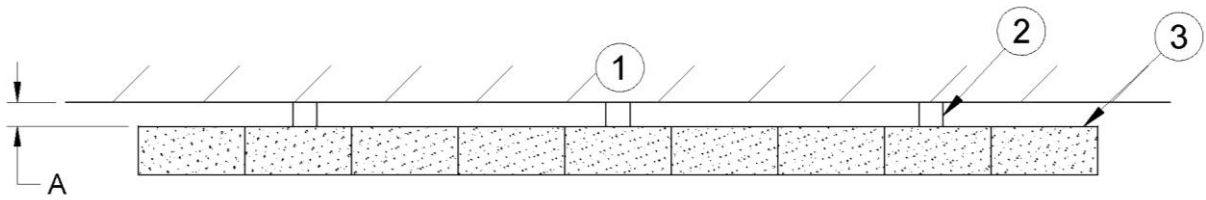

Graphic 5

A- 1 in. (25 mm) minimum;

- 1- Combustible wall;
- 2- Non-combustible spacers;
- 3- Brick.

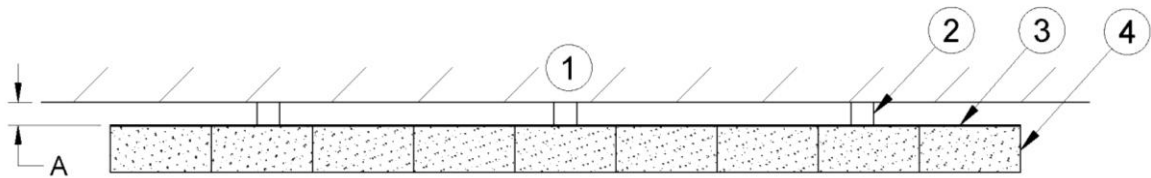

Graphique 6

A- 1 in. (25 mm) minimum;

- 1- Combustible wall;
- 2- Non-combustible spacers;
- 3- 0.024" (0.61 mm) thick sheet metal;
- 4- Brick.

CHIMNEY

Your wood stove may be hooked up with a factory built or masonry chimney. If you are using a factory built chimney, it must comply with UL 103 or ULC S629 standards; therefore it must be a Type HT (2100 °F). It is extremely important that it be installed according to the manufacturer's specifications.

If you are using a masonry chimney, it is important that it be built in compliance with the specifications of the National Building Code. It must be lined with fire clay bricks, metal or clay tiles sealed together with fire cement. (Round flues are the most efficient).

The interior diameter of the chimney flue must be identical to the stove's smoke exhaust. A flue which is too small may cause draught problems, while a large flue favours rapid cooling of the gas, and hence the build-up of creosote and the risk of chimney fires. Note that it is the chimney and not the stove which creates the draught effect; your stove's performance is directly dependent on an adequate draught from your chimney.

The following recommendations may be useful for the installation of your chimney:

- 1. Do not connect this unit to a chimney flue serving another appliance.**
- 2. It must rise above the roof at least 3' (0.9 m) from the uppermost point of contact.**
- 3. The chimney must exceed any part of the building or other obstruction within a 10' (3.04 m) distance by a height of 2' (0.6 m).**
- 4. Installation of an interior chimney is always preferable to an exterior chimney. Indeed, the interior chimney will, by definition, be hotter than an exterior chimney, being heated up by the ambient air in the house. Therefore the gas which circulates will cool more slowly, thus reducing the build-up of creosote and the risk of chimney fires.**
- 5. The draught caused by the tendency for hot air to rise will be increased with an interior chimney.**
- 6. Using a fire screen at the extremity of the chimney requires regular inspection in order to insure that it is not obstructed thus blocking the draught, and it should be cleaned when necessary.**

CHIMNEY CONNECTOR (STOVE PIPE)

Your chimney connector and chimney must have the same diameter as the stove outlet. If this is not the case, we recommend you contact your dealer in order to insure there will be no problem with the draught.

The stove pipe must be made of aluminized or cold roll steel with a minimum thickness of 0.021" or 0.53 mm. It is strictly forbidden to use galvanized steel.

Your smoke pipe should be assembled in such a way that the male section of the pipe faces down. Attach each of the sections to one another with three equidistant metal screws.

The pipe must be short and straight. All sections installed horizontally must slope at least 1/4 inch per foot, with the upper end of the section toward the chimney.

To insure a good draught, the total length of the coupling pipe should never exceed 8' to 10' (2.4 to 3.04 m). (Except for cases of vertical installation, cathedral-roof style where the smoke exhaust system can be much longer and connected without problem to the chimney at the ceiling of the room).

There should never be more than two 90 degrees elbow in the smoke exhaust system.

Installation of a "barometric draught stabiliser" (fireplace register) on a smoke exhaust system is not recommended.

Furthermore, installation of a draught damper is strictly prohibited. Indeed, with a controlled combustion wood stove, the draught is regulated upon intake of the combustion air in the stove and not at the exhaust.

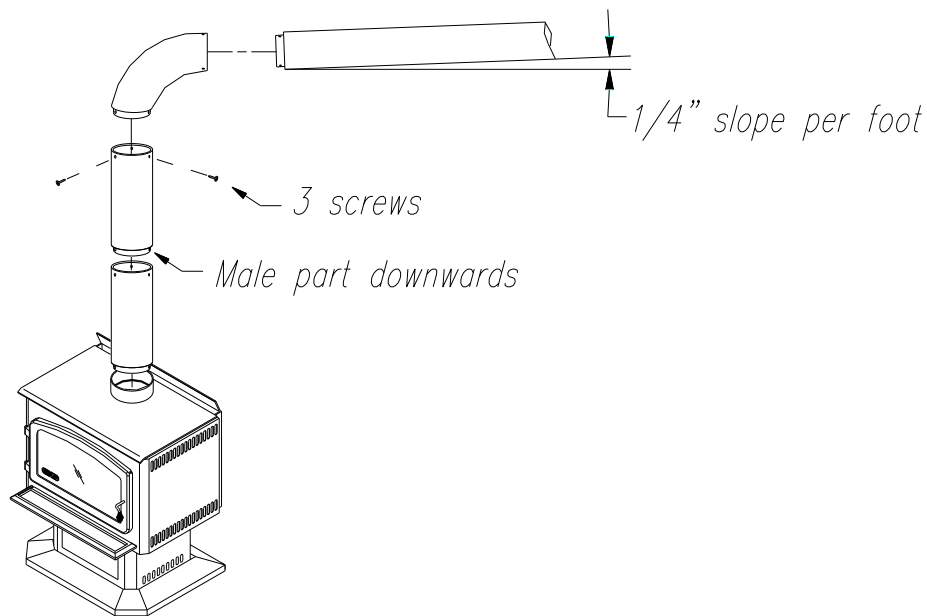

Stove Pipe

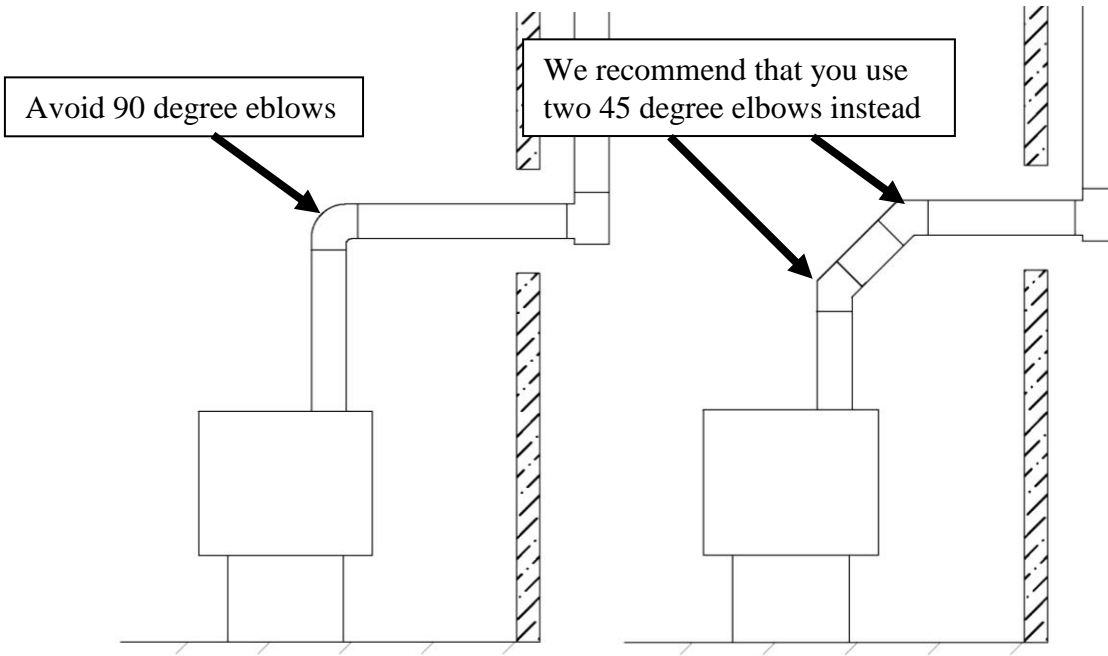

TYPICAL INSTALLATIONS

FACTORY BUILT CHIMNEY:

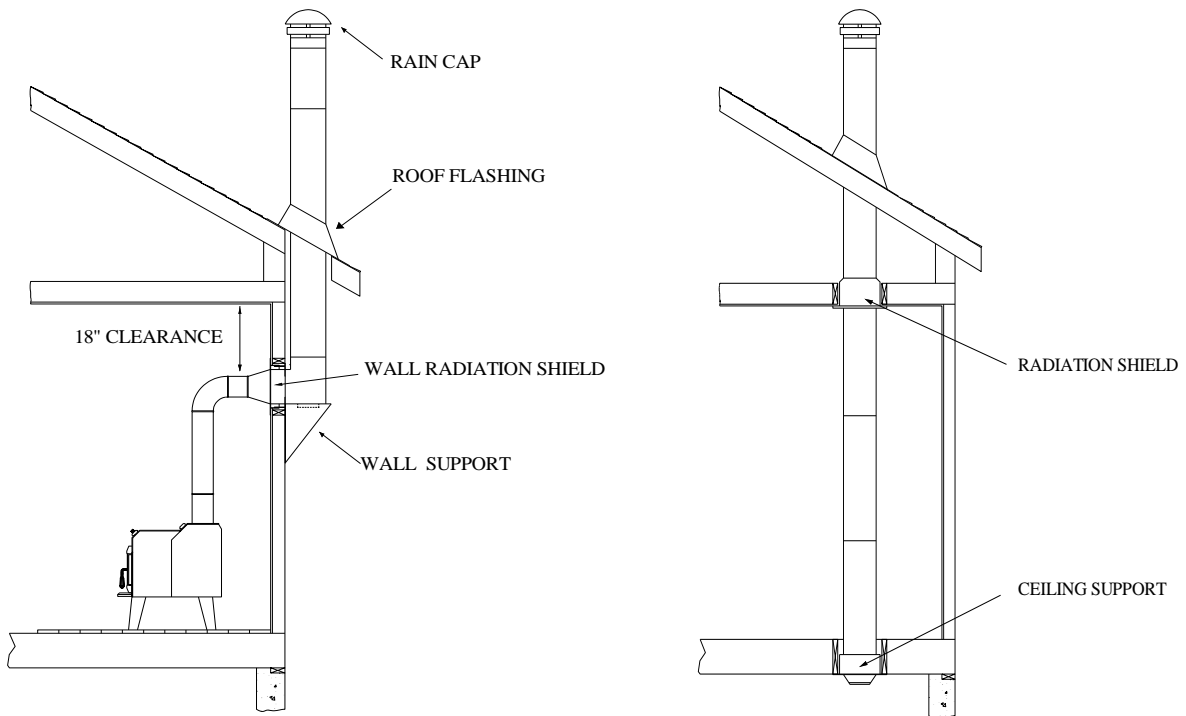

Wall installation

Vertical installation

MASONRY CHIMNEY:

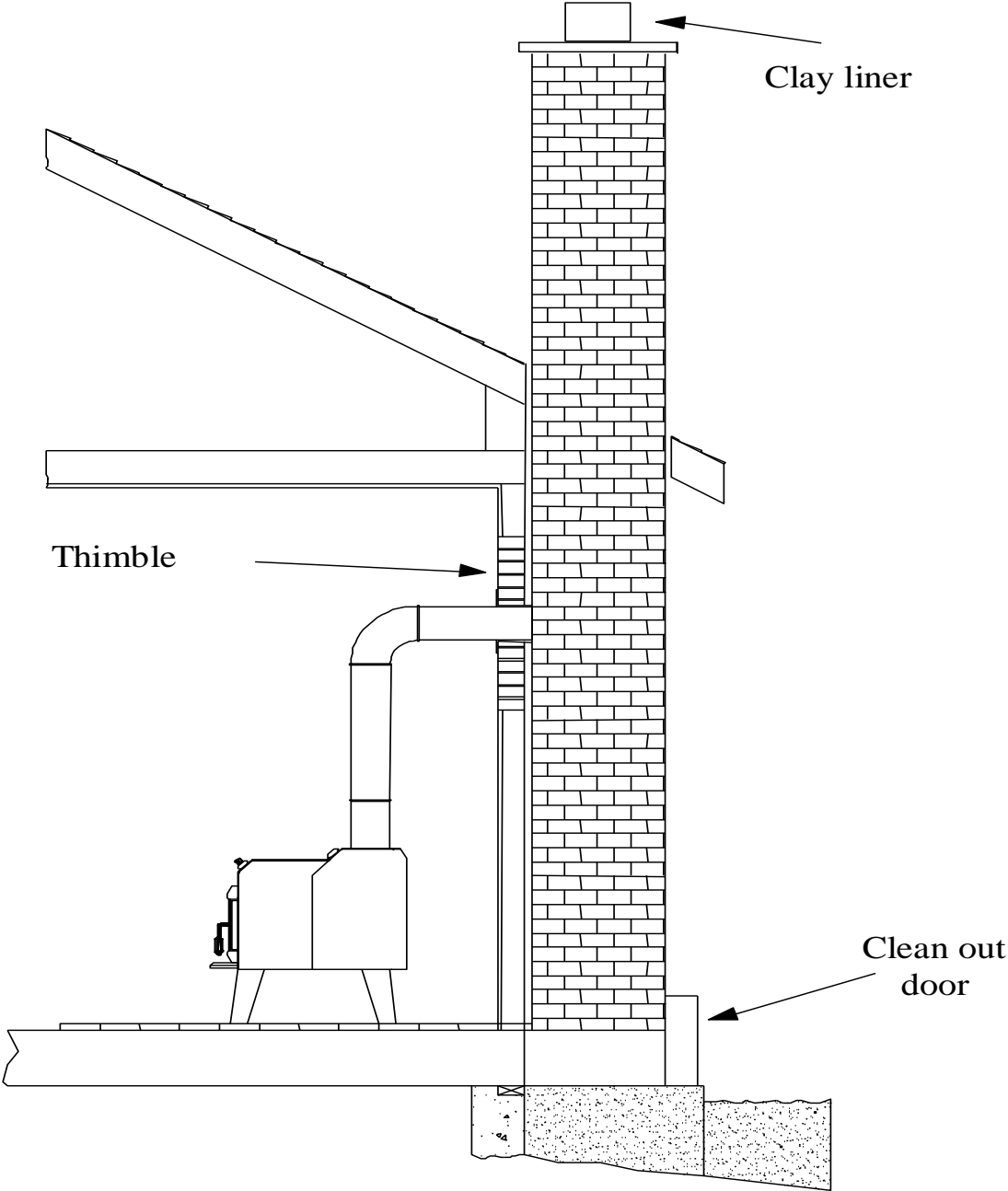

FACTORY BUILT THIMBLE:

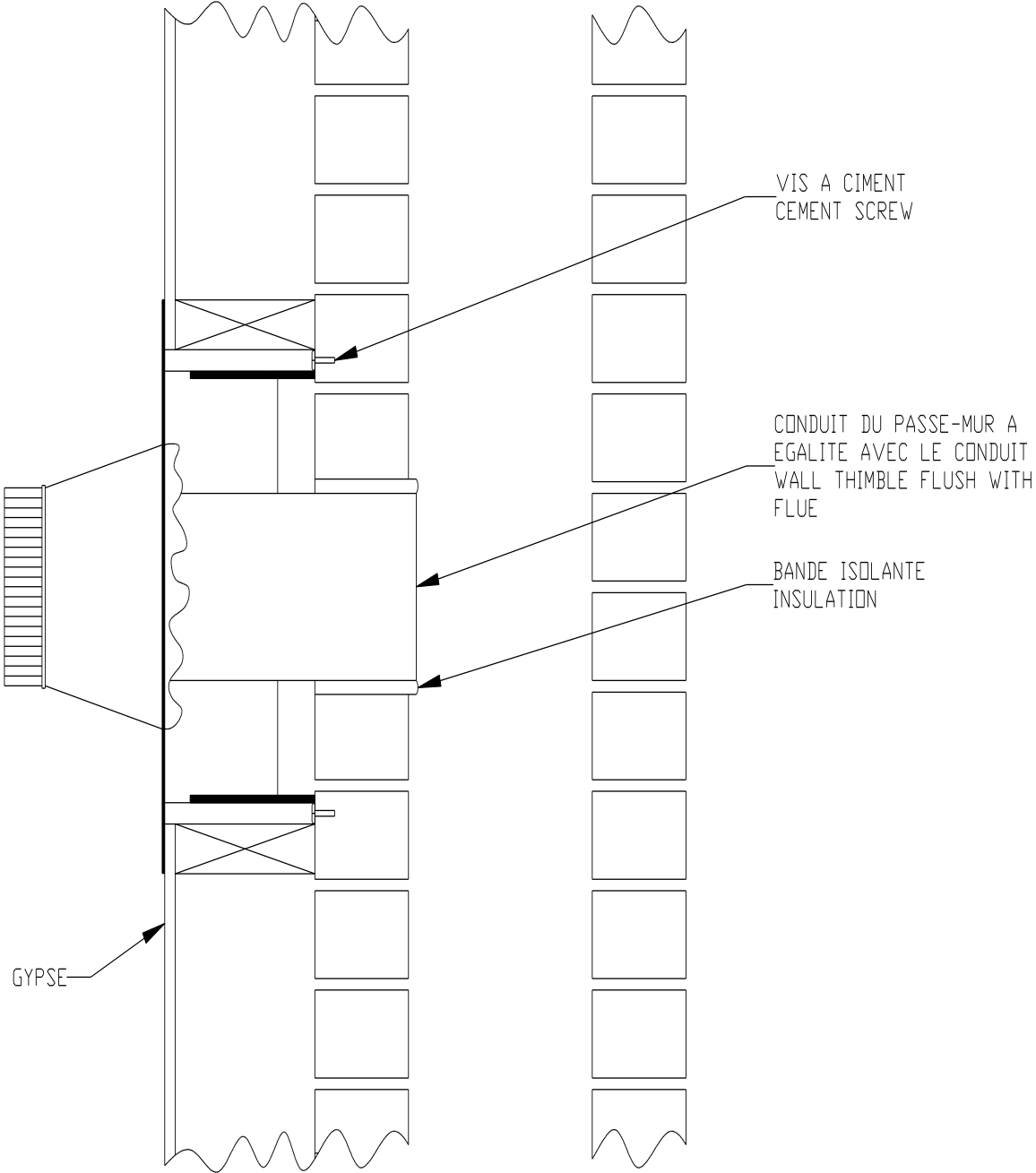

BRICK THIMBLE:

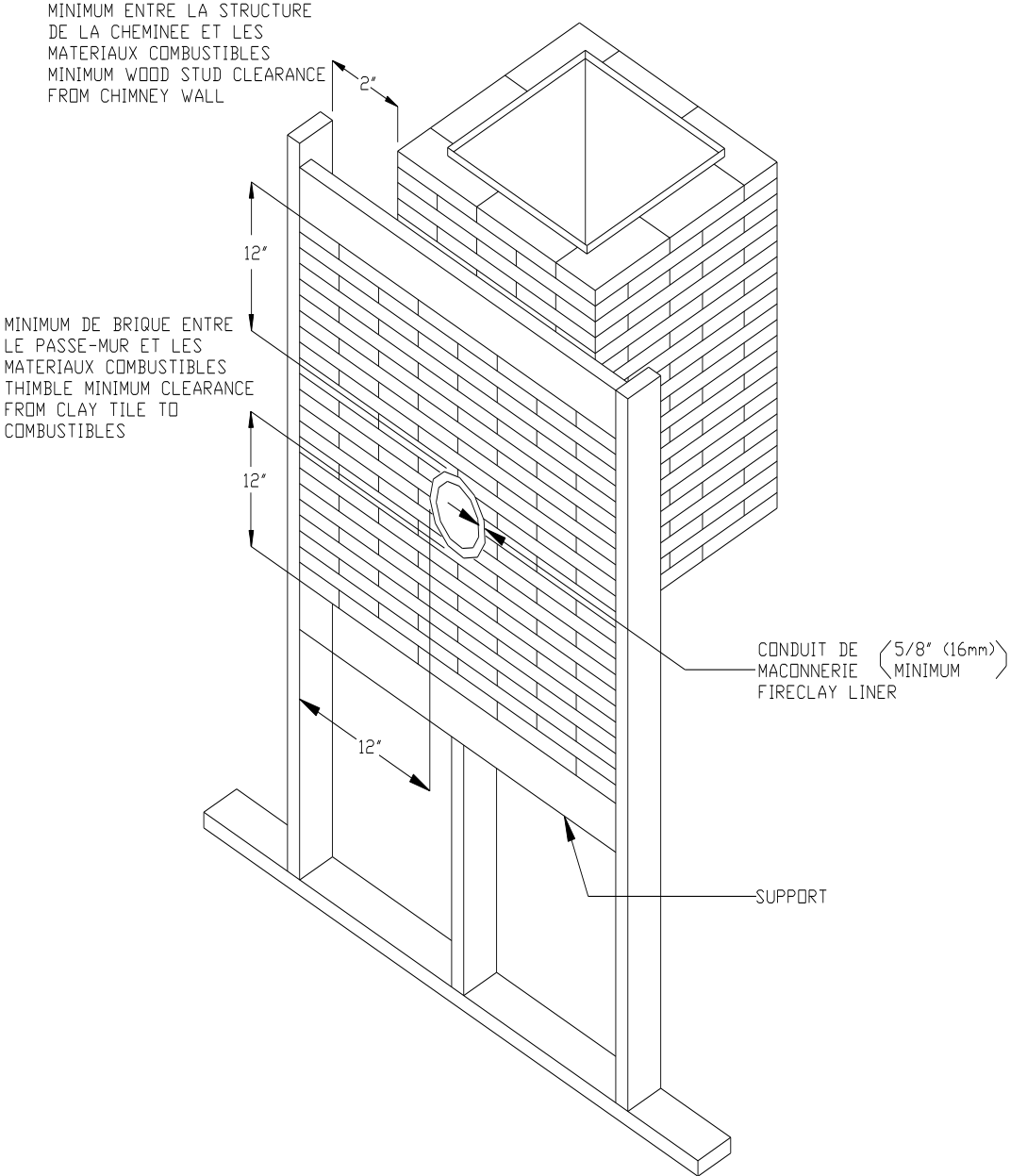

OUTSIDE COMBUSTION AIR

Your DROLET stove is approved to be installed with an outside air intake which is necessary for a mobile home. This type of installation is also required in air tight houses and houses with negative pressure problems. You can purchase this option through your DROLET dealer. Make sure to specify this part number: #AC02080. Installation instructions are supplied with the air intake kit.

Outside combustion air may be required if:

1. Your stove does not draw steadily, smoke rollout occurs, wood burns poorly, or back-drafts occur whether or not there is combustion present.
2. Existing fuel-fired equipment in the house, such as fireplaces or other heating appliances, smell, do not operate properly, suffer smoke roll-out when opened, or back-drafts occur whether or not there is combustion present.
3. Opening a window slightly on a calm (windless) day alleviates any of the above symptoms.
4. The house is equipped with a well-sealed vapour barrier and tight fitting windows and/or has any powered devices that exhaust house air.
5. There is excessive condensation on windows in the winter.
6. A ventilation system is installed in the house.

WARNINGS for use in MOBILE HOMES:

- DO NOT INSTALL IN SLEEPING ROOM.
- THE STRUCTURAL INTEGRITY OF THE MOBILE HOME FLOOR, WALL, AND CEILING/ROOF MUST BE MAINTAINED.
- THE STOVE MUST BE ATTACHED TO THE STRUCTURE OF THE MOBILE HOME.
- INSTALL IN ACCORDANCE WITH 24 CFR, PART 3280 (HUD).
- USE A FACTORY BUILT CHIMNEY THAT COMPLY WITH UL 103 OR ULC S629 STANDARDS; THEREFORE IT MUST BE A TYPE HT (2100 °F).

WOOD STOVE UTILISATION

Your heating unit was designed to burn wood only; no other materials should be burnt. Wastes and other flammable materials should not be burnt in your wood stove. Any type of wood may be used in your stove, but specific varieties have better energy yields than others. Please consult the following table in order to make the best possible choice.

AVERAGE ENERGY YIELD OF ONE AIR DRIED CORD OF CUT WOOD

	Wood species	Energy yield (millions of BTU/cord)
High energy yield	Oak	29
	Sugar Maple	28
	Beech	26
	Yellow birch	25
	Ash	24
	Elm	23
Medium energy yield	Larch (Tamarack)	23
	Red Maple	23
	Douglas red fir	23
	Silver birch	22
	Alder	18
	Poplar	17
	Hemlock	17
Low energy yield	Spruce	17
	Pine	17
	Bass	16
	Fir	13

Data provided by Energy, Mines and Resources - Canada

IT IS EXTREMELY IMPORTANT THAT YOU USE DRY WOOD ONLY IN YOUR WOOD STOVE. The wood must have dried for 9 to 15 months, such that the humidity content (in weight) is reduced below 20% of the weight of the log. It is very important to keep in mind that even if the wood has been cut since one, two or even more years, it is not necessarily dry, if it has been stored in poor conditions; under extreme conditions, it may even rot instead of drying. The vast majority of the problems related to the operation of a wood stove are caused by the fact that the wood used was too damp or had dried in poor conditions. These problems can be:

- ignition problems
- creosote build-up causing chimney fires
- low energy yield
- blackened windows
- incomplete log combustion

Smaller pieces of wood will dry faster. All logs exceeding 6" in diameter should be split. The wood should not be stored directly on the ground. Air should circulate through the cord. A 24" to 48" air space should be left between each row of logs, which should be placed in the sunniest location possible. The upper layer of wood should be protected from the element but not the sides.

TESTING YOUR WOOD

When the stove is thoroughly warmed, place one piece of split wood (about five inches in diameter) parallel to the door on the bed of red embers.

Keep the air control full open by pulling on it and close the door. If ignition of the piece is accomplished within 90 seconds from the time it was placed in the stove, your wood is correctly dried. If ignition takes longer, your wood is damp.

If your wood hisses and water or vapour escapes at the ends of the piece, your wood is soaked or freshly cut. Do not use this wood in your stove. Large amounts of creosote could be deposited in your chimney, creating potential conditions for a chimney fire.

THE FIRST FIRES

The fresh paint on your stove needs to be cured to preserve its quality. Once the fuel charge is properly ignited, only burn small fires in your stove for the first four hours of operation. Never open the air control more than necessary to achieve a medium burn rate.

Make sure that there's enough air circulation while curing the stove. The odours could be smelled during the 3 or 4 first fires. Never start your stove outside. You will not be able to see if you are over heating.

IGNITION

After making sure that the stove air intake controls are fully open (completely pull-out towards you), place several rumpled sheets of paper in the centre of the combustion chamber. Place 8 to 10 pieces of small dry kindling wood over the paper in the form of a tent. You may also place a few pieces of heating wood, but choose the smaller ones. No chemical product should be used to light the fire.

Before igniting the paper and kindling wood, it is recommended that you warm up the chimney. This is done in order to avoid back draft problems often due to negative pressure in the house. If such is the case, open a window slightly near the stove and twist together a few sheets of newspaper into a torch. Light up this paper torch and hold it as close as possible to the mouth of the pipe inside the combustion chamber to warm up the chimney. Once the updraft movement is initiated, you are ready to ignite the stove by lighting the paper and kindling wood inside the combustion chamber.

We therefore advise you to leave the door slightly opened (1/4") for a 10 to 30 minutes period, **under supervision**, in order to allow for good combustion. After this time, you must close the door and progressively adjust the air control to obtain the desired temperature.

HEATING

Controlled combustion is the most efficient technique for wood heating because it enables you to select the type of combustion you want for each given situation. The wood will burn slowly if the wood stove air intake control is adjusted to reduce the oxygen supply in the combustion chamber to a minimum. On the other hand, wood will burn quickly if the air control is adjusted to admit a larger quantity of oxygen in the combustion chamber. The air intake control on your stove is very simple. If you pull on it out completely towards you, it is fully open. If you push on it until it stops the combustion air is reduced to a minimum.

Your DROLET stove burnt between .953 kg\h et 3.639 kg\h. of wood during EPA testing. Real operating conditions may give very different results than those obtained in the lab according to the species of wood used, it's moisture content, the size and density of the pieces, the length of the chimney, altitude and outside temperature.

WARNINGS

- NEVER OVER FIRE YOUR STOVE. IF ANY PART OF THE STOVE STARTS TO GLOW RED, OVER FIRING IS HAPPENING. READJUST THE AIR INTAKE CONTROL AT A LOWER SETTING.
- THE INSTALLATION OF A LOG CRADLE IS NOT RECOMMENDED IN YOUR DROLET WOOD STOVE.
- NEVER PUT WOOD ABOVE THE FIREBRICK LINING OF THE FIREBOX.
- NEVER PUT WOOD OVER THE LOG RETAINER LOCATED ON THE FRONT LOWER PART OF THE FIREBOXE (SEE NEXT FIGURE).

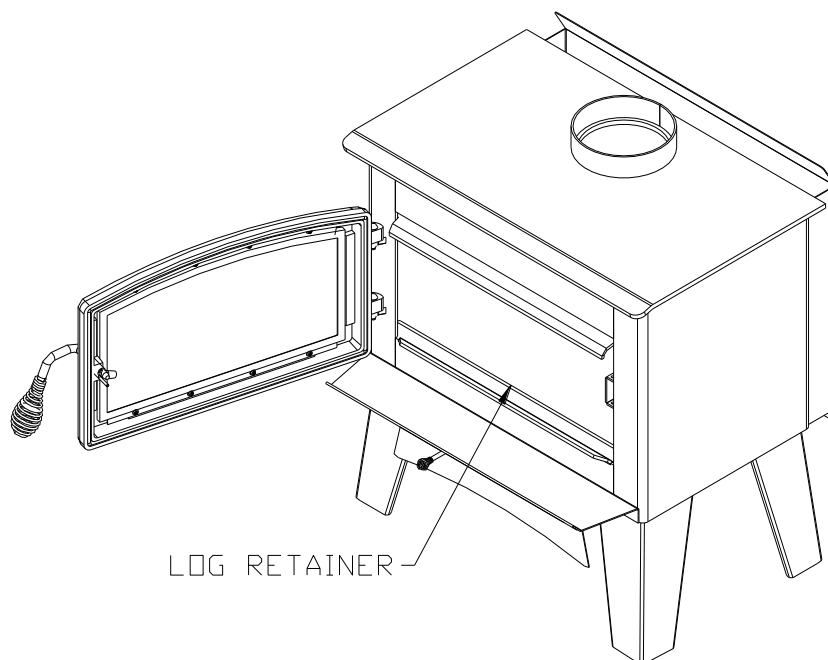

RELOADING

Once you have obtained a good bed of embers, you should reload the unit. In order to do so, open the air controls to maximum a few seconds prior to opening the stove's door. Then proceed by opening the door very slowly; open it one or two inches for 5 to 10 seconds, before opening it completely to increase the draught and thus eliminate the smoke which is stagnant in a state of slow combustion in the stove. Then bring the red embers to the front of the stove and reload the unit.

For optimal operation of your wood stove, we recommend you operate it with a wood load approximately equivalent to the height of fire bricks.

It is important to note that wood combustion consumes ambient oxygen in the room. In the case of negative pressure, it is a good idea to allow fresh air in the room, either by opening a window slightly or by installing a fresh air intake system on an outside wall. Refer to page 16 of the present manual.

In order to achieve an optimum efficiency from your unit, we suggest that you operate it with the air control slightly open (approximately 10%). Make sure that you have a good fire going and an adequate ember bed before you completely close the air control. Use a chimney thermometer if necessary. Closing the air control too soon will lower combustion efficiency and may cause the fire to die out. The addition of a blower (if not already included) is highly recommended to maximize your unit's efficiency.

CREOSOTE FORMATION AND NEED FOR REMOVAL

When wood is burned slowly, it produces tar and other organic vapours, which combine with expelled moisture to form creosote. The creosote vapours condense in the relatively cool chimney flue of a slow-burning fire. As a result, creosote residue accumulates on the flue lining. When ignited this creosote makes an extremely hot fire. When burning wood, the chimney connector and chimney should be inspected at least once every two months during the heating season to determine if a creosote build-up has occurred.

We strongly recommend that you install a magnetic thermometer on your smoke exhaust pipe, approximately 18" above the stove. This thermometer will indicate the temperature of your gas exhaust fumes within the smoke exhaust system. The ideal temperature for these gases is somewhere between 275 °F and 500 °F. Below these temperatures, the build-up of creosote is promoted. Above 500 degrees, heat is wasted since a too large quantity is lost into the atmosphere.

TO PREVENT CREOSOTE BUILD UP

- Always burn dry wood. This allows clean burns and higher chimney temperatures, therefore less creosote deposit.
- Leave the air control full open for about 10 min. every time you reload the stove to bring it back to proper operating temperatures. The secondary combustion can only take place if the firebox is hot enough.
- Always check for creosote deposit once every two months and have your chimney cleaned at least once a year.

ASH DISPOSAL

Ashes should be removed from the stove every few days or when ashes get to 2 to 3 inches deep. Always empty the stove when it is cold, such as in the morning.

Always dispose of ashes in a metal container with a tight fitting lid. Place this container on a non combustible floor or on the ground, well away from all combustible materials, pending final disposal. If the ashes are disposed of by burial in soil or otherwise locally dispersed, they should be retained in the close container until all cinders have thoroughly cooled.

CAUTIONS:

- ASHES COULD CONTAIN HOT EMBERS EVEN AFTER TWO DAYS WITHOUT OPERATING THE STOVE.
- THE ASH PAN CAN BECOME VERY HOT. WEAR GLOVES TO PREVENT INJURY.
- NEVER BURN THE STOVE WITH THE ASH TRAP OPEN. THIS WOULD RESULT IN OVER FIRING THE STOVE. DAMAGE TO THE STOVE AND EVEN HOUSE FIRE MAY RESULT.

MAINTENANCE

Your Drolet stove is a high efficiency stove and therefore requires little maintenance. It is important to perform a visual inspection of the stove every time it is emptied, in order to insure that no parts have been damaged, in which case repairs must be performed immediately.

GLASS

- Inspect the glass regularly in order to detect any cracks. If you spot one, turn the stove off immediately. Do not abuse the glass door by striking or slamming shut. Do not use the stove if the glass is broken.
- If the glass on your stove breaks, replace only with glazing supplied from the Drolet dealer.
- To replace the glass, remove the screws retaining the glass mouldings inside the door. Remove the mouldings and replace the damaged piece with a new one. Perform the procedure backwards after replacing. When replacing the glass, you should change the glass gasket to make sure you keep it sealed.
- Never wash the glass with a product that may scratch. Use a specialized product, available in the stores where wood stoves are sold.
- The glass should be washed only when cold.

GASKETING

It is recommended that you change the door gasket (which makes your stove door air tight) once a year, in order to insure good control over the combustion, maximum efficiency and security. To change the door gasket, simply remove the damaged one. Carefully clean the available gasket groove, apply a high temperature silicone sold for this purpose, and install the new gasket. You may light up your stove again approximately 24 hours after having completed this operation.

WARNING:

- NEVER OPERATE THE STOVE WITHOUT A GASKET OR WITH A BROKEN ONE. DAMAGE TO THE STOVE OR EVEN HOUSE FIRE MAY RESULT

PAINT

Only clean your stove with a dry soft cloth that will not harm the paint finish.

If the paint becomes scratched or damaged, it is possible to give your wood stove a brand new look, by repainting it with a 1200 °F heat resistant paint. For this purpose, simply scrub the surface to be repainted with fine sand paper, clean it properly, and apply thin coats (2) of paint successively. Refer to page 18 of the present manual for the paint curing process.

DROLET LIMITED LIFETIME WARRANTY

The warranty of the manufacturer extends only to the original consumer purchaser and is not transferable. This warranty covers brand new products only, which have not been altered, modified nor repaired since shipment from factory. Proof of purchase (dated bill of sale), model name and serial number must be supplied when making any warranty claim to your DROLET dealer.

This warranty applies to normal residential use only. Damages caused by misuse, abuse, improper installation, lack of maintenance, over firing, negligence or accident during transportation are not covered by this warranty.

This warranty does not cover any scratch, corrosion, warping, or discoloration caused by over firing, abrasives or chemical cleaners. Any defect or damage caused by the use of unauthorized parts or others than original parts void this warranty. An authorized qualified technician must perform the installation in accordance with the instructions supplied with this product and all local and national building codes. Any service call related to an improper installation is not covered by this warranty.

The manufacturer may require that defective products be returned or that digital pictures be provided to support the claim. Returned products are to be shipped prepaid to the manufacturer for investigation. If a product is found to be defective, the manufacturer will repair or replace such defect and reasonable transportation fees will be refunded. Repair work covered by the warranty, executed at the purchaser's domicile by an authorized qualified technician requires the prior approval of the manufacturer. Labour cost and repair work to the account of the manufacturer are based on predetermined rate schedule and must not exceed the wholesale price of the replacement part. All labour and freight costs covered by this warranty are limited according to the table below.

The manufacturer at its discretion may decide to repair or replace any part or unit after inspection and investigation of the defect. The manufacturer may, at its discretion, fully discharge all obligations with respect to this warranty by refunding the wholesale price of any warranted but defective parts. The manufacturer shall in no event be responsible for any special, indirect, consequential damages of any nature, which are in excess of the original purchase price of the product. This warranty applies to products purchased after March 1st 2009.

DESCRIPTION	WARRANTY APPLICATION	
	PARTS	LABOUR
Combustion chamber (welds only), castings, and convector airmate	Lifetime	5 years
Plating (defective manufacture) – subject to limitations above	Lifetime	n/a
Secondary air tubes, vermiculite baffle, C-Cast baffle and handle assembly	5 years	n/a
Stainless steel baffle and parts	5 years	3 years
Carbon steel baffle and parts	2 years	1 year
Blowers, thermal switches, rheostat, and other controls	2 years	1 year
Paint (peeling), gaskets, insulation, and ceramic glass (thermal breakage only*)	1 year	n/a

**Pictures required*

Shall your unit or a components be defective, contact immediately your **DROLET** dealer. Prior to your call make sure you have the following information necessary to your warranty claim treatment:

- Your name, address and telephone number;
- Bill of sale and dealer's name;
- Serial number and model name as indicated on the nameplate fixed to the back of your unit;
- Nature of the defect and any relevant information.

Before shipping your unit or defective component to our plant, you must obtain from your DROLET dealer an Authorization Number. Any merchandise shipped to our plant without authorization will be refused automatically and returned to sender.