

INSTALLATION INSTRUCTIONS

Kozy Heat

FIREPLACE HEATING SYSTEM

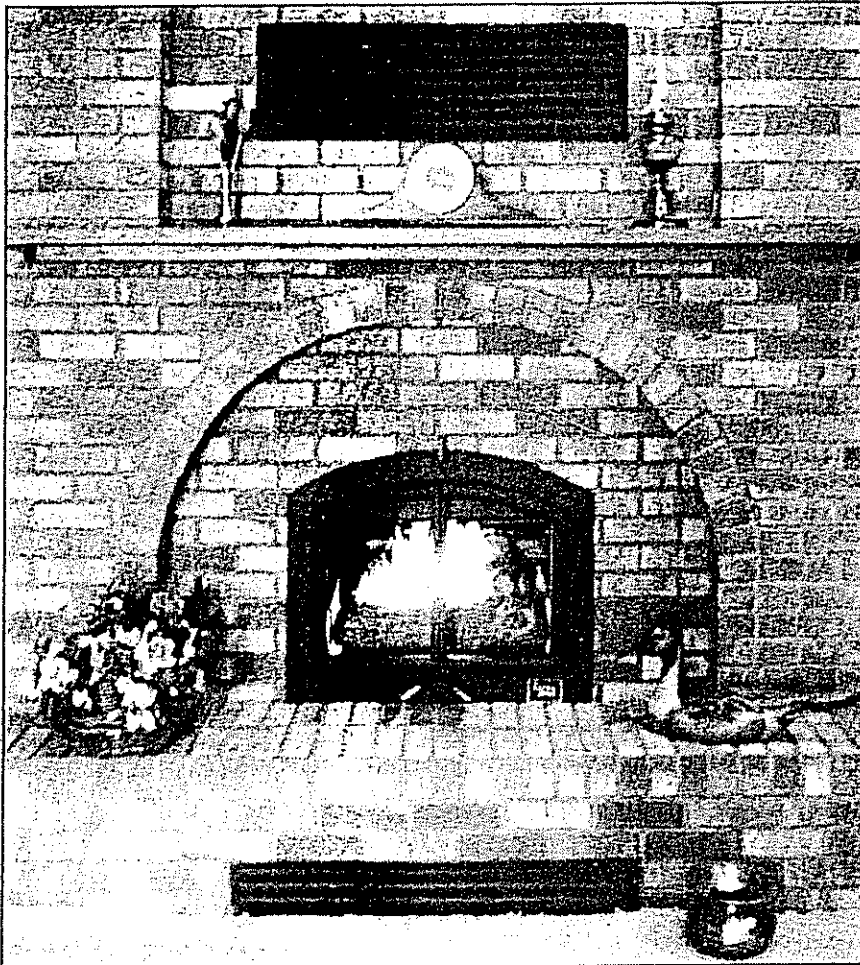

IMPORTANT:

READ INSTRUCTIONS CAREFULLY BEFORE
INSTALLATION. FAILURE TO INSTALL THIS
FIREPLACE CORRECTLY CAN CAUSE
SERIOUS STRUCTURAL AND FIRE HAZARDS
AND MAY VOID YOUR WARRANTY.

Model 231-B
231-G

Form #2004
November 2004

READ ALL INSTRUCTIONS BEFORE INSTALLING

MOST COMMON INSTALLATION PROBLEMS

Fire Hazards

- A) No wood should be left inside of the block chamber.
- B) If installing the block chamber adjacent to a combustible wall leave at least 4" of space between outside of the block and a wood wall. Insulate with non-faced fiberglass insulation.
- C) Use only non-combustible insulation. DO NOT USE STYROFOAM.
- D) At least 12" of space must be left between the top of the chamber and any combustibles. Place at least 6" of non-faced fiberglass insulation on top of the slab.
- E) The top of the upper grill must be level with the bottom of the slab to prevent a heat sink.
- F) This unit must be connected to its own chimney system.

Cold Air Transfer Areas

- A) The outside walls around the fireplace must be insulated just like any other wall in your home, if they are not, you will have a cold air transfer.
- B) The foundation slab directly under the fireplace must not extend to the outside of the house, see figure 3 for proper installation. If this is not done you will have a severe cold air draft through the bottom grill.
- C) Secure combustion air pipe together with screws to prevent them from coming apart and leaking cold air into your chamber.
- D) The outside air vent and cover should be of the same dimension as the outside air pipe, i.e., 4" or 6" round to prevent leaks around the connection. Kozy Heat has an outside air vent with closure available. Contact your local dealer.

Face Brick Cracking

- A) Do not lay face brick directly on top of the unit or the face, use a lintel iron (included) across the top of the unit making sure a 1/2" space is left between the unit and the lintel.
- B) Do not allow mortar to fall between lintel and the unit. This can be prevented by using fiberglass insulation that is placed against the back side of the lintel.
- C) Allow at least 3/8" of space between face brick and sides of the unit. Do not set the faceplate on the hearth brick.

Chimney/Intake Pipe Problems

- A) Clay flue chimneys with a block and/or brick surround contain a large amount of moisture and can also absorb moisture during installation if not properly covered at night, etc. Because of this situation it is best to have small fires until the chimney has dried out and no longer appears "green." This will be accomplished by burning the unit at low to moderate temperatures (flue gas temps should not exceed 500°F) for at least five days. If this is not done cracking of the block or flue liner could occur.
- B) Do not reduce or modify the air intake pipe. Do not reduce the required opening at the point of termination, as this can cause a restriction in the units ability to burn adequately.
- C) Use a louvered vent cover with a screen at the point of termination. Do not use extremely fine mesh screen.

Smoking Back

- A) Do not reduce the size of the chimney, the unit will smoke back. An 8" x 8" clay flue has a 6 1/2" diameter I.D. and will not work with any Kozy Heat unit. An 8" Chimtek Chimney or a 8" Standard, not modular, clay flue or a 9" x 13" clay flue may be used with the 231. Follow NFPA Standards.
- B) The chimney should be at least 10' tall (above the fireplace) and at least 3' higher than the peak of the house.
- C) If an adaptor (P) in Fig. 1 (included with unit) is not used a creosote leak could occur at this connection causing a rancid smoke smell in your home. See your warranty.

INSTALLATION

Minimum clearances to combustibles:

- A) Unit back to block enclosure 4"
- B) Unit sides to block enclosure 3"
WARNING: Do not pack air space between unit and block enclosure with insulation or other materials.
- C) Block enclosure to combustible walls 4"
NOTE: Combustible walls surrounding the block enclosure must be filled with non-faced fiberglass insulation.
- D) Top of fuel opening to combustible mantle 16"
- E) Top of chamber top slab to joists or rafters 12"
NOTE: Top slab must be covered with 6" of non-faced fiberglass insulation.
- F) Side of fuel opening to a perpendicular combustible wall 24"
- G) Side trim from fuel opening 8"

FIGURE 1

1. Build a form for the chamber top slab (A) at this time. The dimensions required are 36" x 27" x 3½" deep. Use the chamber top purchased with the unit, (B) or construct one of 10 gauge metal, 36" x 24" with a 4" extension. A wooden form may be used, or you may use face brick, as they provide holes with which to hold to re-rod.

a) Wrap insulation (C) around the adaptor (D) and place the adaptor into the form. The adaptor must rest on top of the slab, use a couple of re-rods (E) to hold the adaptor up until the slab has set up. The placement of the adaptor will vary if an offset stack is used.

b) Pour the slab. While the concrete is still wet inset the required amount of re-rods into position (F).

NOTE: By pouring the concrete at this time, it will be properly dried by the time the chamber walls have been completed. At that time the chamber top slab can simply be lifted into position and mortared to the chamber walls.

c) When the slab has set up, remove the clay flue adaptor, and wood forms.

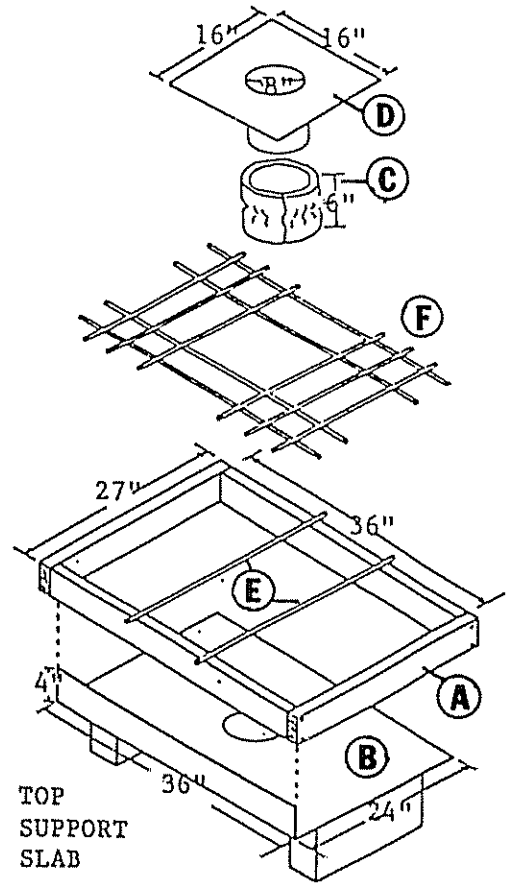

Fig. 1
TOP
SUPPORT
SLAB

FIGURE 2

2) Dig foundation depth to conform with frost level. Foundation hole must be a minimum of 38" x 60", to allow for frost barrier.

3) Set up and pour foundation concrete slab 36" x 56", 12" thick with re-rod. See re-rod requirements, Fig. 7. If a vast amount of brick is being used, or if a masonry chimney 19' or taller is being used, make foundation 18" thick with re-rod. This foundation may be located on an outside wall or inside the house.

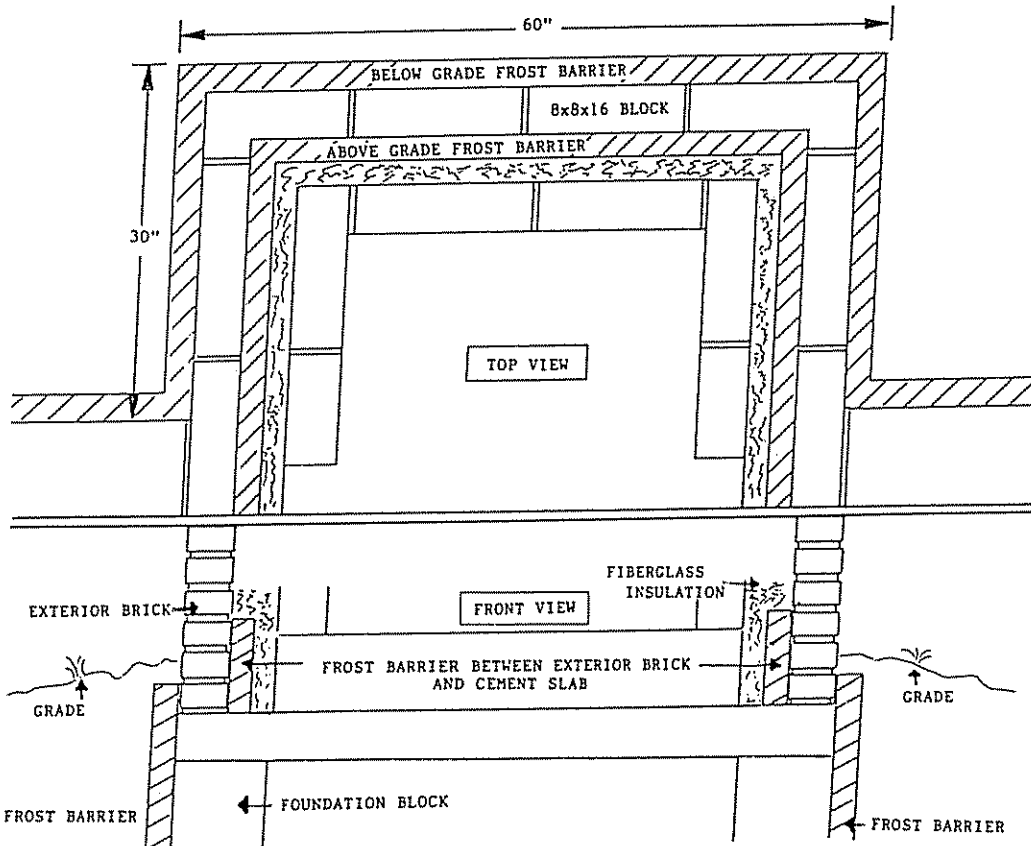

Fig. 2

FIGURE 3

- 4) Lay up regular 8" x 8" x 16" concrete block (G) from the foundation to 4" below ground level. Wrap the block with 2" of blueboard/styrofoam insulation to create a frost barrier.
 - a) Set up a form and pour a slab (H) 36" x 56" x 4" thick, with an upward extension slab (I) 28" x 40" x 4" thick. Wrap the 28" x 40" slab with 2" of blueboard/styrofoam insulation, and 2" of fiberglass insulation, to create a frost barrier.

CAUTION: Do not use blueboard/styrofoam insulation above the fireplace foundation level.
 - b) If an ash pit is to be used, leave a 5" x 10" in the slab. See firebrick layout, Fig. 6, for proper placement of the hole. The ash chute must be properly sealed to the firebox and to the cement slab to prevent air flow into the unit. Furnace cement or mortar may be used.
 - c) The foundation block can be used as an ash pit, if desired. Install a clean out door above ground level, or in the basement. An air tight door must be used.

- 5) The hearth extension foundation (J) should also be completed at this time.

CAUTION: The hearth extension must be placed on non-combustible flooring. If the unit is to be installed without a raised hearth a non-combustible hearth must extend 24" in front of and 8" beyond the sides of the fuel opening. If installing with a raised hearth (J), it must extend 16" in front of and 8" beyond the sides of the fuel opening. The hearth must be installed only as illustrated.

NOTE: It is recommended that the lower grill (K) be placed in the hearth extension for the best air flow.

- 6) If installing the optional blower, a metal junction box should be centrally located in the slab below the unit and metal conduit routed to the desired switch locations. The blower should be plugged into this receptacle. See Fig. 5 for proper placement.

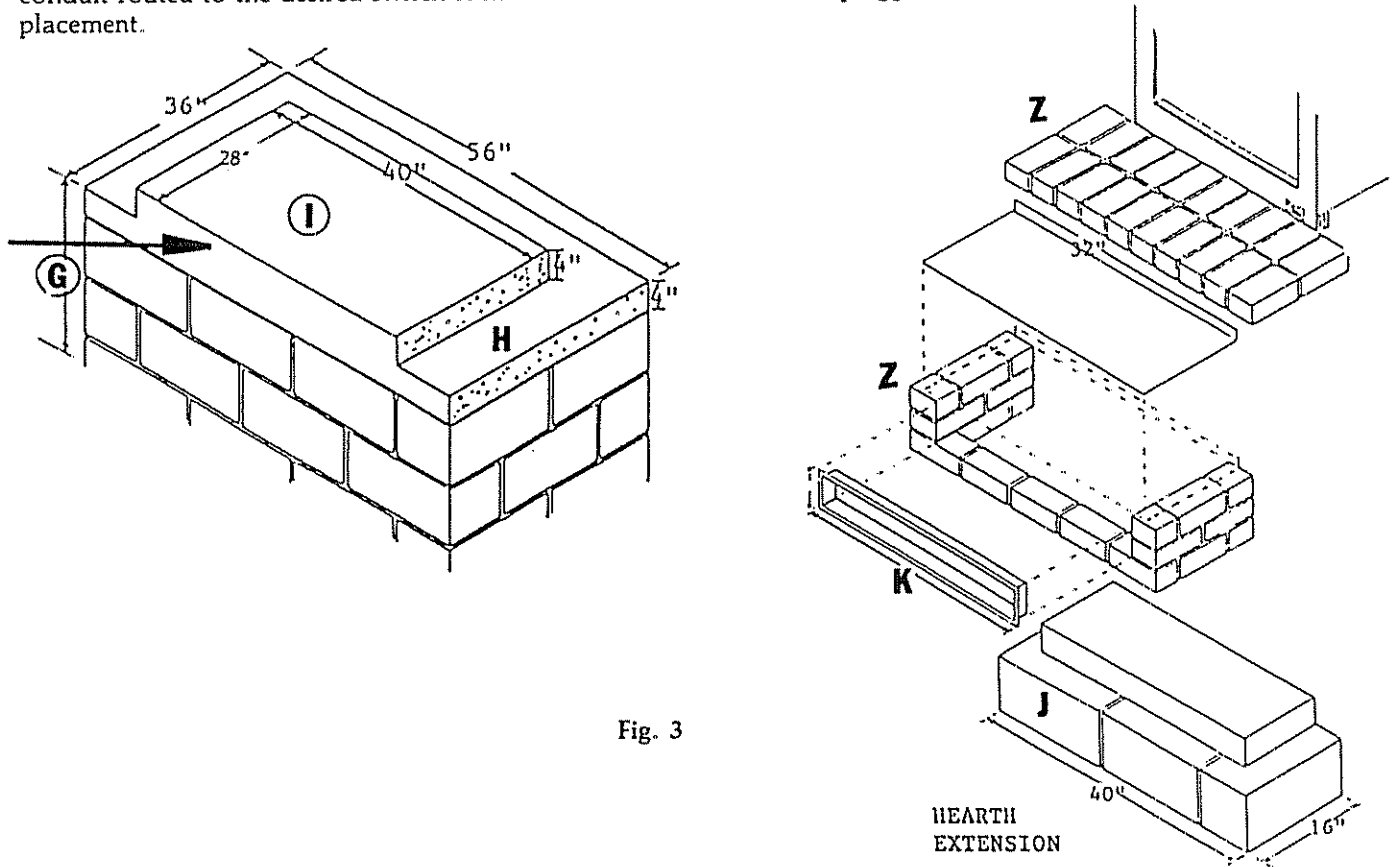

Fig. 3

FIGURE 4

- 7) Lay up the inner chamber walls (L), constructed of 4" x 8" x 16" light weight or regular concrete block. See Figure 4B for actual course requirements, and the number of blocks needed.

NOTE: Keep this wall 4" back from the desired front of the fireplace to allow the face brick to be installed in front of it, and behind the fireplace faceplate.

NOTE: If installing adjacent to combustible materials leave 4" of space between the chamber walls and the combustible materials. Fill the space with non-faced fiberglass insulation. DO NOT USE STYROFOAM OR BLUEBOARD INSULATION.

- a) Metal ties should be used on the ends of this wall to tie the facebrick to the block chamber walls to insure a seal.
- b) As the wall progresses to the height of the combustion air intake, at the fifth course of block, stub the 4" intake (M) through the chamber wall and seal with mortar. Use 30 gauge or heavier galvanized pipe from this point to the point of termination outside the house.
- c) The maximum height of the heat chamber is determined by the room ceiling height. A minimum of 17" from the ceiling to the top of the upper grill is required.
- d) If a wooden support header is used above the top slab, leave at least 12" of space between the top of the slab and the bottom of the header. Fill this area with at least 6" of non-faced fiberglass insulation.

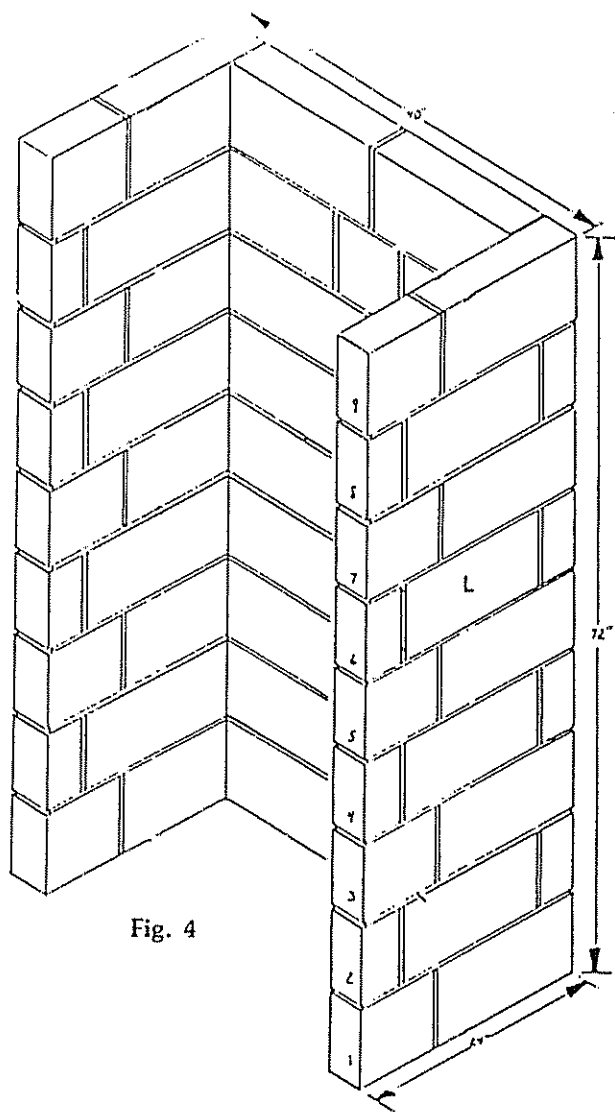

Fig. 4

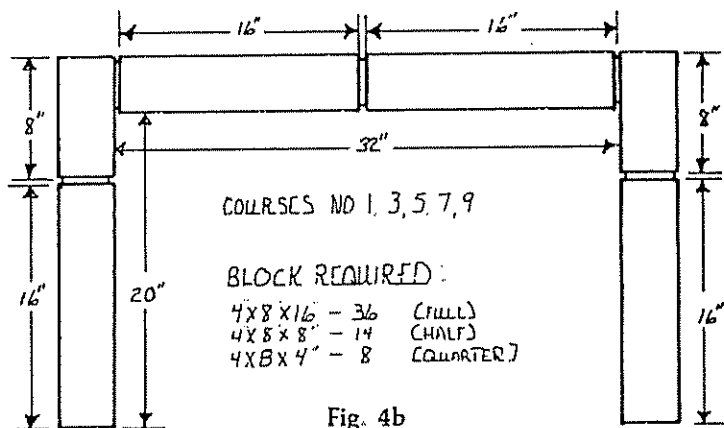
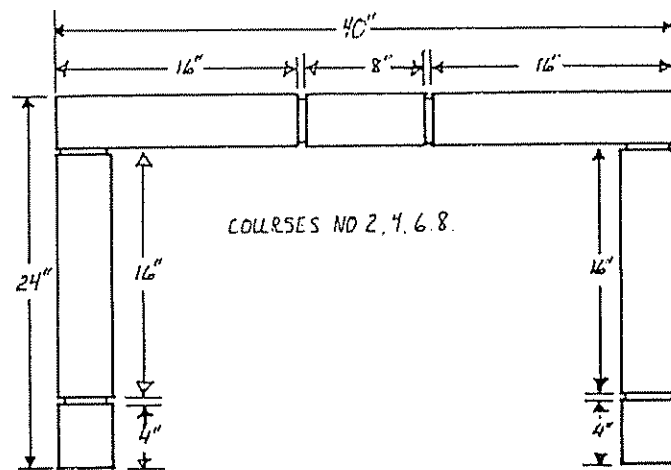

Fig. 4b

FIGURE 5

- 8) Place the model 231 fireplace (O) into the chamber with the faceplate of the fireplace 4" in front of the leading edges of the heat chamber walls, and having 3" of space from each side wall and 4" from the back chamber wall. Level and plum the unit across the top of the unit. Leveling legs (P) have been provided for this purpose. Loosen or tighten the bolts as needed.
- 9) Place the flex pipe (Q) (provided) onto the combustion air pipe (R). Connect the flex pipe to the section already placed through the chamber wall. (Step #7b.) The flexible pipe will extend to approximately 5'.

CAUTION: THIS PIPE CRUSHES EASILY. Connect by placing over the intake pipe and the galvanized pipe. **DO NOT RUN FLEX PIPE OUTSIDE THE CHAMBER WALLS.**

NOTE: If the combustion air pipe runs for any length outside of the heat chamber, but inside the house, wrap it with insulation to eliminate condensation or frost build up.

NOTE: We recommend that the secondary combustion air intake (S) not be connected to the outside, that the air be drawn from within the chamber

10) Run the primary combustion air to the outside termination using 30 gauge or heavier galvanized pipe. The combustion air can be run to the outside with various methods. If the pipe run is longer than 10' it is recommended that you increase to a 6" pipe. The maximum length recommended to run the pipe is not more than 26 feet and not more than three elbows. It is best to duct the shortest possible way. **DO NOT** terminate in the attic or into the garage. If ducting beside the chimney chase, terminate the intake air at least three feet below the termination level of the chimney. The air can also be ducted below the floor level of the fireplace providing it is ducted to the outside. A louvered screen must be used on the outside of the house.

NOTE: Do not reduce the size of the pipe at the point of termination, and do not use an extremely fine meshed screen as this will cause an air flow obstruction.

NOTE: A closure vent (N) is available to shut off the air at the outside termination of the intake pipe from inside the home. When the fireplace is not in use this eliminates any cold transfer into the home. See Kozy Heat's accessory catalog for more information on the closure and non-closure vents available. We recommend the use of this vent on all Aura-Flame installations.

11) Complete the chamber walls (L).

12) Place the connector pipe (T) onto the fireplace unit (O).

NOTE: Offset connector pipes are available in 5", 10", and 16" to connect to a chimney not centered above the unit. Offset cannot be more than a 30° angle. **DO NOT RUN SINGLE WALL METAL PIPE OUTSIDE OF THE BLOCK CHAMBER!**

13) Place the preformed top slab (U) onto the chamber walls at this time and seal with mortar.

14) There must be a 1" space (V) between the bottom of the slab and the top of the connector pipe (T). This space is necessary due to expansion and contraction of the unit while heating.

15) Place the adaptor (D) through the hole in the top plate (B) (Fig. 1) and into the connector pipe.

NOTE: A chimney adaptor is required to eliminate any chance of moisture or creosote from dripping onto the unit. An adaptor for a clay flue chimney (D) is included with your unit.

16) Place the first section of Class "A" Chimney Pipe (W) onto the adaptor (either 8" Chim-Tek or a 9" x 13" clay flue tile.)

17) Wrap the chimney sections with insulation (X) and chimney block (Y) or regular concrete block.

NOTE: THE HEADER MUST NOT HAVE DIRECT CONTACT WITH THE MASONRY BLOCK. A minimum of 2" of space should be left between the header and the chimney block.

18) Lay up the hearth brick (Z) and face brick (AA). Allow 3/8" expansion room along the side of the fireplace and 1/2" over the top, supported by the lintel iron (BB), included with the unit. It is recommended that you place fiberglass insulation against the back of the lintel to prevent mortar from getting between the lintel and the firebox.

CAUTION: If this expansion room is not left between the unit and the face brick, face brick cracking can occur, and the unit will not be able to expand when heated—as designed.

CAUTION: This face material must be a masonry product from the lower grill level to the ceiling.

19) As you lay up the face brick the damper controls should be run through the face brick (CC). They must run straight out and be parallel to the floor to avoid any binding action. They are equipped with sleeves to avoid binding where contact is made with the mortar. Do not allow mortar to fall between the intake pipe and the facebrick. It will cause the damper to stick when the unit is hot.

NOTE: If installing a mantle leave at least 16" between the top of the fuel opening and a combustible mantle.

20) Leave 4" of space between the heat chamber walls (L), and the outer wall on the sides and back (DD). Fill this space with non-faced fiberglass insulation (EE). This will prevent cold air from penetrating into the chamber. This insulation is optional on an interior installation.

21) Install the upper grill (FF). The top of the grill must be even with the bottom of the slab (U) to prevent a heat sink. The grill should be installed with the louvers pointing downward to direct the heat flow.

NOTE: As the face brick are being laid up in front of the slab, be sure that the brick are sealed by placing insulation between them and the chamber top.

- 22) Complete your chimney. A masonry chimney must be installed in accordance with the requirements of NFPA 211 Standard for Chimneys, Fireplaces & Vents. The chimney system must be installed to a height of at least three feet taller than the peak of the house. The fireplace must be installed with its own separate chimney system. **DO NOT connect to an existing flue serving another appliance.** Install metal chimneys according to manufacturer's installation instructions and clearances. See your local building inspector for specific codes in your area.
- 23) A chimney cap must be installed on top of the chimney to prevent rust from forming on the inside of the fireplace. (See warranty)
- 24) Wash the face brick.

CAUTION: DO NOT USED MURIATIC ACID. THIS CAN RESULT IN RUST ON ALL METAL SURFACES IN THE AREA.

- 25) Install firebrick on bottom, back & sides of the unit. Install firebrick above the secondary intake baffle and place the stainless steel retaining cap over the top edge. See layout, figure 6.
- 26) Place handles on chimney & intake rods and on latch handles.

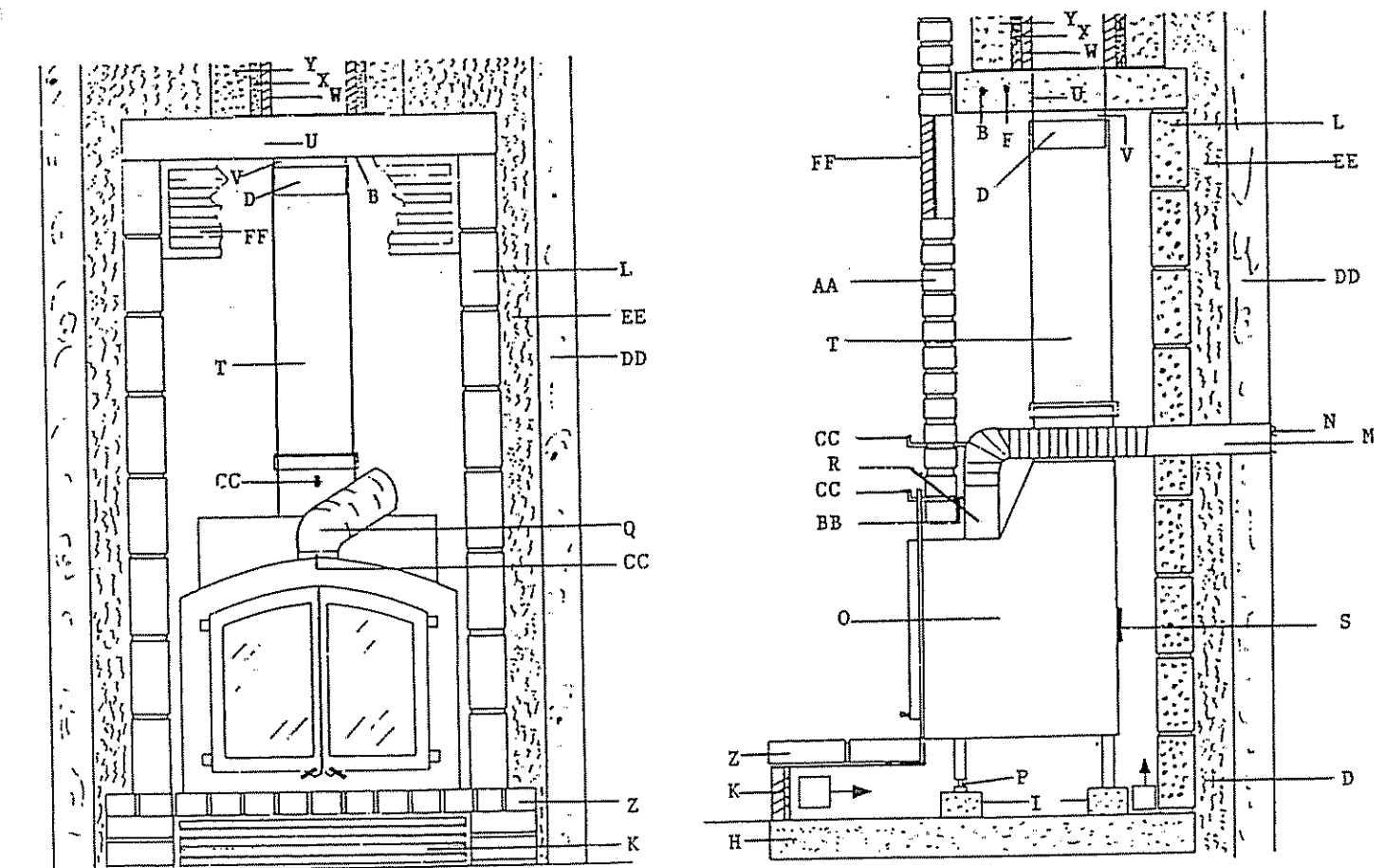

Fig. 5

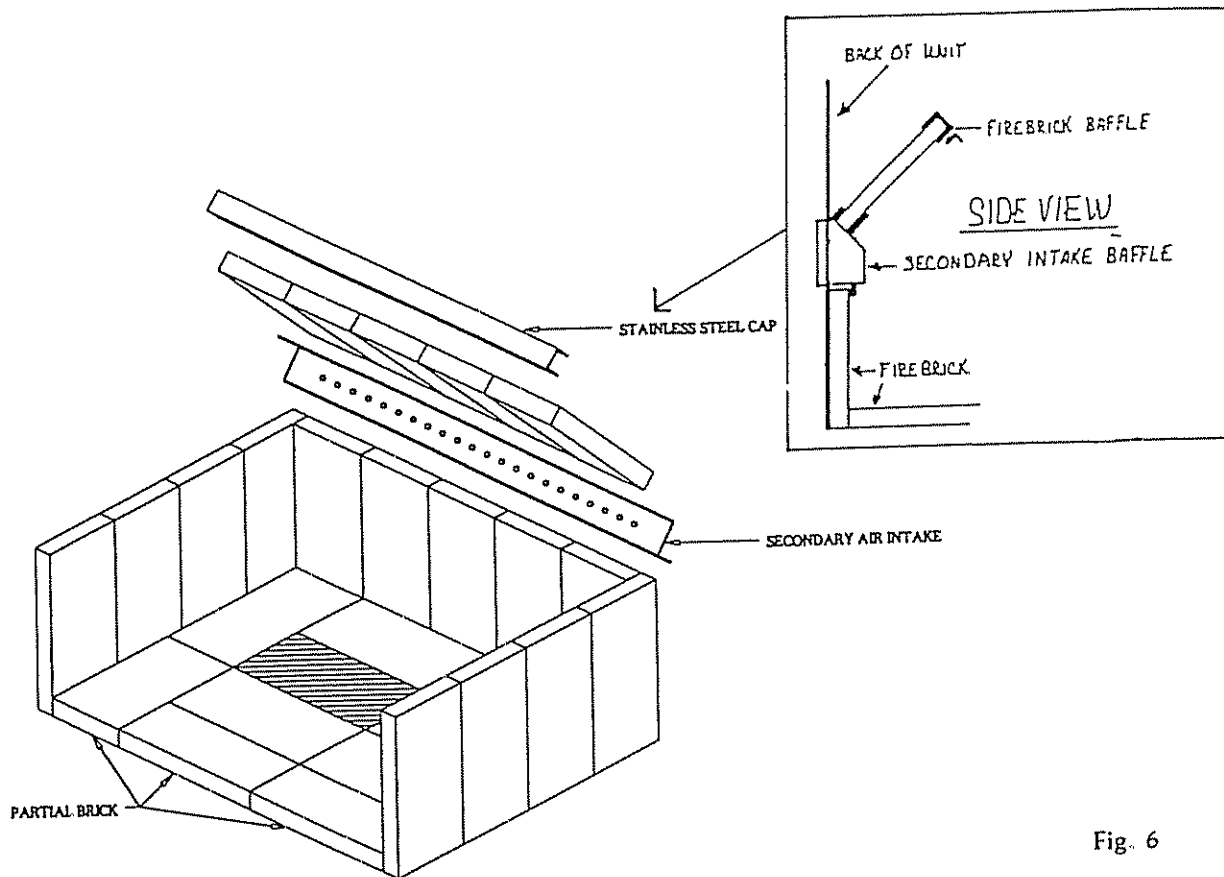

Fig. 6

 ASH CHUTE LOCATION / 231 BRICK LAYOUT

Slab Support Re-rod Requirements

2 Story, Basement Fireplace
Tensile Steel Bottom

10' Chimney 1 Story, First Floor Fireplace

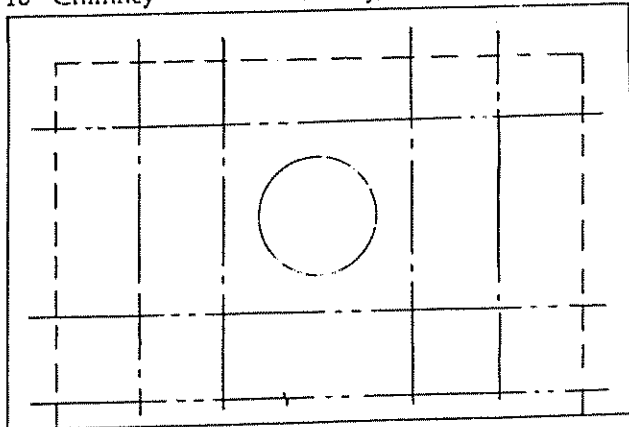

28' Chimney

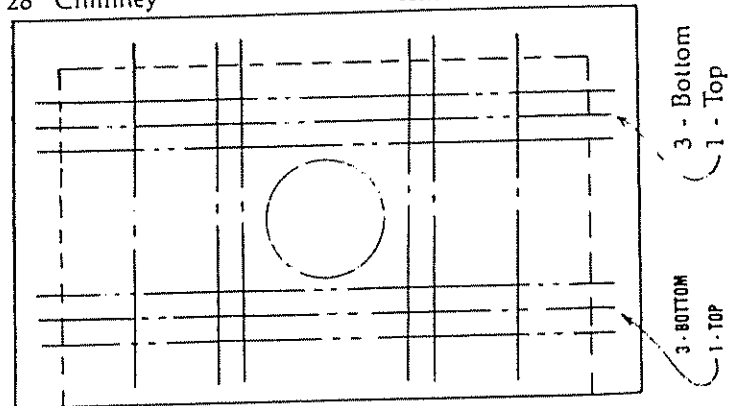

Compressive Steel #4

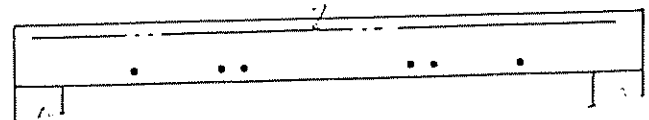

19' Chimney 1 Story, Basement Fireplace or 2 Story, First Floor Fireplace

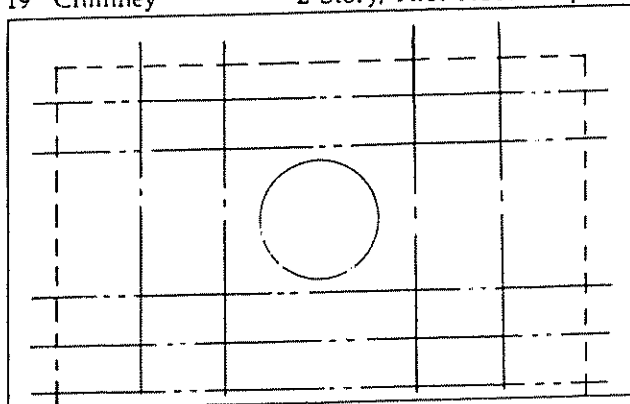

All Reinforcing $\frac{1}{2}$ \emptyset , #4

All Ends Bent and Anchored to Wall
Where Applicable

Fig. 7

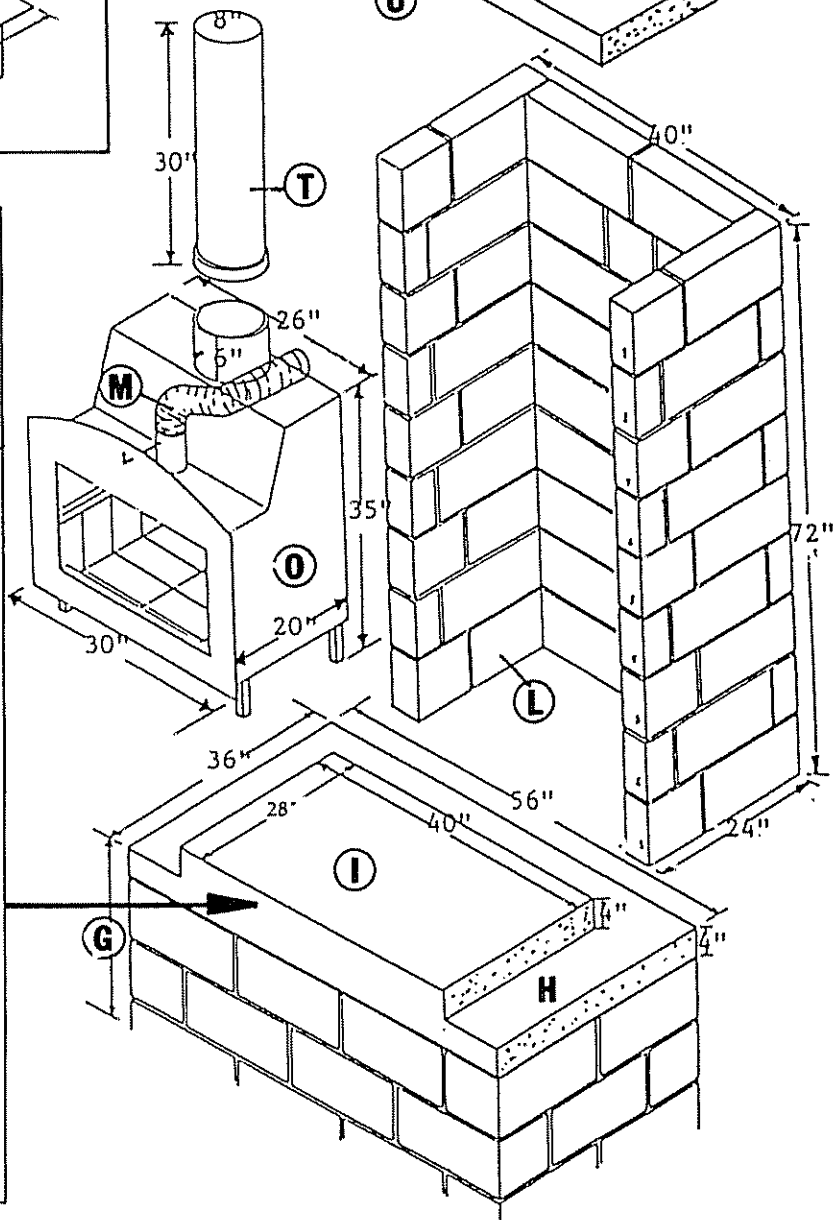
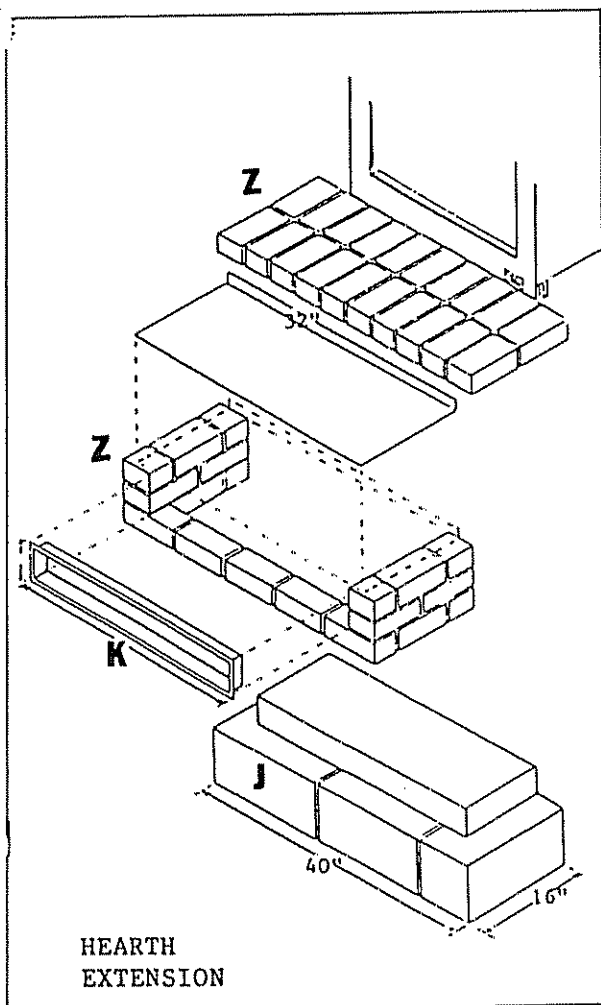
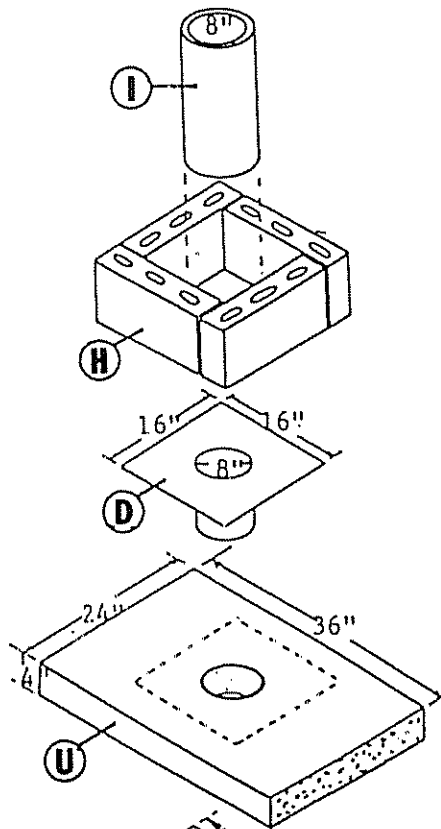
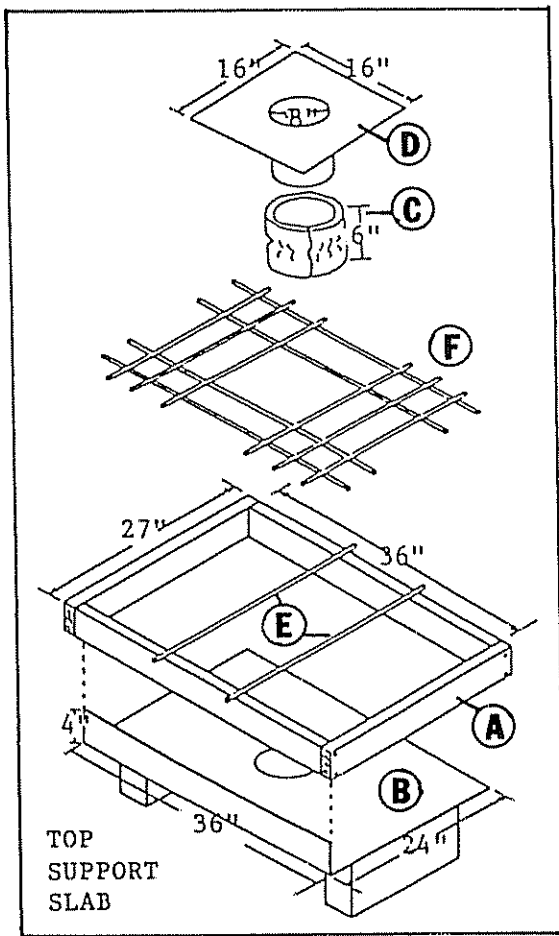

SAVE THESE INSTRUCTIONS!

Contact your dealer or the factory for any additional information you may need.

REPLACEMENT PARTS

- 1) 11" x 16 1/2" Glass
- 2) Damper Handles
- 3) Latch Handles
- 4) Door Felt
- 5) Door Rope-3/8"

AVAILABLE OPTIONS

- 1) Gold-plated or Black Doors
- 2) Chimney stack offset
- 3) Ash Chute
- 4) Outside Clean Out
- 5) Fan
- 6) Speed Control
- 7) Chamber Top Plate
- 8) Outside Air Vent
- 9) Brass Grills

Hussong Mfg. Co., Inc.

204 Industrial Park Drive

P.O. Box 577

Lakefield, MN 56150

507-662-6641

FAX: 507-662-6644