

The first name in fireplaces

6. ATTIC INSULATION SHIELD

An insulation shield should be installed when there is a possibility of insulation coming into contact with the factory built chimney system. The insulation shield is installed by positioning it over the vertical chimney section where it penetrates a firestop spacer. The firestop spacer will support the insulation shield. See Figure 12.

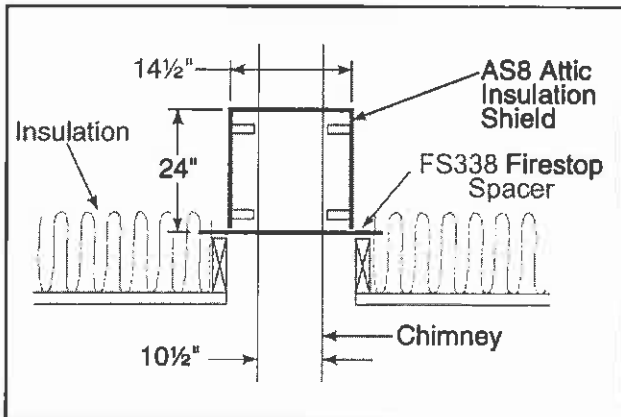

Figure 12 - Installing an Attic Insulation Shield

7. DOUBLE-CHECKING THE CHIMNEY ASSEMBLY

Continue assembling the chimney sections up through the firestop spacers as needed. While doing so, be aware of the height and unsupported chimney length limitations that are given on page 12 under "Chimney Requirements".

Check each section by pulling up slightly from the top to ensure proper engagement before installing the succeeding sections. If they have been connected correctly, they will not disengage when tested.

CAUTION:

Inner flue and outer liner sections cannot be disassembled once locked together. Plan ahead to ensure the proper installation height is achieved with the selected chimney components.

WARNING!

Maintain a minimum of 2" air clearance to all parts of the chimney system at all times! Failure to maintain this 2" air clearance will cause a structure fire.

8. SECURING THE CHIMNEY SYSTEM

When offsets and returns are joined to straight pipe sections, they must be locked into position with the screws provided (outer only), using the predrilled holes. To prevent gravity from pulling the chimney sections apart, the returns and the chimney stabilizers have straps for securing these parts to joists or rafters. See Figure 13.

Note: You must provide support for the pipe during construction and check to be sure inadvertent loading has not dislodged the chimney section from the fireplace or at any chimney joint.

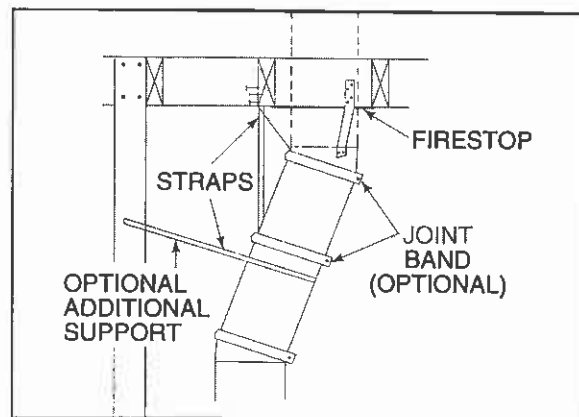

Figure 13 - Offset/Return with Stabilizer

WARNING!

When chimney sections exceeding six feet in length are installed between an offset and return, structural support must be provided to reduce off-center loading and prevent chimney sections from separating at the chimney joints.

9. MARKING THE EXIT POINT OF THE ROOF

Locate the point where the chimney will exit the roof by plumbing down to the center of the chimney. Drive a nail up through the roof to mark the center. See Figure 14.

10. CUTTING OUT THE HOLE IN THE ROOF

Measure to either side of the nail and mark the 14½" x 14½" opening required. This is measured on the horizontal; actual length may be larger depending on the pitch of the roof. Cut out and frame the opening. See Chapter 25 of the Uniform Building Code for roof framing details.

Be sure to maintain a 2" minimum air space between the chimney section and the roof.

11. ASSEMBLING THE CHIMNEY SECTIONS THROUGH THE ROOF

Continue to add chimney sections through the roof opening, maintaining at least a 2" air space.

12. INSTALLING THE ROOF FLASHING

If a roof flashing is to be used, install the roof flashing appropriate to the roof pitch and install a round termination cap following the instructions shipped with the cap.

For chase installations you can use a round termination cap (TR344), a round telescoping termination cap (TR342) or a square termination cap (ST375, TS345, TS345P). A chase installation must use a chase top. Chase tops are available from your Heatilator distributor. See page 22 for building a chase.

13. INSTALLING THE OUTSIDE AIR KIT

The outside air kit is supplied as an optional feature with this fireplace and its use is highly recommended to minimize the effects of negative pressure within the structure. It is recommended to utilize the shortest duct run to optimize the performance of the outside air kit. The outside air kit inlet thimble should be positioned at least four feet above the ground level, in a manner that will not allow snow, leaves, etc. to block the inlet.

The outside air kit is installed on the left hand side of the fireplace. Remove the cover plate from the side of the fireplace assembly where the air kit is to be installed. See Figure 15 for handle location/operation.

14. INSTALLING THE CHIMNEY AIR KIT (REQUIRED IN CANADA)

When installing the chimney air kit, follow the instructions provided with this accessory.

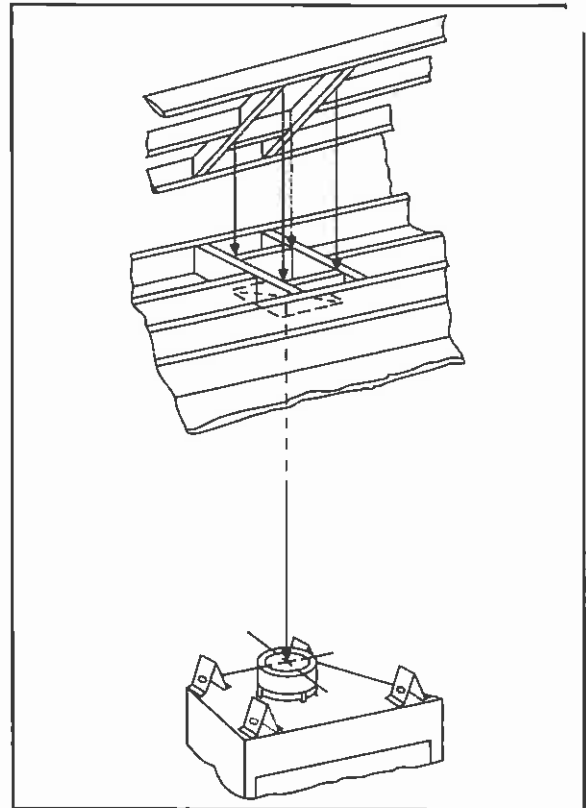

Figure 14 - Ceiling/Attic Construction

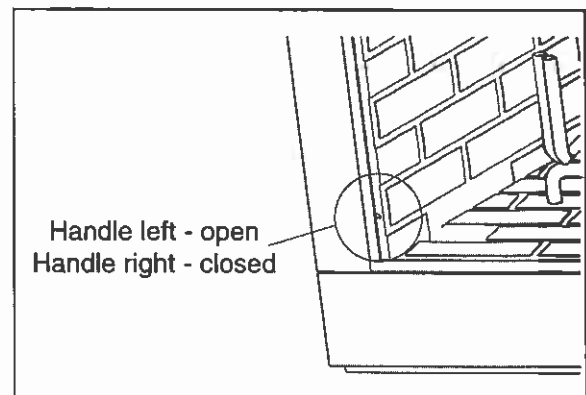

Figure 15 - Air Kit Handle Location

5. COMPLETION OF THE ENCLOSURE

Complete the fireplace enclosure, allowing space for outside air ducts and gas piping if desired. Electrical wiring should not come in contact with the fireplace. **A minimum clearance of ¾" must be maintained between the fireplace sides and the enclosure as well as the fireplace back and the enclosure.** See pages 10-12 for framing details.

Note: Use only a noncombustible material to finish the face of the fireplace below the level of the front standoffs. A noncombustible material such as USG MICORE CV230 Mineral Fiber Board, or USG DUROCK Cement Board is recommended for this purpose.

CAUTION:

When using a gas log set, the fireplace damper must be set in the fully open position. This ensures proper venting of combustion products.

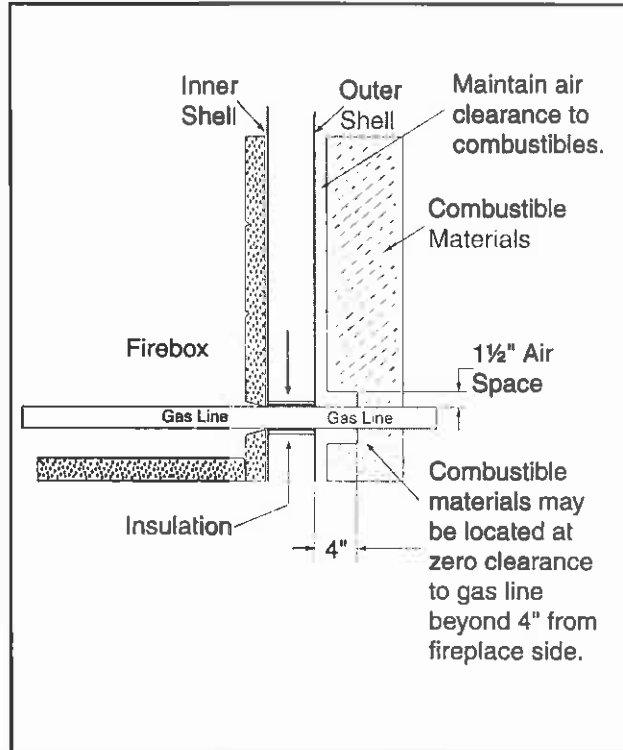

Figure 16 - Air Clearance Around Gas Line

16. GAS LOG/LIGHTER PROVISIONS

Knockouts are provided on both sides of the fireplace to allow for connection of a certified gas log lighter or a decorative gas appliance with a maximum input of 100,000 BTU/hour, incorporating an automatic gas shutoff device and complying with the **Standard for Decorative Gas Appliances for Installation in Vented Fireplaces, ANSI Z21.60.** The decorative gas appliance should be installed in accordance with the **National Fuel Gas Code, ANSI Z223.1-1980.** The side refractories are designed to allow ½" iron pipe to pass through. Use a noncombustible sealant to seal any opening between the gas pipe and refractory on the inside. Repack the insulation removed to seal around the gas pipe where it exits the side of the fireplace. A minimum 1½" air clearance must be provided around the ½" iron pipe for a minimum of 4 inches beyond the fireplace. See Figure 16.

CLEARANCES!

A minimum ¾" air clearance must be maintained at the back and sides of the fireplace assembly.

Chimney sections at any level require a 2" minimum air space clearance between the framing and chimney section.

WARNING!

This fireplace was not tested by the fireplace manufacturer for use with an unvented gas log heater. To reduce risk of injury, do not install an unvented gas log heater in this fireplace unless it has been specifically tested and listed by Underwriter's Laboratories Inc. for use in this specific model fireplace. Unless the unvented gas log heater is tested and listed for use in this factory built fireplace, a fire hazard may be created that can result in a structure fire.

The first name in fireplaces

17. HEARTH EXTENSION

A hearth extension must be installed with all fireplaces to protect the combustible floor in front of the fireplace from both radiant heat and sparks.

The construction of, and materials used for a hearth extension are shown in Figures 17 and 18. A hearth extension of this construction may be covered with any noncombustible decorative material and may have a maximum thickness as per the illustration. Seal gaps between the hearth extension and the front of the fireplace with a bead of noncombustible sealant.

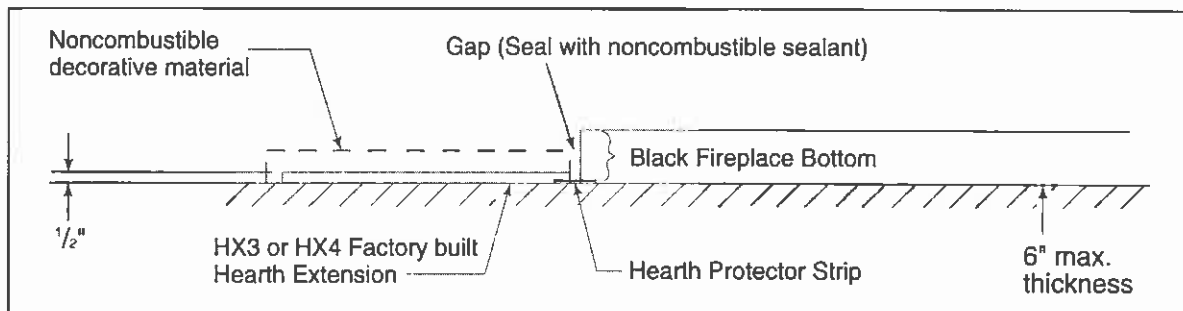

Figure 17 - Factory Hearth Extension

Field constructed hearth extensions should be constructed in accordance with the instructions in Figure 18. The field constructed hearth extension must be constructed from 1/2" MICORE CV230, or a material with an equivalent insulation value.

EXAMPLES OF INSULATION		
	MINIMUM REQUIRED THICKNESS	K VALUE
USG MICORE CV230	1/2"	0.43

(THERMAL CONDUCTIVITY) "K" = BTU in./hr. ft. °F

TO SUBSTITUTE ALTERNATE INSULATION MATERIAL, YOU NEED TO KNOW THE "K" FACTOR FOR THAT MATERIAL. TO CALCULATE THE REQUIRED THICKNESS FOR THE ALTERNATE MATERIAL USE THE FOLLOWING FORMULA:

$$\frac{K \text{ ALT.}}{43} \times .5 = \text{THICKNESS OF ALTERNATE MAT. (INCHES)}$$

EXAMPLE: "K" OF BRICK = 5

$$\frac{5}{43} \times .5 = 5.81 \text{ IN. OF BRICK.}$$

CAT. #	A	B
A36R	52"	16"
A42R	66"	20"

Figure 18 - Field Constructed Hearth Extension

WARNING!

Hearth extensions are to be installed only as illustrated to prevent high temperatures from occurring on concealed combustible materials. Hearth sealing strips prevent burning or hot particles from inadvertently falling directly on combustible surfaces in the event the building should settle and disturb the original construction.

3. POSITION THE HEARTH EXTENSION

Position and secure the hearth extension over the protective metal strips that have been placed partially under the fireplace front. These strips should be protruding approximately 2" from under the fireplace front and 2" on both sides of the fireplace opening. **Seal the crack between the hearth extension and fireplace with a bead of noncombustible sealant.** See Figure 19. Apply a noncombustible finishing material of your choice to the hearth extension.

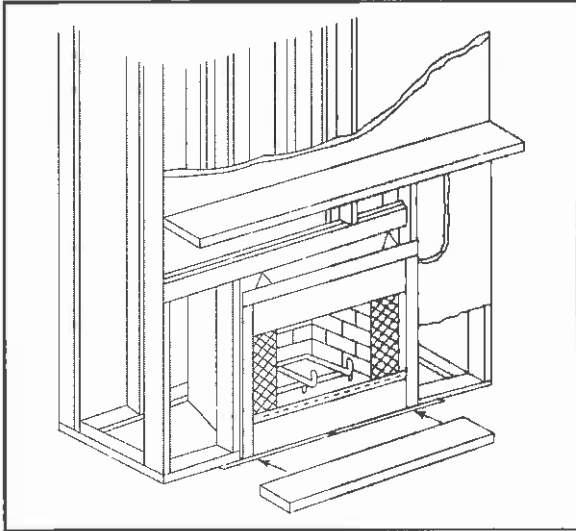

Figure 19 - Position the Hearth Extension

19. FINISHING MATERIAL

Do not install combustible materials over the black face of the fireplace! This poses a safety hazard and may start a fire. You may only use noncombustible material over the black face of the fireplace.

- a. **Combustible Material**
Material which is made of or surfaced with wood, compressed paper, plant fibers, plastics, or any material capable of igniting and burning, whether flame proofed or not, plastered or unplastered.
- b. **Noncombustible Material**
Material which will not ignite and burn. Such materials are those consisting entirely of steel, iron, brick, tile, concrete, slate, glass or plasters, or any combination thereof.
- c. **Noncombustible Sealant Material**
Sealants which will not ignite and burn; General Electric RTV103 Black (or equivalent), Rutland, Inc. Fireplace Mortar #63 (or equivalent).
After completing the framing and applying the facing material (dry wall) over the framing, a ½" wide (maximum) bead of noncombustible sealant must be used to close off any gaps at the top and sides between the fireplace and facing to prevent cold air leaks.
Only noncombustible materials may be used to cover the black metal fireplace front.

20. MANTEL

A combustible mantel may be positioned no lower than 12" above the top of the fireplace opening. The combustible mantel may have a maximum depth of 12". Combustible trim pieces that project no more than 1½" from the face of the fireplace can be placed no closer than 6" from the top of the fireplace opening. Combustible trim must not cover the black metal surfaces of the fireplace. This mantel clearance is in accordance with Section 7-3.3.3 of ANSI/NFPA211.

21. GLASS DOORS

This fireplace has been tested and listed for use with doors as specified in Section C, "System Components". Please refer to the manual packed with each set of doors for installation instructions.

G. CONSTRUCTING A CHASE

A chase is a vertical boxlike enclosure built around the chimney and fireplace. A chase may be constructed for the fireplace and chimney or for the chimney only. It is most commonly constructed on an outside wall.

In cold climates, it is recommended that the chase floor be insulated using batt type insulation between the floor joists.

Three examples of chase applications are shown in Figure 20.

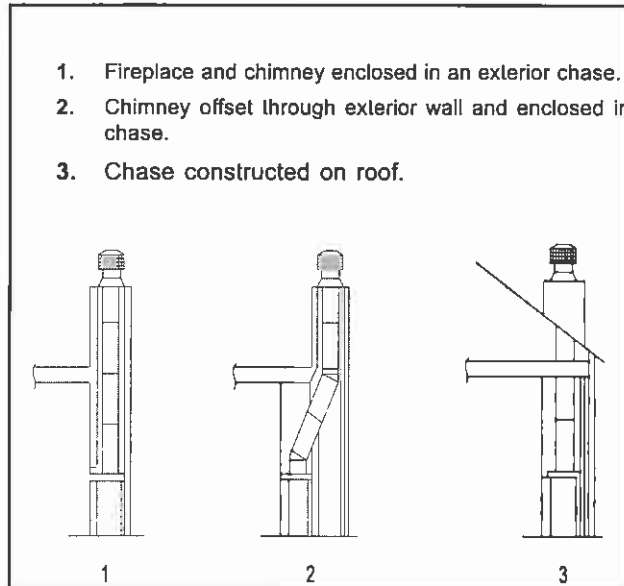

Figure 20 - Chase Constructions

1. MATERIALS

- a. The chase is constructed using framing materials much the same as the walls in your home. A variety of materials may be used including brick, stone, veneer brick, or standard siding materials.
- b. In constructing the chase, several factors must be considered:
 - 1) Maintain a 2" air space around the chimney.
 - 2) The chase top must be constructed of noncombustible material.
 - 3) In cold climates, a firestop spacer should be installed in an insulated false ceiling at the 8' level above the fireplace assembly. This reduces heat loss through the chase.
 - 4) In cold climates, the walls of the chase should be insulated to the level of the false ceiling as shown in Figure 21. This will help reduce heat loss from the home around the fireplace.

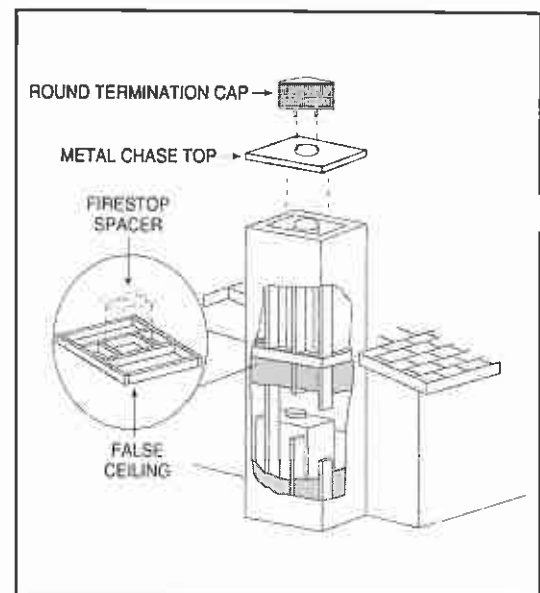

Figure 21 - Chase Assembly

CHASE TOP

Construct a chase of desired materials maintaining a minimum 2" air space around the chimney.

3. TERMINATION CAP

- a. Install the chimney sections up through the chase enclosure. When using a TR344 round termination cap, the uppermost top section of pipe must extend 6" above the top of the chase collar to allow installation of the storm collar and termination cap. See Figure 22.
- b. For installations utilizing a TR342 telescoping round termination cap, the uppermost chimney section must be below the top of the chase top, but not more than 14½" below the top of the chase top flashing collar. See Figure 23.

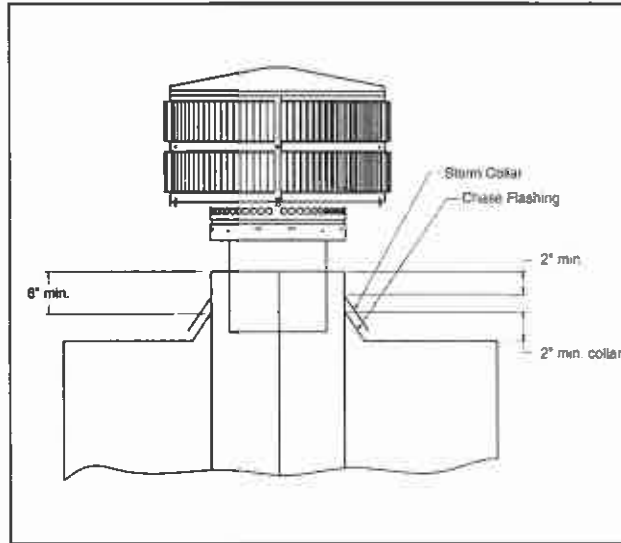

Figure 22 - Installing a TR344 Round Termination Cap

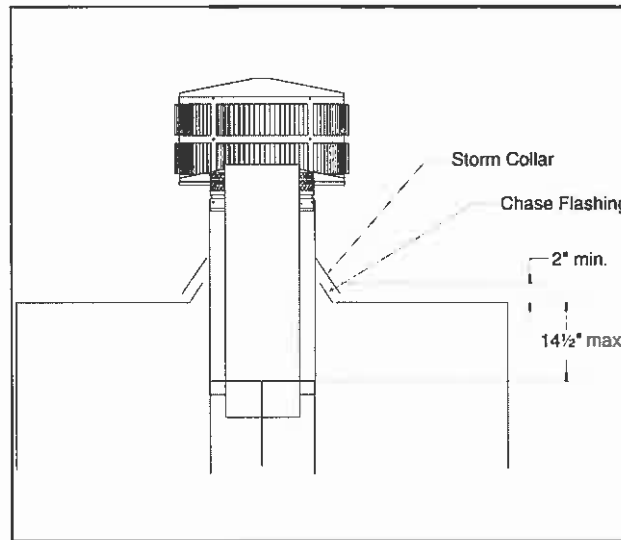

Figure 23 - Installing a TR342 Round Telescoping Termination Cap

- c. For installations utilizing an ST375 square termination cap the last chimney section must not be more than 4½" below the chase top. See Figure 24.
- d. For installation utilizing a TS345/TS345P Square Termination Cap, the uppermost chimney section must not be more than 3" below the chase top. See Figure 25.
- e. Attach the chase top (CT35) to the top of the chase.
- f. Attach the chase top to the top of the chase.
- g. Install the termination cap, following the instructions provided with it.

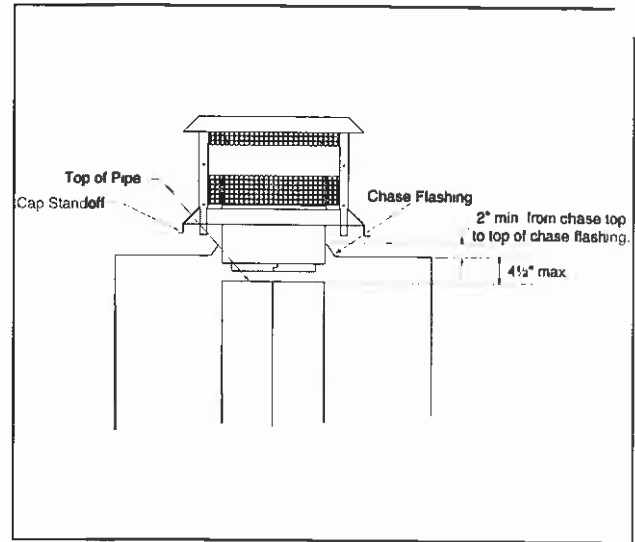

Figure 24 - Installing an ST375 Square Termination Cap

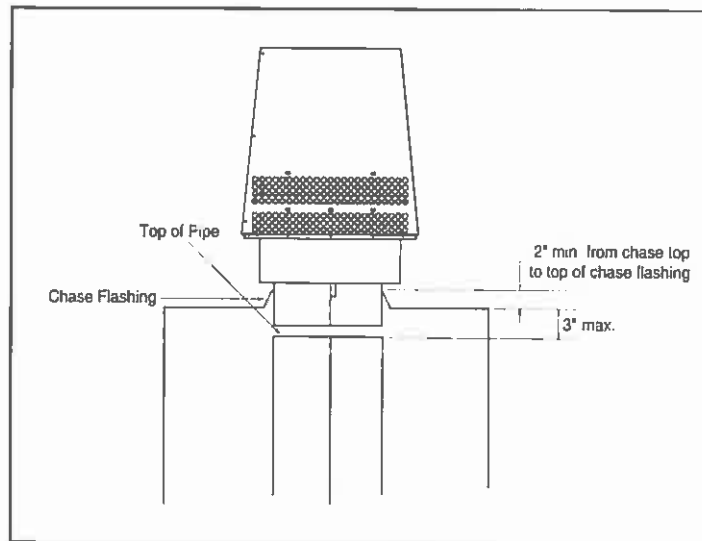

Figure 25 - Installing a TS345/TS345P Square Termination Cap

WARNING!

Never install a single wall slip section or smoke-pipe in a chase structure. The higher temperature of this single wall pipe may radiate sufficient heat to combustible chase materials to cause a fire.

WARNING!

Detailed instructions for installation of the chase top, storm collar and termination cap are packaged with these parts. To avoid danger of fire, all instructions must be strictly followed, including the provision of air space clearance between chimney system and enclosure. To protect against the effects of corrosion on those parts exposed to the weather, we recommend that the chase top and termination cap be painted with a rust-resistant paint.