

TRADITIONS™
BY LENNOX HEARTH PRODUCTS

INSTALLATION AND OPERATION MANUAL

**EPA CERTIFIED
CATALYTIC
FREESTANDING
WOODSTOVE**



RETAIN THESE
INSTRUCTIONS
FOR FUTURE
REFERENCE

MODEL T150C

**THIS APPLIANCE MUST BE INSTALLED BY A QUALIFIED TECHNICIAN.
READ MANUAL THOROUGHLY BEFORE INSTALLATION.**

Tested &
Listed By  Beaverton
Oregon USA
OMNI - Test Laboratories, Inc.

P/N 775008M, Rev. P, 04/02

IMPORTANT WARNINGS

CAUTION: PLEASE READ THIS ENTIRE MANUAL BEFORE YOU INSTALL AND USE YOUR NEW ROOM HEATER. FOR YOUR SAFETY, FOLLOW THE INSTALLATION, OPERATION AND MAINTENANCE INSTRUCTIONS EXACTLY, WITHOUT DEVIATION. FAILURE TO FOLLOW THESE INSTRUCTIONS MAY RESULT IN PROPERTY DAMAGE, BODILY INJURY, OR EVEN DEATH. IF THIS APPLIANCE IS NOT PROPERLY INSTALLED, A HOUSE FIRE MAY RESULT. CONTACT YOUR LOCAL BUILDING OR FIRE OFFICIALS ABOUT RESTRICTIONS AND INSTALLATION INSPECTION REQUIREMENTS IN YOUR AREA.

1. If utilizing an older chimney, it must be inspected for adequate serviceability. Refer to the heading *Chimney Inspection* on page 8 of this manual.
2. The minimum clearances must be maintained for all combustible surfaces and materials including; furniture, carpet, drapes, clothing, wood, papers, etc. Do not store firewood within this clearance space. Failure to maintain clearances to all combustibles may result in a house fire.
3. This appliance requires non-combustible floor protection as outlined in this manual (see *Floor Protection* on page 5 for additional information).
4. Minimum ceiling height must be 7 feet (213 cm) (measured from base of appliance to ceiling).
5. **DO NOT CONNECT THIS UNIT TO A CHIMNEY FLUE CONNECTED TO ANOTHER APPLIANCE.**
6. Do not connect this appliance to air ducts or any air distribution system.
7. **PREVENT CREOSOTE FIRE:** Inspect and clean chimney frequently. Under certain conditions of use, creosote buildup may occur rapidly. Inspect chimney connector and chimney twice monthly and clean if necessary. Using green or inadequately seasoned wood can greatly increase creosote buildup. Use dry wood to minimize creosote buildup.
8. **USE SOLID WOOD FUEL ONLY:** This appliance is approved for burning dry seasoned natural wood only. **CAUTION: BURN UNTREATED WOOD ONLY. OTHER MATERIALS SUCH AS WOOD PRESERVATIVES, METAL FOILS, COAL, PLASTIC, GARBAGE, SULFUR OR OIL MAY DAMAGE THE CATALYST. DO NOT BURN GARBAGE OR FLAMMABLE FLUIDS SUCH AS GASOLINE, NAPHTHA OR ENGINE OIL.**
9. Never use gasoline, gasoline-type lantern fuel, kerosene, charcoal lighter fluid, or similar liquids to start or "freshen up" a fire in this heater. Keep all such liquids well away from the heater while it is in use.
10. **DO NOT OVERFIRE:** If heater or chimney connector glows, you are overfiring. Overfiring this appliance could cause a house fire. Overfiring is a condition where the appliance is operated at temperatures above its design capabilities. Overfiring can be caused by improper installation, improper operation, lack of maintenance or improper fuel usage. Damage caused from overfiring is NOT covered under the manufacturer's limited warranty.
11. **NEVER LEAVE AN UNATTENDED STOVE BURNING ON HIGH.** Operation of the stove with the primary air control at its highest burn rate setting for extended periods can cause dangerous overfiring conditions. The primary air control should only be positioned at the highest setting during start-up procedures and for short durations. When leaving the stove unattended ensure that the primary air control is set to the low or medium low range.
12. Use a metal container with a tight fitting lid to dispose of ashes.
13. **IN THE EVENT OF A COMPONENT FAILURE, USE ONLY COMPONENTS PROVIDED BY THE MANUFACTURER AS REPLACEMENT PARTS.**
14. Burning any kind of fuel uses oxygen from the dwelling. Be sure that you allow an adequate source of fresh air into the room where the stove is operating (see *Ventilation* on page 6).
15. **CAUTION: HOT WHILE IN OPERATION.** An appliance hot enough to warm your home can severely burn anyone touching it. Keep children, clothing and furniture away. Contact may cause skin burns. Do not let children touch the appliance. Train them to stay a safe distance from the unit.
16. Do not operate this appliance without the firebox baffle brick properly installed.
17. Build fires directly upon the brick hearth inside the stove. Do not use grates, irons or any other method to elevate the fire.
18. **SAVE THESE INSTRUCTIONS.**
19. See the listing label located on the back of stove (or see Safety/Listing Label on page 26).

TABLE OF CONTENTS

Important Warnings	2
Testing/Listing, EPA, Using this Manual	3
Planning Your Installation	4-7
Installation	7-11
Product Features and Controls	11
Care and Operation.....	12
Recommended Fuel.....	16
Maintenance.....	17-19
Troubleshooting	20-21
Specifications	22
Replacement Parts List.....	23-24
Optional Accessories	25
Safety/Listing Label.....	26
EPA Label	27
Ownership Records	28

TESTING/LISTING

Model T150C has been tested to UL Standards 1482, ULC-S627 for installation into residential applications. The listing laboratory is OMNI Environmental Services, Beaverton, Oregon, Report #030-S-01-2.

EPA CERTIFICATION

This stove has been tested to rigorous emissions standard, and has been certified by the Environmental Protection Agency.

PACKAGING LIST

This appliance is packaged with an accessory package, which contains the following:

- One - Installation and operation instructions manual.
- One - Warranty.
- One - Insulation pad and strips (If optional marble is used: Place pad under top marble and strips under ash lip marble).

USING THIS MANUAL

Please read and carefully follow all of the instructions found in this manual. Please pay special attention to the safety instructions provided in this manual. The Homeowner's Care and Operation Instructions included here will assure you have many years of dependable and enjoyable service from your appliance.

CONGRATULATIONS ON THE PURCHASE OF YOUR NEW WOODSTOVE MANUFACTURED BY LENNOX HEARTH PRODUCTS.

When you purchased your new woodstove, you joined the ranks of thousands of concerned individuals whose answer to their home heating needs reflects their concern for aesthetics, efficiency and our environment. We extend our continued support to help you achieve the maximum benefit and enjoyment available from your new woodstove.

It is our goal at Lennox Hearth Products to provide you, our valued customer, with an appliance that will ensure you years of trouble free warmth and pleasure.

Thank you for selecting a Lennox Hearth Products stove as the answer to your home heating needs.

Sincerely,
All of us at Lennox Hearth Products

PLANNING YOUR INSTALLATION

QUESTIONS TO ASK LOCAL BUILDING OFFICIAL

A correct installation is critical and imperative for reducing fire hazards and perilous conditions that can arise when wood burning appliances are improperly installed. The installer must follow all of the manufacturers' instructions.

The installation of a wood burning appliance must conform to local codes and applicable state and federal requirements. Familiarity with these requirements before installation is essential. Important considerations to discuss with local building officials include:

1. Applicable codes (i.e. Uniform Mechanical Code, State or Regional Codes)
Electrical codes: Optional Blower Assemblies have a flexible electrical cord that must be electrically grounded per local codes or per electrical codes:
In USA, NEC, ANSI/NFPA 70-1987
In Canada, CSA C22.1

WARNING: ELECTRICAL GROUNDING INSTRUCTIONS: THIS APPLIANCE IS EQUIPPED WITH A THREE-PRONG (GROUNDING) PLUG FOR YOUR PROTECTION AGAINST SHOCK HAZARD AND SHOULD BE PLUGGED DIRECTLY INTO A PROPERLY GROUNDED THREE-PRONG RECEPTACLE. DO NOT CUT OR REMOVE THE GROUNDING PRONG FROM THIS PLUG. DO NOT ROUTE POWER CORD UNDER OR IN FRONT OF APPLIANCE.

2. Local amendments?
3. Is a permit required - cost? (You may wish to contact your insurance company to ask if they require this.)
4. Rooms where the installation is not allowed?

SMOKE DETECTORS

Since there are always several potential sources of fire in any home, we recommend installing smoke detectors. If possible, install the smoke detector in a hallway adjacent to the room (to reduce the possibility of occasional false activation from the heat produced by the stove). If your local code requires a smoke detector be installed within the same room, you must follow the requirements of your local code. Check with your local building department for requirements in your area.

NOTE – This appliance is NOT approved for installation into a Manufactured (Mobile) Home in Canada or the US.

PLANNING YOUR INSTALLATION

FLOOR PROTECTION

This appliance requires non-combustible floor protection designed for solid fuel burning appliances having a thermal conductivity of $k = .84$ BTU in/ft or equivalent. If the floor protection is to be stone, tile, brick, etc., it must be mortared or grouted to form a continuous non-combustible surface (See *Using Alternate Material As Floor Protector* below). If a chimney connector extends horizontally over the floor, protection must cover the floor under the connector and at least 2" (51 mm) to either side.

The floor protection must extend completely beneath the stove and to the front, sides, and rear as indicated:

USA REQUIREMENTS

- 16" min. to the front of the fuel door glass
- 8" min. beyond the sides of the fuel door opening
- 6" min. to the back of the stove body

CANADA REQUIREMENTS

- 18" (457 mm) min. to the front of the fuel door glass
- 8" (203 mm) min. beyond the sides of the stove body
- 8" (203 mm) min. to the back of the stove body

STANDARD PARALLEL HEARTH PAD SHOWN

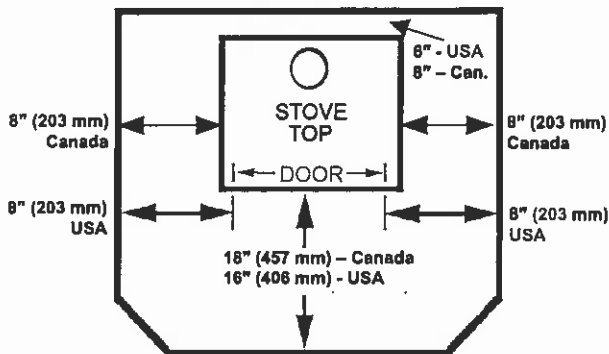

USING ALTERNATE MATERIAL AS FLOOR PROTECTOR

The alternate material used as a floor protector must be constructed of a durable noncombustible material having an equal or better insulating value (lower k value) of $k = .84$ BTU/IN FT² HR °F or a thermal resistance that equals or exceeds $r = 1.19$ HR °F FT² IN/BTU. With these values, determine the minimum thickness/material required using the formula and the table shown here (see chart - *Alternative Floor Protection Materials*).

Note: Any noncombustible material having a thickness of 1" (25.4 mm) whose k value is less than 1.28 or whose r value is more than .78 is acceptable. If the alternate material used has a higher k value or lower r value will require a greater thickness of the material used. In some cases, if the k value is less or the r value higher, a thinner material may be used.

Methods of determining floor protection equivalents:

To determine the thickness required for any material when either the k or r values are known:

T_M = Thickness of material in inches

K_M = K value of desired material

T_L = Minimum listed thickness

Example: Micore CV230 is to be used for the floor protection. How thick must this material be?

The following **formulas** give the means of determining minimum thickness required of alternate materials.

Using the **k formula**:

Desired Thickness of the alternate material = $\frac{k \text{ value of desired material (per inch)}}{k \text{ value of listed material (per inch)}} \times$ Minimum thickness of Listed Material

$$T_M \text{ (inches)} = \frac{K_M}{.84} \times T_L$$

$$T_M \text{ (inches)} = \frac{0.43^*}{.84} \times 1"$$

Answer using $k = 0.50 \times 1" = 0.50 = 1/2"$
3/8" thickness Micore will be required.

Using the **r formula**:

$$T_M \text{ (inches)} = \frac{1.19}{r_M} \times T_L$$

$$T_M \text{ (inches)} = \frac{1.19 \times 1"}{2.33^*}$$

Answer using $r = 0.50 \times 1" = .50 = 1/2"$
3/8" thickness Micore will be required.

At times it is important to know what combination of materials are acceptable for use as floor protection. The "R values" are used to determine acceptable combinations of materials because "R values" are additive where r and k values are not.

$$"R \text{ value}" = \frac{1}{k} = r \times \text{thickness of material used}$$

ALTERNATIVE FLOOR PROTECTION MATERIALS

	Values		Min. Thick
	k (per inch)	r (per inch)	T_L
Listed Material	.84	1.19	1"
Alternative Materials	Values		Min. Thick
	k (per inch)	r (per inch)	T_L
Wonderboard	1.92	0.56	2 1/2"
Common brick	5.00	0.20	6"
Cement mortar	5.00	0.20	6"
Ceramic tile	12.5	0.08	14 7/8"
Marble	11.0	0.09	13 1/8"
Micore CV230	0.43	2.33	1/2"
Ceraform 126	0.27	3.70	5/16"

Example: Given that the required "R value" for a suitable floor protector used must be equal to or greater than: "R" = $r \times T_L = 1.19 \times 1" = 1.19$.

Note: To convert inches to millimeters divide by .03937.

PLANNING YOUR INSTALLATION

SELECTING A LOCATION

The design of your home and where you place your stove will determine its value as a source of heat. A woodstove depends primarily on air circulation (convection) to disperse its heat, and therefore, a central location is often best. There are other practical considerations, which must be considered before a final selection of locations is made.

- ◆ Existing Chimneys
- ◆ Wood Storage
- ◆ Aesthetic Considerations
- ◆ Roof Design (Rafter Locations & Roof Pitch)
- ◆ Room Traffic
- ◆ Proximity to Combustibles
- ◆ Electrical Wiring

The installation of this stove will require some research. Once your options are determined, consult with your local building department who will be able to give you the necessary installation requirements for your area (is a building permit required, rooms where installation may not be allowed, etc.).

WARNING: CHECK ALL LOCAL BUILDING AND SAFETY CODES BEFORE INSTALLATION. THE INSTALLATION INSTRUCTIONS AND APPROPRIATE CODE REQUIREMENTS MUST BE FOLLOWED EXACTLY AND WITHOUT COMPROMISE. ALTERATIONS TO THE STOVE ARE NOT ALLOWED. DO NOT CONNECT THE STOVE TO A CHIMNEY SYSTEM SERVING ANOTHER STOVE, APPLIANCE, OR ANY AIR DISTRIBUTION DUCT. FAILURE TO FOLLOW THESE INSTRUCTIONS WILL VOID THE MANUFACTURERS WARRANTY.

If you plan to vent your stove into an existing masonry chimney, have it inspected by a local fire marshal or qualified installer. Remember that a stove's performance is heavily influenced by the chimney and its location on the roof. An oversized flue may not provide effective draw, and a flue liner may be required (see *Draft Requirements*, page 9). Consult your dealer or qualified installer before final selection is made.

This stove requires pre-installation work to be completed before installation can take place. This may include modification for flue and chimney.

COMBUSTIBLE WALL CLEARANCE

WARNING! IT IS VERY IMPORTANT THAT YOU OBSERVE THE MINIMUM CLEARANCES.

These are the listed clearances for this appliance which were determined in laboratory tests. Minimums are first established for the stove itself and increased or decreased based on how much heat is transferred by the pipe.

USA and CANADA RESIDENTIAL ONLY (not approved for manufactured (mobile) home) using single wall pipe connector to the top of the stove.

A	16" / 406 mm	D	11" / 279 mm
B	40" / 102 cm	E	30" / 762 mm
C	30" / 762 mm	F	20" / 508 mm

CORNER INSTALLATION

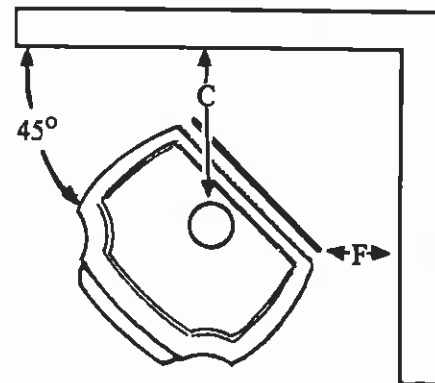

PARALLEL INSTALLATION

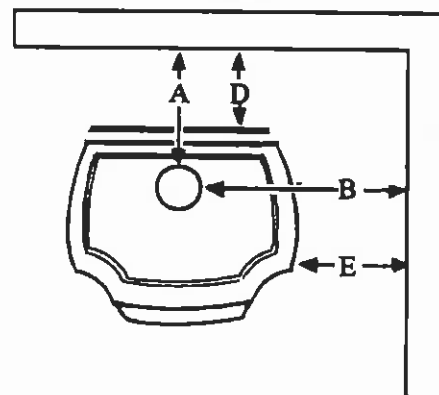

PLANNING YOUR INSTALLATION

REDUCED MASONRY STRUCTURE CLEARANCE (ALCOVE)

Your stove can be installed in a masonry structure with reduced clearances if the structure was built to National Building Code for fireplaces and chimneys (UBC 37).

The firebox of the masonry structure must be of adequate size to allow a minimum of 6" (152 mm) clearance to the sides and top of the stove and 2" (51 mm) clearance to the rear. All stove models must be installed on their original listed legs or base unless otherwise specified by OMNI Testing Laboratory.

The minimum venting requirement is a listed chimney liner that extends from the flue collar of the stove to the first tile liner of the chimney where it is sealed. All joints and connections must be made airtight to prevent leaking and downdrafts.

PROTECTED WALL CLEARANCE

Some local codes will allow reduced clearances when the stove is installed adjacent to a protected wall system. Your local building official must approve the variance. Normally, the protected wall system is defined as a non-combustible material with a minimum of 1" (25.4 mm) air space behind. Check your local building codes or with a qualified installer (Ref. NFPA 211).

VENTILATION REQUIREMENTS

THE FRESH AIR REQUIREMENTS OF THIS APPLIANCE MUST BE MET WITHIN THE SPACE WHERE IT WILL BE INSTALLED.

Ventilation is essential when using a solid fuel burning heater. The combustion process of this heater uses oxygen from inside the dwelling and it may be necessary to open a window or install a vent to provide make-up air into a dwelling that is well insulated (modern construction standards have resulted in homes that are highly energy-efficient and that allow little heat loss and air transfer). Other appliances in the dwelling also contribute to removing air from the dwelling (i.e. clothes dryers, exhaust fans, fireplaces, and other fuel burning appliances). If the available fresh air delivery in the dwelling is insufficient to support the demands of these appliances, problems can result (i.e. Excessive negative pressure can develop in the dwelling which will affect the rate at which this appliance can draft [See *Draft Requirements*, page 9], icing can develop in some environments).

INSTALLATION

INSTALLING (OPTIONAL) MARBLE ACCENTS

See *Optional Accessories*, page 25 for ordering information.

Important Note: Optional marble cannot be used if temperature probe is used.

Marble is a natural product and therefore each piece will have its own unique character. Marble can be scratched so care should be taken to avoid putting heavy or rough objects (trivet/steamers) on the surface. If the marble should become scratched, the scratch may be removed or diminished by polishing it with jewelers rouge (which can be purchased at many hardware stores). Do not install the marble before curing the paint.

The marble set consists of 2 pieces. A large piece that fits onto the stove top and a smaller piece that fits onto the ashlip (located below the fuel door).

Installation Steps:

Install the ceramic fiber blanket, gasket strips and marble set as follows:

Note: The fiber blanket and gasket strips are provided with the stove. The marble sets are optional accessories.

1. Using scissors cut the ceramic fiber blanket so that it fits into the recess of the stovetop.
2. Place the top marble piece onto the ceramic fiber blanket.
3. Place the gasket strips into the recess of the ashlip so that they are evenly spaced. This will slightly elevate the marble so that it is not making direct surface contact. Note: Insulation is not required in this area.
4. Place the ashlip marble onto gasket strips in ashlip recess.

INSTALLATION

TYPES OF CHIMNEYS

The chimney is a vital part of your stove installation. A properly built masonry chimney or a properly installed factory built chimney will assure a consistent draft under a variety of weather conditions (a smoking stove is usually caused by a chimney problem). The stove flue size is 6 inches (152 mm) diameter, which is approximately 28 square inches (711 square mm) minimum. The maximum flue size should be no more than (3)-three times the cross sectional area of the size of the stove flue collar. In this case, that would be no larger than a 10-inch (254 mm) diameter stack, or approximately 85 square inches (216 square cm) maximum.

All chimneys must be installed as specified by local building codes and according to the chimney manufacturer instructions (in the case of a factory built chimney). See the chimney manufacturer instructions for exact specifications. Factory built chimneys must comply with UL 103HT or ULC S629.

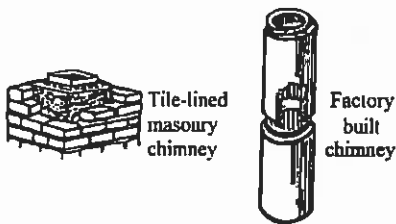

ACCEPTABLE CONNECTOR PIPE FOR INSTALLATIONS

For Standard Residential Clearances: Six 6 inch (152 mm) minimum, single wall, 25 gage minimum thickness, stove pipe is acceptable. Three (3) pre-drilled holes are provided in the flue collar for fastening the pipe securely to the stove. Use sheet metal screws to do this. Additional sections of single wall pipe should be fastened together with at least three (3) sheet metal screws each section. When connecting to the factory built ceiling support package, use the manufacturer's transition piece, usually called a dripless connector, to join single wall pipe to their factory built chimney section.

Minimum Flue Size: The required minimum diameter and area required for the flue size is (respectively) 6 inches / 152 mm diameter, which is approximately 28 square inches / 711 square mm. The maximum flue size should be no more than (3) three times the cross sectional area of the size of the 6 inches / 152 mm diameter flue collar. In this case, that would be no larger than a 10 inch (254 mm) diameter (area = approx. 85 sq. inches [216 sq. cm]).

Connection To A Factory Built Chimney: This space heater is to be connected to a factory-built chimney conforming to CAN / ULC – S629, Standard for 650°C Factory-Built Chimneys.

For Reduced Residential Clearances: Type L and listed double wall connector pipe is acceptable. Install any factory built brand of pipe according to the manufacturer's instructions.

Vapor Barrier at Chimney Penetration: Install all venting components per the Vent Manufacturers installation instructions. Ensure that there is an effective vapor barrier at the location where the chimney penetrates to the exterior of the structure. This can be accomplished by applying a non-hardening waterproof sealant to the following components:

- Around the chimney at the point where the storm collar will meet the chimney just above the Flashing.
- Along the vertical seam of the chimney pipe, where it is exposed to the weather.
- On each nail head on the flashing.
- Around the chimney at the point where the storm collar will meet the chimney just above the flashing.

Notes:

- On flat or tarred and graveled roofs, nail and seal the flat roof flashing to the roof on all sides with roofing compound.
- Do not put screws through the flashing into the chimney pipe.

CHIMNEY INSPECTION

Existing chimneys must be inspected before installing your stove. Consult your local building department for chimney code requirements. A masonry chimney must have a code approved liner. This liner must not have broken or missing pieces. Some non-code masonry chimneys may be brought up to code by being relined. (Consult your dealer or qualified chimney sweep).

Factory built chimneys should also be inspected, first for creosote deposits (which should be removed), and then for integrity of the stainless steel liner. Look for obvious bulges in the lining, which may indicate the need to replace that section (use a bright flashlight). Also, inspect the attic to see that the chimney has proper clearance to combustible framing members. For interior masonry chimneys and most factory-built chimneys, this must be a (2)-two inch (51 mm) air space clearance, which must not be filled with insulation or any other material. An exterior masonry chimney must have a (1) one-inch (25.4 mm) air space clearance.

INSTALLATION

CHIMNEY HEIGHT REQUIREMENTS

The chimney must extend 3 feet (914 mm) above the level of roof penetration and a minimum of 2 feet (610 mm) higher than any roof surface within 10 feet (305 cm) (see below). Check with your local building officials for any additional requirements for your area.

Due to prevailing winds, local terrain, adjacent tall trees, a hill, or ravine near the home, or adjacent structures, additional chimney height or a special chimney cap may be required to ensure optimum performance.

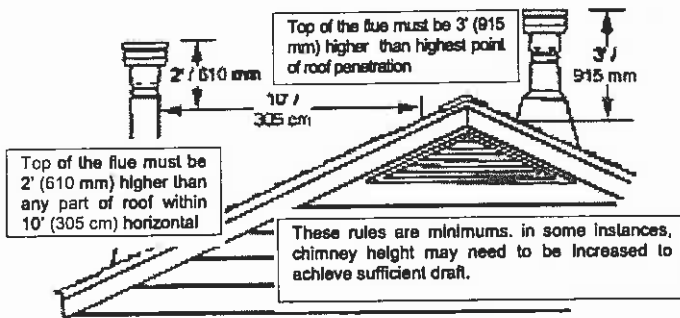

To achieve a stable draft, the total flue height required (from the appliance to termination) is 12 to 15 feet (366 to 457 cm) minimum.

DRAFT REQUIREMENTS

The appliance is merely one component of a larger system. The other equally important component is the venting system. This is necessary for achieving the required flow of combustion air to the fire chamber and for safely removing unwanted combustion byproducts from the appliance. If the venting system's design does not promote these ends, the system may not function properly. Poorly functioning venting systems may create performance problems as well as be a safety hazard (i.e. an oversized chimney may result in less than optimum performance. Installations into a large, masonry chimney may require a liner to improve performance). A draft test should read greater than .04' W.C. (inches water column) and less than .08" W.C.

American National Standards Institute ANSI/NFPA 211-92: A chimney or vent shall be so designed and constructed to develop a flow sufficient to completely remove all flue and vent gases to the outside atmosphere. The venting system shall satisfy the draft requirements of the connected appliance in accordance with the manufacturer instructions.

INSTALLATION

RESIDENTIAL INSTALLATION DIAGRAM

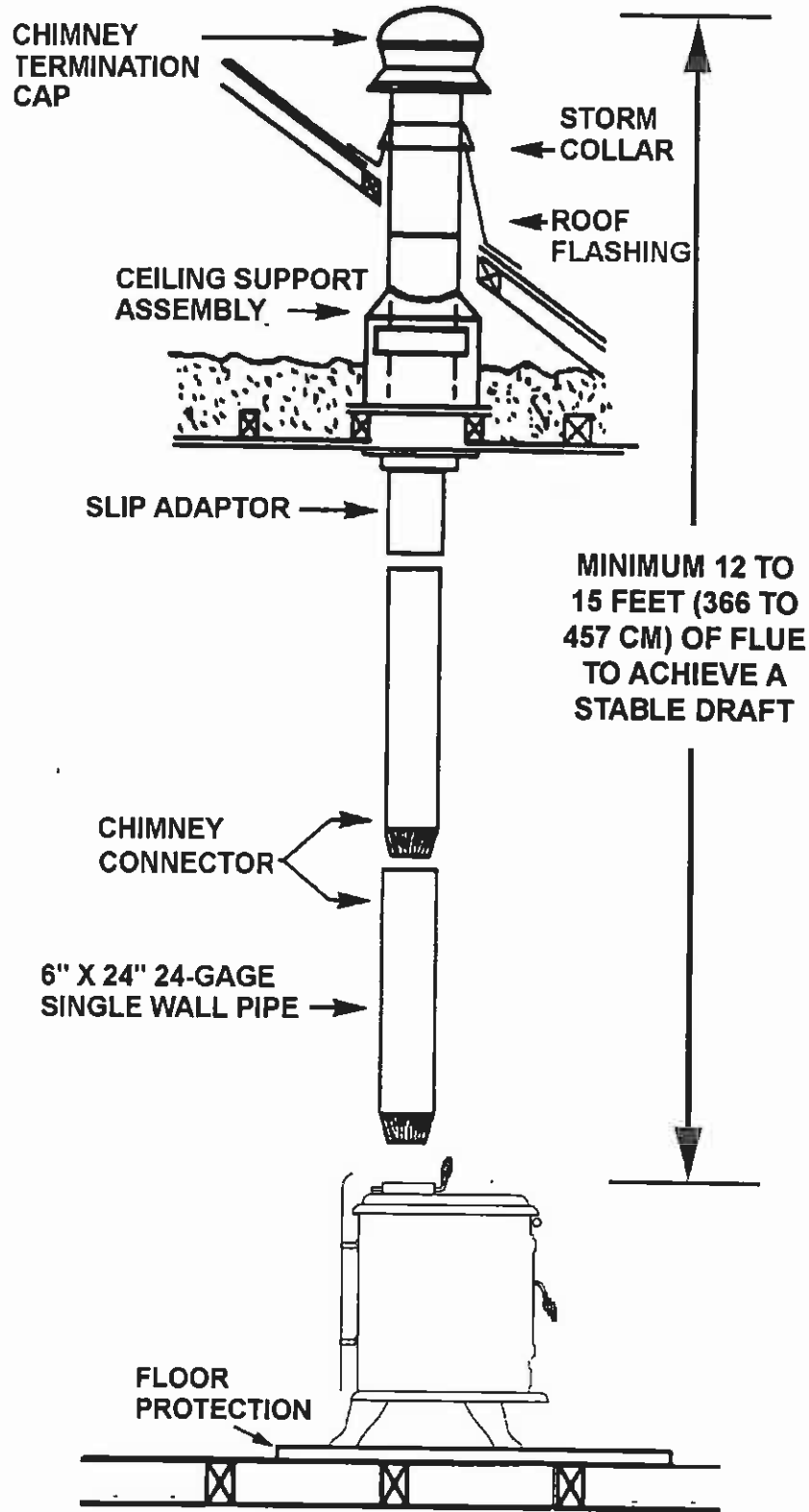

INSTALLATION Combustible Wall Chimney Connector Pass-Throughs

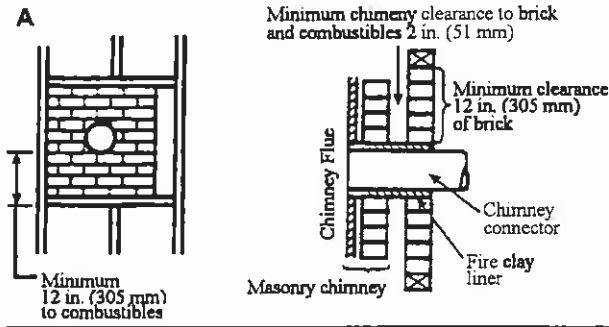

Method A. 12 inch (305 mm) Clearance to Combustible Wall Member: Using a minimum thickness 3.5 inch (90 mm) brick and a 5/8 inch (16 mm) minimum wall thickness clay liner, construct a wall pass-through. The clay liner must conform to ASTM C315 (Standard Specification for Clay Fire Linings) or its equivalent. Keep a minimum of 12 inches (305 mm) of brick masonry between the clay liner and wall combustibles. The clay liner shall run from the brick masonry outer surface to the inner surface of the chimney flue liner but not past the inner surface. Firmly grout or cement the clay liner in place to the chimney flue liner.

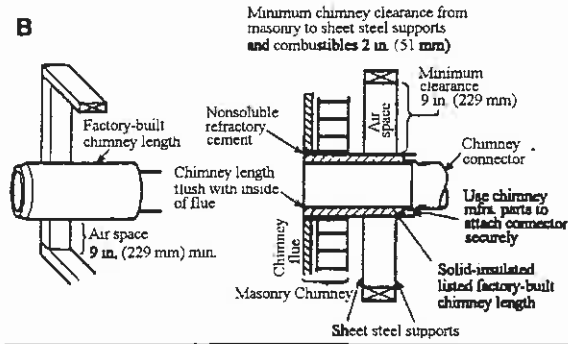

Method B. 9 inch (229 mm) Clearance to Combustible Wall Member: Using a 6 inch (152 mm) inside diameter, listed, factory-built Solid-Pak chimney section with insulation of 1 inch (25.4 mm) or more, build a wall pass-through with a minimum 9 inch air space between the outer wall of the chimney length and wall combustibles. Use sheet metal supports fastened securely to wall surfaces on all sides, to maintain the 9-inch (229 mm) air space. When fastening supports to chimney length, do not penetrate the chimney liner (the inside wall of the Solid-Pak chimney). The inner end of the Solid-Pak chimney section shall be flush with the inside of the masonry chimney flue, and sealed with a non-water soluble refractory cement. Use this cement to also seal to the brick masonry penetration.

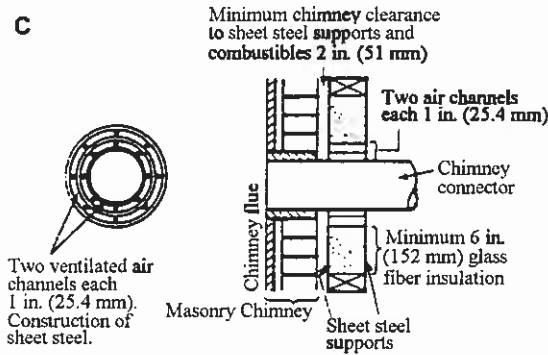

Method C. 6 inch (152 mm) Clearance to Combustible Wall Member: Starting with a minimum 24 gage (.024 inch [.61 mm]) 6-inch (152 mm) metal chimney connector, and a minimum 24 gage ventilated wall thimble which has two air channels of 1 inch (25.4 mm) each, construct a wall pass-through. There shall be a minimum 6 inch (152 mm) separation area containing fiber glass insulation, from the outer surface of the wall thimble to wall combustibles. Support the wall thimble, and cover its opening with a 24-gage minimum sheet metal support. Maintain the 6-Inch (152 mm) space. There should also be a support sized to fit and hold the metal chimney connector. See that the supports are fastened securely to wall surfaces on all sides. Make sure fasteners used to secure the metal chimney connector do not penetrate chimney flue liner.

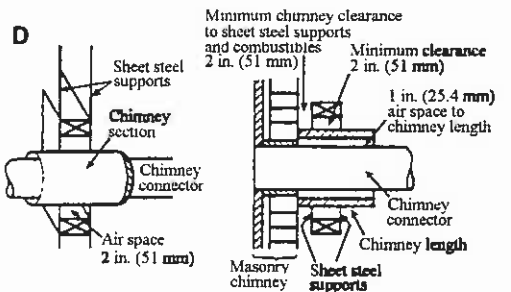

Method D. 2 inch (51 mm) Clearance to Combustible Wall Member: Start with a solid-pak listed factory built chimney section at least 12 inches (305mm) long, with insulation of 1 inch (25.4mm) or more, and an inside diameter of 8 inches (2 inches [51 mm] larger than the 6 inch [152 mm] chimney connector). Use this as a pass-through for a minimum 24-gage single wall steel chimney connector. Keep solid-pak section concentric with and spaced 1 inch (25.4 mm) off the chimney connector by way of sheet metal support plates at both ends of chimney section. Cover opening with and support chimney section on both sides with 24 gage minimum sheet metal supports. See that the supports are fastened securely to wall surfaces on all sides. Make sure fasteners used to secure chimney section do not penetrate chimney flue liner.

Note: Connectors to a masonry chimney, excepting method B, shall extend in one continuous section through the wall pass-through system and the chimney wall, to but not past the inner flue liner face.

NOTES:

1. Connectors to a masonry chimney, excepting method B, shall extend in one continuous section through the wall pass-through system and the chimney wall, to but not past the inner flue liner face.
2. A chimney connector shall not pass through an attic or roof space, closet or similar concealed space, or a floor, or ceiling.
3. Where passage through a wall, or partition of combustible construction is desired, the installation shall conform to CAN/CSA-B365.

PRODUCT FEATURES AND CONTROLS

PRIMARY AIR CONTROL

The primary combustion air delivery is controlled by the Primary Air Control Assembly (The control knob is located above the fuel door). The heat output can be controlled by sliding the handle to a higher or lower heat output setting (See Care and Operation Section – *Primary Air Control*, page 13). The fuel, the amount of heat and burn times desired, the type of installation are all variables that will affect the control setting. The same control settings in a variety of installations will produce different results. You will need to try different settings so you can learn how much heat to expect and how long the fire will burn.

Primary Air Control Knob

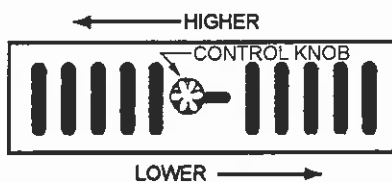

CATALYTIC COMBUSTOR

How it works: From 5 to 30 percent of the chemical energy contained in every log escapes up the chimney when wood is burned in a conventional stove. The catalytic combustor is designed to make use of this energy, converting it into useful heat as it lessens chimney creosote build-up and air pollution. The catalytic combustor consists of a durable temperature resistant ceramic composition, which is extruded into a cellular, or honeycomb, configuration. After extrusion, this ceramic monolith is fired and then covered with a noble-metal catalyst. When wood smoke contacts this catalyst, chemical changes occur that causes the smoke to ignite at temperatures around 600° F. Normally, smoke will ignite and burn only at temperatures around 1000° F.

CATALYTIC BYPASS DAMPER CONTROL

The operating handle of your *Bypass Damper Control* is located on the front of the *Stove Flue Collar*. By moving the *Bypass Damper Control* the operator can route the exhaust either through the *Catalytic Combustor* (pushed in) or directly up the flue (pulled out). When starting a fire or refueling, the *bypass damper control handle* should be pulled out. Once the fire is established it should be pushed in.

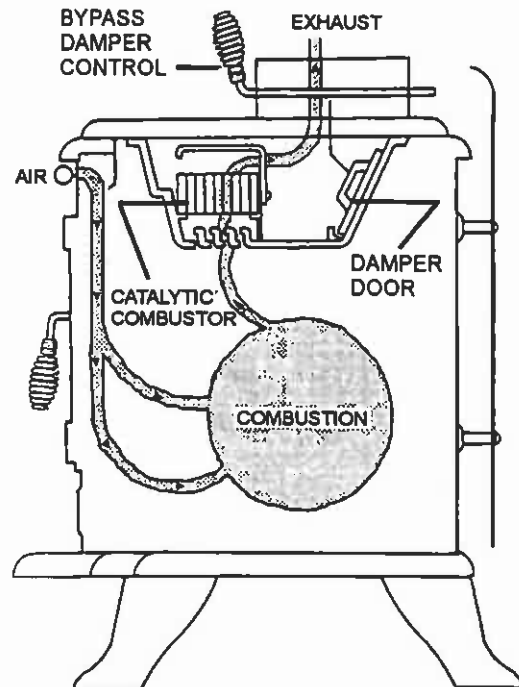

CARE AND OPERATION

FUEL DOOR

CAUTION: WHEN OPENING THE DOOR, DO NOT EXTEND IT BEYOND ITS NORMAL TRAVEL. OVEREXTENDING THE DOOR TO A FURTHER OPEN POSITION CAN PUT EXCESSIVE STRESS ON HINGE AREA OF DOOR AND HINGE PINS AND MAY RESULT IN BREAKAGE.

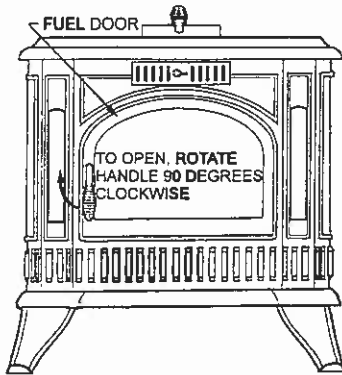

DOOR OPERATION

The door handle assembly opens and securely latches the fuel door closed. To open the door, rotate the coil handle to the 9:00 position until door releases. To close and latch, hold the coil handle in the 9:00 position, close the door, then rotate the handle to the 6:00 position. See illustration above.

GLASS

The Glass is a super heat resistant ceramic that withstands continuous temperatures up to 1390° F. This temperature is well beyond the temperatures in which you operate your stove.

This unit is designed to provide a flow of air over the inside of the glass, where along with high heat helps keep it clean. When operating the stove on low for extended periods of time, the glass may get dirty. A short, hot fire (15 - 20 minutes) will help clean off much of the normal buildup (see *Troubleshooting - Dirty Glass*, page 20). A commercial glass cleaner designed for stoves is recommended for cleaning.

The glass should be cleaned thoroughly with glass cleaner and a soft cloth BEFORE the stove is burned.

PRIMARY AIR CONTROL

This appliance is equipped with a control for the combustion air located above the fuel door. Slide the control to the right for a slower burn rate, to the left for a higher burn rate. It may take a while to get accustomed to the sensitive draft control. Small movements left or right will change the heat output of the stove. To lock the air control in the desired position, turn the knob clockwise. In the open (far-left) position, the fire will kindle more quickly. This should be closed to the medium/low position once the fire is burning well.

You will generally want to set the primary air control on low or medium. The stove is safe burning on any setting as long as combustibles are kept at the specified safe distances.

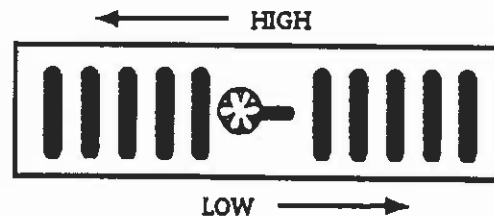

PROVIDE ADEQUATE AIR FOR COMBUSTION

In well insulated and weather tight homes, it may be difficult to establish a good draft up your chimney. The poor draft is caused by a shortage of air in the house. To provide the needed air, crack a window on the windward side of the house.

USE CONTROL SETTINGS THAT WORK FOR YOU

The fuel, the amount of heat you want, the type of installation you have and how long you wish the fire to burn are all variables that will affect the control settings. The same control settings in a variety of installations will produce different results.

Familiarize yourself with your stove by trying different settings so you can learn how much heat to expect and how long the fire will burn. It may take a week or two to learn, but your patience will be rewarded by the warmth and pleasant satisfaction that only a wood fire can provide.

CARE AND OPERATION

BREAK-IN PERIOD

Your stove finish is a high temperature paint that requires time and temperature to completely cure. We recommend that you ventilate the house during the initial burns. The paint emits non-toxic odors during this process.

KEEP YOUR HOUSE WELL VENTILATED DURING THE CURING PROCESS TO PREVENT ACTIVATION OF YOUR HOME SMOKE DETECTOR.

The paint manufacturer recommends three burn cycles to cure the paint. The first two burns should be low heat, approximately 250°F., for 20 minutes each, using paper and light kindling.

After each 20-minute burn, allow the appliance to cool completely. The third burn should be at least medium high or about 450°F. for 45 - 60 minutes. The paint will become soft and emit non-toxic haze during these burns. Keep the area well ventilated.

As the paint cures it will become slightly lighter in color. Eventually the entire surface will become an even color. Once the paint has been softened and cooled two or three times, it will harden. Do not turn on a blower during the curing process. Do not place anything on the stove surface until the paint is completely cured. Do not attempt to repaint the stove until the paint is completely cured. If the surface later becomes stained or marred, it may be lightly sanded and touched up with spray paint from the same paint manufacturer (See *Small Area Paint Touch-Up*, page 17). Paint is available at your local authorized Lennox Hearth Products dealer. Never attempt to paint a hot stove.

CATALYTIC COMBUSTOR

During the start-up of a cold stove, a medium to high firing rate must be maintained for about 20 - 25 minutes. The high firing rate will ensure that the stove, the flue, the catalyst, and the fuel are all stabilized at proper operating temperatures. If the optional temperature probe is used, even though it may reach a temperature of 600° F. within only two or three minutes after the fire is started, do not set the primary air control to the "LOW" position until approximately 20-25 minutes have passed. Setting the primary air control on "LOW" too early could result in either the fire or the catalytic combustor going out.

HOW TO START AND MAINTAIN A FIRE

1. OPEN the bypass damper control by pulling it toward you. In the OPEN position the draft air will bypass the catalytic combustor and make starting the fire easier.
2. Set the primary air control lever on HIGH. The HIGH setting will maximize your primary combustion air.
3. Build a fire directly on the firebrick covering the bottom of the stove.
 - a. Place five or six loosely crumpled sheets of newspaper in the stove.
 - b. Add a small amount of dry kindling randomly on the top of the newspaper.
 - c. Place a few more loosely crumpled newspapers on top of the kindling and light the bottom paper first, then light the top paper.
4. Once the kindling is ignited and burning on its own, close the fuel door. The upper fire should help preheat the chimney and create an effective draft while the lower fire ignites the kindling.
5. When the kindling is burning well, add increasingly larger pieces of wood until the fire is actively burning.
6. When the fire is well established, close the bypass by pushing the control rod in. The optional catalytic temperature probe should read 500-600°F (It takes approximately 20 - 25 minutes to reach this temperature).
7. Set the primary air control to the desired setting. Your stove will now provide efficient and safe heat for your home.

CARE AND OPERATION

Refuelling *

1. Open the damper bypass control by pulling it toward you.
2. Set the primary air control set to high.
3. Open the door approximately 1/2 inch (13 mm), then wait for about thirty seconds. Open the door and add wood, then close the door.
4. If the optional temperature probe is used wait for a reading of approximately 600 degrees, then close the damper bypass control (push it in). If the optional temperature probe is not used, wait approximately 10 minutes, and then close the bypass damper control.
5. Adjust the primary air control to the desired setting.

Notes

- Depending on the type and size of the fuel load as well as the length of time the stove has been burning, your catalytic combustor should operate between 1000 to 1800 degrees.
- (If the optional blower is installed) Ensure blower is turned off during start-up and refueling, as it will affect the accuracy of temperature probe reading.

* If the stove has been burning on a medium to high burn rate for approximately 20 minutes or more, no re-firing is necessary when refueling. Just open the bypass, set the primary air control to high, open the door approximately 1/2 inch (1 cm), and wait for about thirty seconds. Load the fuel, close the door, close the bypass and set the primary air control to normal operation. Temperatures within the firebox should be hot enough to maintain the catalytic operation.

BYPASS DAMPER CONTROL

The operating handle of your bypass damper control is located on the front of the stove flue collar. By moving the bypass damper control, the operator can route the fire either through the catalytic combustor (pushed in) or directly up the flue (pulled out). When starting a fire or refueling, the bypass damper control should be pulled out. Once the fire is established, it should be pushed in.

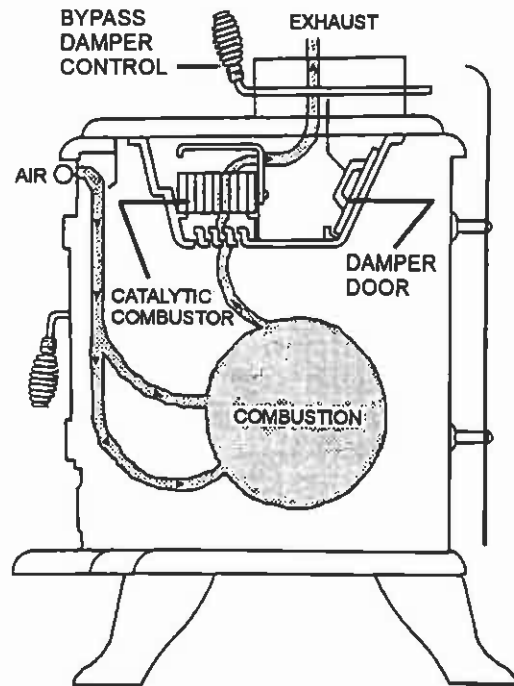

FUEL

BURN RECOMMENDED FUEL

This appliance is approved for use with untreated natural dry wood only (see *Important Warnings*, page 2, #8). Burning materials other than natural wood will shorten the life of the catalytic combustor. Do not burn particleboard or pressed logs using bonding agents as they can produce conditions that will deteriorate metal or damage the catalyst. Green or uncured wood does not work well as fuel, and can cause increased creosote buildups and plugging of the catalytic combustor. The value of green wood as a source of heat is limited. Do not overload or use kindling wood or mill ends for primary fuel as this may cause overfiring. Overfiring is a condition where excessive temperatures are reached, beyond the design capabilities of the stove. The damage that occurs from overfiring is not covered under the stove warranty.

WARNING: BURNING IMPROPER FUEL (I.E. CHARCOAL) CAN RESULT IN CARBON MONOXIDE POISONING WHICH MAY LEAD TO DEATH!

CARBON MONOXIDE POISONING – EARLY SIGNS OF CARBON MONOXIDE POISONING RESEMBLE THE FLU WITH HEADACHES, DIZZINESS, OR NAUSEA. IF YOU HAVE THESE SIGNS, GET FRESH AIR AT ONCE! HAVE THE HEATER INSPECTED BY A QUALIFIED SERVICE TECHNICIAN. SOME PEOPLE ARE MORE AFFECTED BY CARBON MONOXIDE THAN OTHERS. THESE INCLUDE PREGNANT WOMEN, PEOPLE WITH HEART OR LUNG DISEASE OR ANEMIA, THOSE UNDER THE INFLUENCE OF ALCOHOL, AND THOSE AT HIGH ALTITUDES.

WHY SEASONED WOOD?

The key to the success of a good fire that produces heat from a woodstove is the wood. It needs to be well-seasoned natural wood.

What does "Well-Seasoned" mean?

When a tree is cut down, the wood is green, full of sap and moisture. This moisture content can exceed 80%, which must be reduced to less than 20%. Wood properly seasoned is then capable of generating the heat the stove was designed to provide.

Green wood does not burn easily. Attempting to burn green wood often results in a lot of smoke and very little fire. Time is the most important factor in seasoning wood. Ideally the moisture content should be reduced to 11-20%, although very few of us will be able to check that figure. There are several steps that should be taken to ensure that you come close to these figures.

SEASONING GUIDE

Softwoods – 6 months to 18 months

Hardwoods – 12 months to 24 months

Logs that are 5" (127 mm) diameter across or larger should be split in half, three pieces if over 8 inches (203 mm), and four pieces when over a foot (305 mm) across. If the tree fell 2 to 4 years ago, it still needs to be cut, split, and seasoned for 6 to 24 months depending on the wood.

WOOD STORAGE

Wood to be seasoned should be stacked in an area open enough to ensure good air circulation on both sides – leaving adequate space between woodpiles to walk comfortably. Do not stack wood against a wall or building. It helps to elevate the woodpiles off the ground (two 2 x 4's running lengthwise beneath the woodpile works well). This allows air to flow under the bottom logs.

Wood that is kept outdoors, either covered with a tarp, or not covered at all, will not burn well until it has been in an enclosed space for one to two months.

MAINTENANCE

SMALL AREA PAINT TOUCH-UP

The stove body is painted with a quality high-temperature stove paint. Use only model TSPK-B Stove Paint, Catalog # 70K99. Do not touch-up your stove with any other paint.

Using one small piece of 320 grit sand paper and lightly sand the blemish so that the edges are "feathered" or smooth to the touch between the painted and bare surfaces. Do not let the sand paper gum up with paint, as this will cause scratches on the metal surface. If there are any scratches, use 600 grit sandpaper instead. Mask off surfaces you do not want painted. Paint lightly over the bare surface first as this will act as an undercoat. Then paint over a larger area in smooth even strokes to blend.

See *Break-In Period* on page 14 for Information on curing the paint.

ASH REMOVAL AND DISPOSAL

CAUTION: MAKE SURE THAT THE FIRE IS OUT AND THE STOVE IS COLD BEFORE REMOVING ASHES FROM FIREBOX!

Ashes can hold live embers for several days, and must be disposed of with care.

NEVER place ashes in a cardboard box or any other combustible receptacle.

Proper Disposal of Ashes:

Ashes should be placed in a metal container with a tight fitting lid. The closed container of ashes should be placed on a noncombustible floor or on the ground, well away from all combustible materials, pending final disposal. If the ashes are disposed of by burial in soil or other wise locally dispersed, they should be retained in the closed container until all cinders have thoroughly cooled.

DOOR AND GLASS GASKETS

An 1/2" (13 mm) spun fiberglass gasket provides the seal around the fuel door, a 1/8" x 1" (3.2 mm x 25.4 mm) flat woven gasket glass provides the seal around the door glass and the side windows have a 1/8" (3.2 mm) thick lytherm gasket. Should these gaskets become frayed or damaged, they should be replaced with the same size and type as the original gasket. Contact your dealer for ordering. Use high temperature silicone sealer as an adhesive for the fuel door gasket. The (door) glass gasket has a self-adhesive backing. The side window gasket does not require an adhesive (see *Replacement Parts*, pages 23-24).

WARNING: THE GASKETS MUST BE KEPT IN GOOD CONDITION. DO NOT LEAVE THE STOVE BURNING WITH THE DOOR OPEN OR AJAR. THIS WILL CAUSE EXCESSIVE HEAT BUILD UP IN THE UNIT AND COULD IGNITE SURROUNDING COMBUSTIBLES AS WELL AS DAMAGE THE STOVE BY OVERFIRING IT. OVERFIRING IS A CONDITION WHERE EXCESSIVE TEMPERATURES ARE REACHED, BEYOND THE DESIGN CAPABILITIES OF THE STOVE (SUCH DAMAGE IS NOT COVERED BY THE MANUFACTURER'S WARRANTY).

SERVICING GLASS

CAUTION: BE CAREFUL NOT TO ABUSE DOOR ASSEMBLY BY STRIKING OR SLAMMING IT. IF THE DOOR ASSEMBLY OR GLASS IS BROKEN OR DAMAGED, THEY MUST BE REPLACED BEFORE HEATER CAN BE SAFELY OPERATED. USE ONLY COMPONENTS PROVIDED BY THE MANUFACTURER AS REPLACEMENT PARTS.

Cleaning Glass: Ensure stove is cold prior to cleaning glass. A commercial glass cleaner designed for stoves is recommended. Do not use abrasive cleaners.

Replacing Glass:

1. Remove door from stove by lifting door up and off hinge pins: Place the door on a flat protected (towel) clean flat surface with the inside of the door facing up. Remove the glass clips (by removing screws holding clips), then carefully remove broken glass one piece at a time (protective gloves are recommended).
2. Clean the area where the glass with gasket will be installed.
3. Install new glass with gasket (use only factory 5-mm glass with glass channel gasket. Do not substitute). Carefully reinstall glass clips. Be very careful not to overtighten screws.
4. Reinstall door.

MAINTENANCE

CREOSOTE FORMATION AND NEED FOR REMOVAL

What Is Creosote - When wood is burned slowly, it produces tar and other organic vapors, which combine with expelled moisture to form creosote. The creosote vapors condense in the relatively cool chimney flue of a slow-burning fire. As a result, creosote residue accumulates on the flue lining. When ignited this creosote makes an extremely hot fire. Also, creosote deposits tend to form in long runs of venting where gases become too cool prior to exhausting.

To inhibit the build up of creosote, adjust the primary air control to a medium-high or high setting for a 10-minute period each day. Do not attempt to burn out heavy creosote accumulations in this manner. This must be removed from the chimney by scraping or brushing to reduce the risk of a chimney fire.

Burn Approved Fuel Only - This stove is approved for burning dry seasoned natural wood only. Using green or inadequately seasoned wood may increase creosote buildup.

Inspection Frequency - The chimney connector and chimney should be inspected at least twice monthly during the heating season to determine if a creosote buildup has occurred. If creosote has accumulated it should be removed to reduce the risk of a chimney fire.

Cleaning - Remove the catalytic combustor and open the bypass damper prior to having your chimney cleaned (should be done by a qualified chimney sweep). See Maintenance Section, *Catalytic Combustor*, page 19 for instructions on removing catalytic combustor.

IMPORTANT: Make sure the bypass damper is in the open position prior to chimney cleaning.

In the event of a chimney fire - Make sure the fuel door is securely closed. Adjust the primary air control to the lowest (most closed) setting. Call the fire department immediately. After a chimney fire, the complete chimney system should be checked by a qualified technician before further use.

Consult your dealer for suggestions on proper chimney care. Contact your local municipal or provincial fire authority for information on how to handle a chimney fire. Have a clearly understood plan for handling a chimney fire.

CATALYST REPLACEMENT

The normal expected life of a catalyst (catalytic combustor) is 10,000 to 12,000 hours if the appliance is operated correctly and proper fuels are used. If the catalyst has been deactivated, it should be replaced. Symptoms of deactivation include – noticeably darker smoke exiting chimney and less heat output. If these symptoms remain after normal maintenance or a major cleaning (soak in heated vinegar/water solution, see page 19), the catalyst, p/n 14000 will require replacement (also, if the catalyst is broken and / or missing large pieces, it should be replaced). Note: The catalyst does not need to be glowing to be working. It will glow at times, but it can work very effectively at temperatures well below the 1000° F level (at which it will begin to glow).

Stove Operation If Catalyst Is Deactivated – It is safe to operate the appliance temporarily with a deactivated catalyst (although it will be out of compliance with EPA certification requirements). To operate, follow normal lighting and refueling procedures as outlined in this manual with one the following exceptions.

- During start-up, disregard catalytic temperature probe reading to determine when to close bypass damper control. Instead allow 20-25 minutes, then close the bypass damper control.
- During refueling, disregard catalytic temperature probe reading to determine when to close bypass damper control. Instead allow 3-5 minutes after refueling, then close the bypass damper control.

CLEANING BLOWER INTAKE

If an optional blower kit (catalog #14M36) is installed, the blower air intake requires cleaning at least once a year to remove lint, dust, etc. If there are pets in the dwelling, the intake should be cleaned at least twice a year.

STOVE SEAMS

The stove body seams should be inspected at least once a year. If any seams are found to be loose or damaged, the seam should be cleaned with a wire brush then resealed with furnace cement.

FIREBRICK

The firebrick should be inspected periodically and replaced if damaged (crumbling or excessively cracked).

MAINTENANCE

CATALYTIC COMBUSTOR

Your stove has been designed with a catalytic combustor, which will improve the overall efficiency of your stove. Removing the combustors for cleaning, inspection and reinstallation should be done at least once a year. Cleaning the combustors helps reduce buildup of ash and retarding chemicals. To clean the combustors, a soft brush, vacuum cleaner, or pipe cleaner may be used. Another effective cleaning method is to soak the combustors in a hot cleaning solution of a 50/50 mixture of white vinegar and distilled water for 30 minutes. Then rinse by soaking in hot distilled water. After 15 minutes, remove the combustors from the rinse water and gently shake out excess water. It is unlikely that you will notice a visible difference in the combustors after this cleaning procedure. The combustor units are fragile in comparison to the rest of the stove - so handle with care. Cleaning the combustors once a year, preferably when your flue system is serviced, is sufficient for most users. Reinstall the combustor set according to the following instructions.

1. Disconnect pipe from stove flue outlet.
2. Looking down into stove flue, remove the bypass-operating rod and control arm set screws using an Allen wrench.
3. Remove the 2 bolts that hold the top in place (located on the underside center left and right side of the top). Lift off the stovetop.
4. Remove the catalytic housing by removing the 4 bolts on the underside of the top.
5. The catalytic combustor is now visible under the stainless steel shield. Although it may be covered with a light ash, it should be relatively free of obstructions in the honeycomb cells.

6. Care should be taken to leave the gasketing in position when removing catalyst. This gasketing seals the catalyst.
7. To reinstall, first remove the old stove cement from the stovetop and top edges (use a wire brush). Re-seal all gaps, including sides and base with a high temperature cement or silicone gasket available from your dealer.

Reinstall the catalyst housing and top. When tightening down bolts on top, turn only a 1/4 turn and go to the next bolt being careful not to overtighten as this will strip the threads.

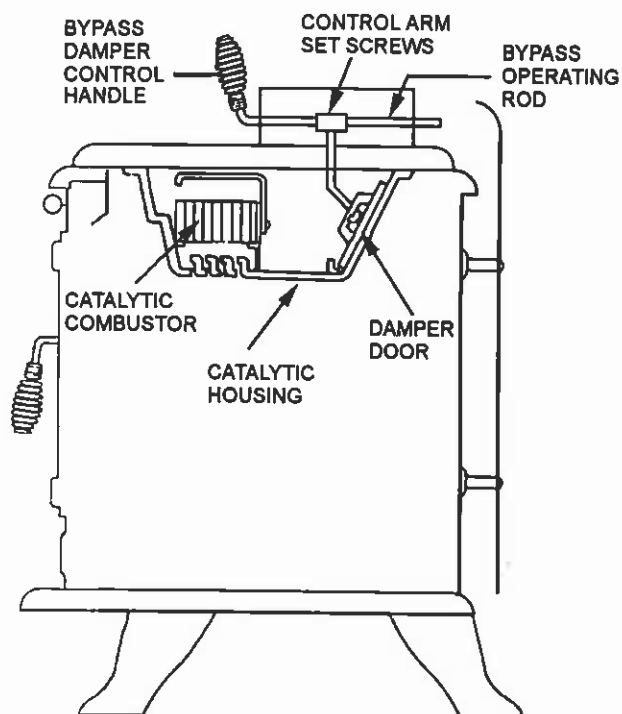

TROUBLESHOOTING

SMOKES OUT FUEL DOOR WHEN OPEN (see *)

1. The primary air control is closed.
2. The chimney is too cool. Set the primary air control on "HIGH" with the bypass damper control "OPEN" for a few minutes before opening the fuel door.
3. Excess creosote will not only restrict your draft but it will create a risk of a creosote fire. Strictly adhere to maintenance requirements as outlined in this manual. If excess creosote has built up on the inside of the firebox sides and door, burn a small hot fire at intervals that are more frequent with air control on HIGH for a few minutes.
4. Deposits may have built up in the chimney and are restricting the draft, or the spark arrester on top of the chimney may be plugged.
5. Chimney diameter too large or too small to provide adequate draft.
6. The house is too airtight (usually takes 20 to 30 minutes for problem to appear as stove lowers air pressure in house). Crack a window open or provide an outside source of air near stove.
7. Insufficient vertical height to chimney to achieve adequate draft.
8. The combustor is plugged from engaging too soon (remove combustor and clean, see *Maintenance* section, pages 17-19).

DOES NOT PRODUCE ENOUGH HEAT (*)

1. Using green or insufficiently cured wood.
2. Excessive draft.
3. High ceilings (heat rises quickly, but can be recirculated by a well-placed ceiling fan with a winter/summer switch).
4. The area to heat, is too large (square foot (305 square mm) heating estimates are based on "average" climates and home design).
5. There is an obstruction in the chimney.
6. The chimney or chimney cap is restricted by creosote preventing enough draw to sustain a "HIGH" heat rate.
7. Combustor light off has not occurred.

DOES NOT MAINTAIN A FIRE (*)

Soft wood does not burn as long or as well as seasoned hardwood resulting in a short burn time.

1. Wood size too small. Burns at too rapid a rate.
2. The gasket seal on the fuel door, or glass is leaking air. Repair or replace it if necessary.
3. There is an obstruction in the chimney
4. The stove was not up to normal operating temperature before the bypass damper control was pushed closed.
5. Excessive draft.

BACKPUFFING (*)

1. Downdraft in the chimney (may need a special wind cap).
2. The catalytic combustor is too hot (avoid burning soft, pitchy woods, or large amounts of small-diameter wood).
3. The house is too air tight (ventilation is needed).
4. Insufficient vertical height to chimney to achieve adequate draft.

ODORS

1. Creosote accumulation in firebox (brush out on next cleaning).
2. Chimney downdraft when stove is not operating (close primary air control).
3. Catalytic combustor not functioning.
4. Paint curing on first several burns.

DIRTY GLASS (*)

1. Poor draft conditions.
2. Long burn periods at low draft settings.
3. Burning wet, pitchy or spongy wood.
4. Poorly arranged logs (too close to glass).

CATALYST PLUGGING

1. Burning materials that produce a lot of char and fly ash. Do not burn materials such as garbage, gift wrap, cardboard, etc.
2. Burning wet pitchy woods or burning large loads of small diameter wood with the combustor in the operation position (without light-off taking place). Burn proper fuel only. Do not close bypass until temperatures are high enough to initiate light off.

CATALYST DEACTIVATION

1. Burning large quantities of trash, pressure-treated lumber or painted woods, etc. will deactivate the catalyst. Burn proper fuels only. See *Catalyst Replacement*, page 18.

(*) **Draft problems; If installing into a larger flue, it may be necessary to use a full length liner to achieve adequate draft for the appliance. A draft gauge should read a minimum of .05" w.c. (Inches water column) not to exceed .07" w.c. for optimum performance (see *Draft Requirements*, page 9).**

TROUBLESHOOTING

CATALYST SUBSTRATE CRACKING

1. Normal operation, as long as combustor remains intact. If cracking causes large pieces to fall out, replace combustor.
2. Mishandling or abuse. Handle with care.
3. Warped housing (see *Overfiring Damage* on this page).

CATALYST SUBSTRATE

1. Extreme thermal shock. Combustor is being worked too hard.
2. Excessive draft. Correct installation (see *Draft Requirements*, page 9).

CATALYST PEELING

Extreme Temperatures (over-firing) at combustor surface can cause the catalyst to peel. Some minor peeling does not affect function. Severe peeling would close cell openings and cause a plugging problem. If peeling is severe, replace combustor. Do not overfire appliance. See *Overfiring Damage* on this page.

TAR AND LIQUID CREOSOTE LEAKING FROM METAL FLUE JOINTS

1. No chimney cap on chimney. Install cap.
2. Metal flue assembled improperly. Top flue sections should be inserted into lower flue sections.

DENSE SMOKE LEAVING CHIMNEY

1. Water vapor (on cold still days water vapor may be mistaken for smoke). Water vapor is normal and should be of little concern.
2. Wet, pitchy woods being burned. Burn dry seasoned wood only.
3. Bypass in open position. Close bypass.
4. Combustor not functioning. See *Catalyst Replacement*, page 18.

OVERFIRING DAMAGE

If the heater or chimney connector glows, the appliance is overfiring. Other symptoms may include: Cracking, warping or burning out of components, catalytic combustor may deteriorate, stove glass may develop a haze which will not come off with cleaning, catalytic combustor housing grate may crumble, etc. Overfiring of a stove is a condition where excessive temperatures are reached, beyond the design capabilities of the appliance. The damage that occurs from overfiring is not covered under the manufacturer's limited warranty. The following are a few conditions that should be evaluated and (corrected if necessary) if an overfiring condition is suspected:

Overfiring Caused From Improper Installation

The venting system must satisfy the draft Requirements of the appliance. The appliance is merely one component of a larger system. The other equally important component is the venting system, which is necessary for achieving the required flow of combustion air to the fire chamber and for safely removing unwanted combustion byproducts from the appliance. If the venting system's design does not promote these ends, the system may not function properly, which may create performance problems as well as may be a safety hazard. To ensure that all installation requirements have been met as outlined in the installation manual. The chimney should be clean and in good repair. A draft test should be performed to determine if the draft requirements of the appliance are being met. A draft gauge should read between .05 and .07 inches water column (W.C.I.). Excessive draft (above .07 W.C.I.) will allow too much combustion air to be pulled into the firebox, which results in hotter burns. Too little draft (below .05 W.C.I.) will not allow enough combustion air delivery to maintain a fire well or cause performance problems such as smoking (this may result in improper operation of appliance, i.e. will not maintain fire well unless catalytic bypass is left open, or with fuel door left open (see following - *Overfiring Caused From Improper Operation*).

Overfiring Caused From Improper Operation

Operate this stove only as outlined in this manual. Never burn the stove with the fuel door open or ajar. Do not operate this stove with the air intake control in the "open" position for extended periods (this wastes fuel and can cause dangerous overfiring conditions). NEVER leave the stove unattended on high settings.

Overfiring Caused From Improper Maintenance

Strictly adhere to all maintenance requirements at frequent intervals as prescribed in this manual including cleaning of flue and stove. Should the fuel door or glass gaskets become frayed, worn or damaged, they should be replaced with same size and type as original.

Overfiring Caused From Improper Fuel

This appliance is approved for use with natural dry well seasoned wood only (consult your dealer for approved fuels in your area). Do not burn garbage, particleboard scraps, or pressed logs using bonding agents because they can produce conditions that will deteriorate metal. Do not overload or use kindling wood or mill ends as primary fuel as this may cause overfiring. If any of the stove body seams are found loose or damaged, the seams should be cleaned with a wire brush then resealed with furnace cement (this needs to be done annually, see *Stove Seams*, page 18).

SPECIFICATIONS: Model T150C

Approximate Heat Capacity	Up to ~1800 sq. ft. Up to ~550 sq. M
Maximum Burn Rate	49,027 BTU
EPA BTU Range	6500 / 35,300 BTU
Emissions Rate (grams/hr.)	4.1
Efficiency Rating	72%
Outside Air Provision	No
Maximum Log Length	22" (559 mm)
Firebox Size (cubic feet)	2.5 c.f. (762 cu. mm)
Stove Back to Flue Center	8" (203 mm)
Flue Position	Top
Flue Collar Size	6" (152 mm)
Approx Burn Time	8 - 12 hours
Fuel Capacity	55 lbs. (25 kg)
Loading	Front
Catalyst	Standard
Width	27" (686 mm)
Depth	22.5" (572 mm)
Height (to flue)	29" (737 mm)
Height	26.5" (673 mm)
Approx Weight With Brick	365 lbs. (166 kg)
Blower (Optional) W/ speed control	160 CFM Rheostat (75v - 110v)

Dimensions shown are approximations only (+/- 1/4" [6.4 mm])

- Square feet heating capacity and burn time are approximations only. They will vary depending upon the level of insulation, climate, house design, ceiling height, ambient outside temperatures and how the stove is operated.

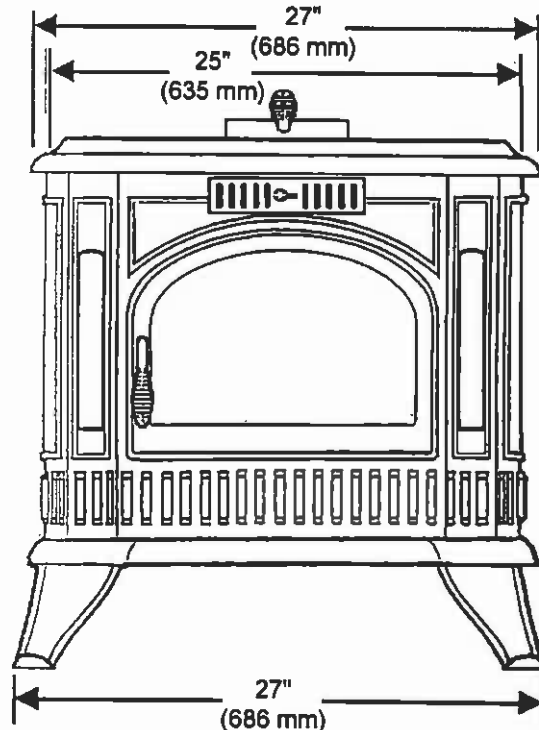
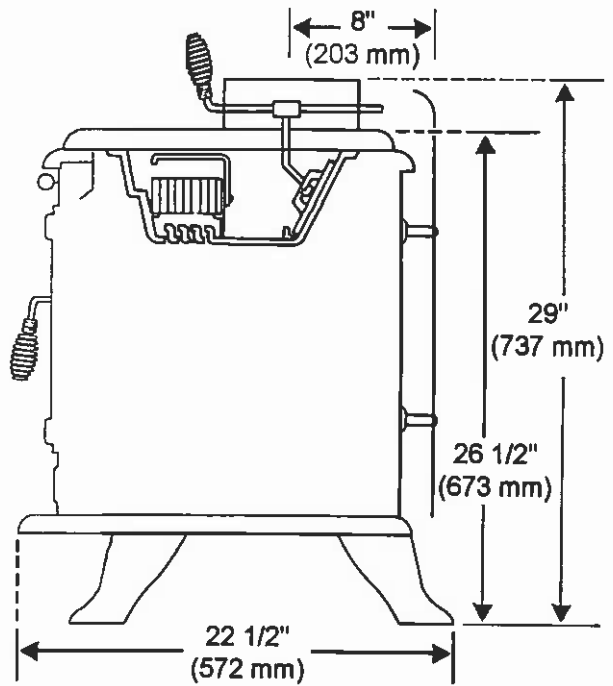

REPLACEMENT PARTS FOR MODEL: T150C

Part No.	Model	Description
		Door Parts
C15220		Door Assembly, Cast (Handle Included)
27M83		Gasket Kit, 1/2" Medium Rope
26M23		Gasket Kit, Side Window 1/8" Lytherm ⊗
27M81		Gasket Kit, Door Glass Channel
18280		Glass, Door 9 5/8 X 14 1/4" (Glass gasket not included)
18281		Glass, Side 3 X 9 5/8" (Glass gasket not included)
T10263		Clip, Glass (door-order 10, side windows 2 each)
26M80		Handle Assembly
T153		Hinge Pin, Threaded 5/16"-18
10362		Torque Plate (Latch)
		Module Assembly Parts
26M67		Module, Draft Control
		Component Parts
28M09		Gasket, 1/2" Medium Density Rope
26M25		Leg Set (4)
T100-11		Stack Assembly, 6" (Also requires 28M09 Gasket Kit)
26M78		Top, Cast Stove
		Heat Shield Parts
29108		Shield, Bottom Heat
29110		Shield, Rear Heat
		Firebox Parts (See Brick Diagram For Brick Part Number)
Z-SC-103		Combustor, 5 X 3 1/2" (Set Of 2) Includes Gasket
26M79		Housing, Combustor (Also requires 28M09 Gasket)
26M24		Damper Kit, Bypass (includes damper, linkage and rod)
14155		Gasket, Interam 1/8" For Combustor - Requires 2
8076		Handle Bypass, Spring Coil
		Miscellaneous Parts
18201		Cerawool Pad, For Marble - Requires 1
1051		Cerawool Strip, For Marble - Requires 4
775008M		Installation / Operation Manual
		Fan System (Optional Kit)
26M22		Power Cord Kit
14440		Dial -A- Temp (Rheostat)

For the location of the nearest Lennox Hearth Products Dealer for replacement parts, contact:

Lennox Hearth Products
 1110 West Taft Avenue
 Orange, CA 92865

COMPONENT DIAGRAMS: T150C

FIREBRICK (1 1/4" thick)

Part	Qty	Dimensions
FB-1	9	9 x 4 1/4" Regular

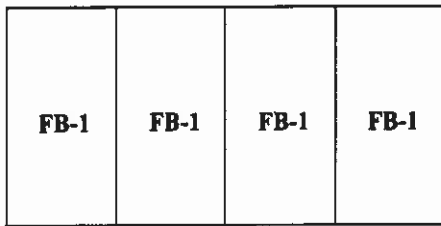

BACK

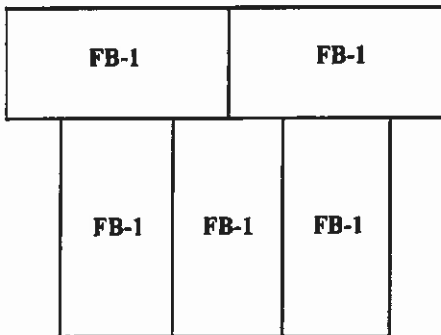

BOTTOM

Top View Showing Brick Installed

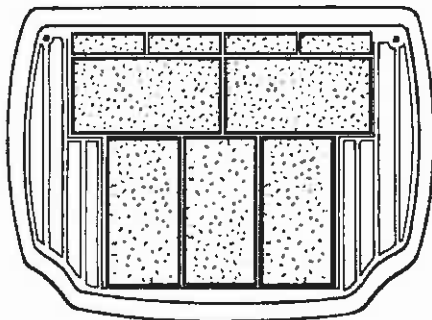

CATALYTIC COMBUSTOR System Components

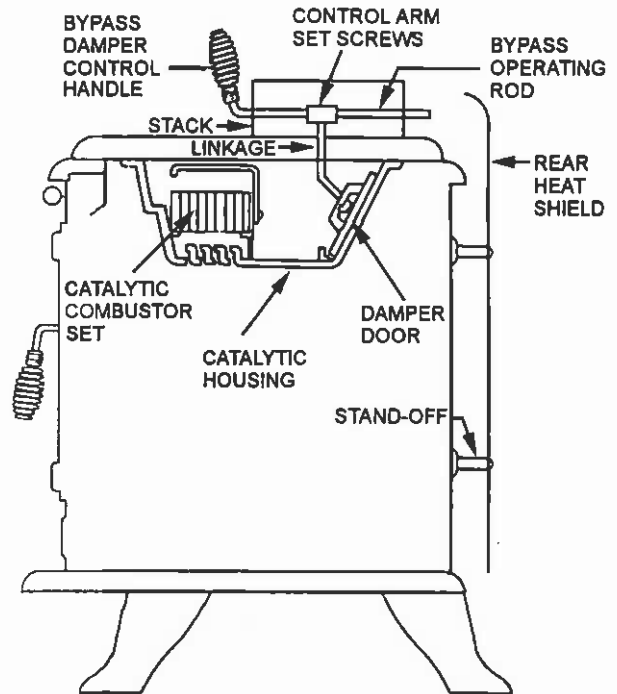

OPTIONAL ACCESSORIES: T150C

Note: Install and use accessories per Instructions provided with the accessory kit.

Catalog #	Model	Description	Notes
14M36	BK-T15	Blower Kit	Includes Dial-A-Temp for Variable Speed Control
14M21	SSK	Stove Stat Kit	Thermally Controls Blower
14M34	MKT15-GRY	Marble Set-Gray	Accent for stove top and ash lip
14M35	MKT15-GRN	Marble Set-Green	Accent for stove top and ash lip
H0310	TP-FS	Probe, Catalytic Temperature	
70K99	TSPK-B	Touch-up Spray Paint Kit, Black	12 oz Spray Can

Blower Kit (BK-T15)

A Blower Kit (includes rheostat for variable speed control) is available for increased heat circulation.

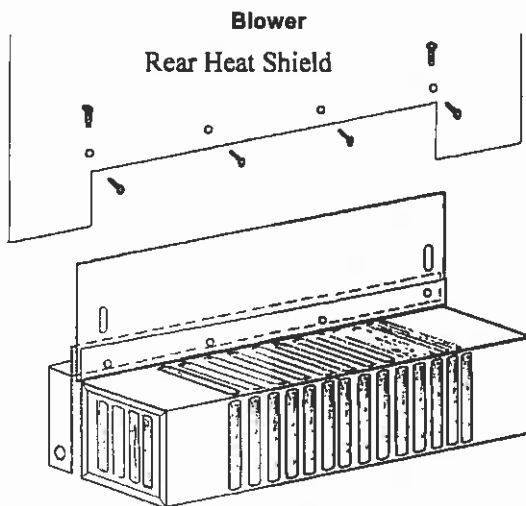

Variable Speed Control, Dial-A-Temp

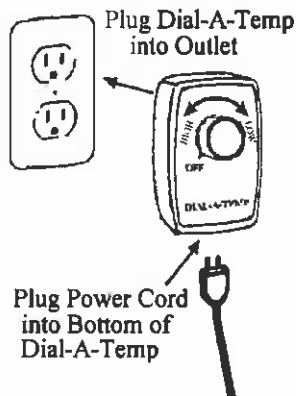

Stove-Stat Kit (SSK)

To automate the blower system an additional Stove-Stat kit can be purchased. The Stove-Stat is a heat sensor switch that will automatically turn on the blower when the stove is hot and automatically turn it off when the stove is cool.

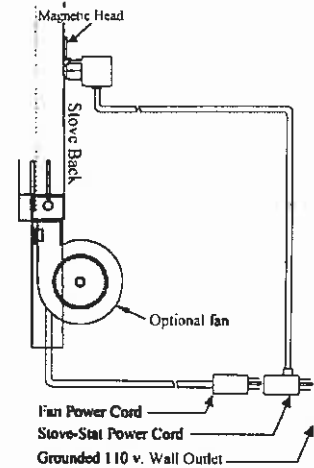

Marble Set

Available in Green (MKT15-GRN), or Gray (MKT15-GRY).

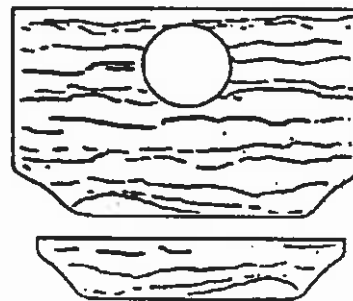

TEMPERATURE PROBE (TP-FS)

Optional marble cannot be used when temperature probe is used.

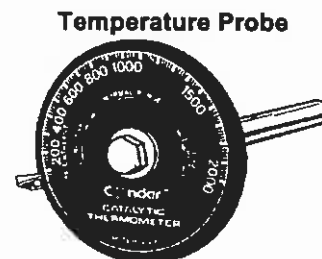

SAFETY/LISTING LABEL

CONTACT YOUR LOCAL BUILDING OR FIRE OFFICIALS ABOUT RESTRICTIONS AND INSTALLATION INSPECTION IN YOUR AREA
CONTACTEZ LE BUREAU DE LA CONSTRUCTION OU LE BUREAU DES INCENDIES AU SUJET DES RESTRICTIONS ET DES INSPECTIONS D'INSTALLATION DANS VOTRE VOISINAGE

Listed Room Heaters, Solid Fuel Type / Appareils de Chauffage de Pièce, de Combustibles Solides
FOR USE WITH SOLID WOOD FUEL ONLY / POUR USAGE AVEC LE BOIS SEULEMENT



Model / Modèle: T150C
Serial No. / Numéro de Série

Empty box for serial number entry

Manufactured by / Manufacturé par:
LENNOX HEARTH PRODUCTS
1110 West Taft Ave.
Orange, CA 92665



PREVENT HOUSE FIRES

Install and use only in accordance with manufacturer's installation instructions and your local building codes.
CAUTION: Special methods are required when passing chimney through a wall or ceiling, refer to local building codes.
DO NOT pass chimney connector through a combustible surface.
DO NOT connect this unit to a chimney flue serving another appliance.
NOTE: Replace glass only with 5mm ceramic. Rear and bottom heat shields required for residential installation.
Tested To: UL 1482, ULC S-627
Type Of Fuel: Solid Wood Only
Electrical Rating: 115 VAC, 0.9 Amp, 60 Hz.
Optional Fan Kit: #14M36

DANGER: Risk of electrical shock. Disconnect power before servicing unit. Do not route power cord under or in front of appliance.
CATALYTIC COMBUSTOR: Applied Ceramics (Part No. 14000). Burning of metal foils, coal, plastic, garbage, diesel oil and sulphur will make the catalyst in the converter inactive. The combustor is fragile; handle carefully. Do not operate without catalyst. The performance of the catalytic device or its durability has not been evaluated as part of the certification.

PREVENTION DES FEUX DE MAISON

Installez et utilisez en accord avec les instructions d'installation du fabricant et des codes locaux.
AVIS: Prenez des précautions spéciales lorsque vous faites passer une cheminée à travers un mur ou un plafond, référez-vous aux codes locaux de la construction.
Ne pas faire passer le tuyau de cheminée à travers une surface combustible.
Ne pas connecter cet appareil à un tuyau de cheminée servant un autre appareil.
NOTE: Remplacez la vitre avec une céramique de 5 mm seulement. Les protecteurs de chaleur de l'arrière et du bas sont exigés pour les installations résidentielles.
Testé à: UL 1482, ULC S-627
Type de Combustible: Bois Solide Seulement
Puissance Électrique: 115 VAC, 0.9 Amp, 60 Hz
Ventilateur Optionnel: #14M36
DANGER: Il y a risque de décharge électrique. Déconnectez le fil électrique de la prise de contact avant le service. Ne pas laisser passer le fil électrique sous ou en avant de l'appareil.
COMBUSTEUR CATALYTIQUE: Applied Ceramics (pièces nu.: 14000). Brûler des feuilles de métal, du charbon, du plastique, des vidanges, de l'huile diesel et du soufre rendra le catalytique inactif. Le combusteur est fragile; en prendre bon soin. Ne pas opérer sans le catalytique. La performance du mécanisme catalytique ou sa durabilité n'ont pas encore été évaluées comme faisant partie de la certification.

STOVE INSTALLATION: In a parallel installation, minimum clearance of the stove to combustible sidewall is 30", backwall is 11", the connector to combustible sidewall is 40", the backwall is 16".
INSTALLATION DU POÊLE: Dans une installation parallèle, l'espace libre minimum du poêle au mur de côté combustible est de 30", de 11" du mur arrière, de 40" du connecteur au mur de côté combustible, de 16" au mur arrière. Dans une installation du coin, l'espace libre minimum du connecteur au mur combustible est de 30".



Floor protector must be non-combustible material, extending beneath heater and to the front/sides/rear as indicated.
Le protecteur de plancher doit être de matériel incombustible, s'étendant en dessous de l'appareil de chauffage et de l'avant/des côtés/et de l'arrière comme indiqué.
*In Canada, required floor protection must be 18" (450mm) in front and 8" (200mm) on all other sides of the appliance.
*Au Canada, la protection du plancher doit s'étendre de 18" (450mm) en avant et de 8" (200mm) sur tous les autres côtés de l'appareil.

CONNECTOR PIPE & CHIMNEY: 6 inch diameter, single wall, minimum 24 MSG black or 25 MSG blue steel connector pipe with listed factory-built UL 103 HT chimney suitable for use with solid fuels or masonry chimney. Horizontal connector permitted in accordance with NFPA 211 requirements.

TUYAU CONNECTEUR ET CHEMINÉE: Le tuyau connecteur en acier noir de minimum 24 MSG ou en acier bleu de 25 MSG, de 6" de diamètre, pour mur simple, avec cheminée faite en usine, enregistrée sous UL-103HT pour usage avec les combustibles solides ou une cheminée de briques. Le connecteur horizontal est permis en accord avec les règlements NFPA 211.

CAUTION: HOT WHILE IN OPERATION. DO NOT TOUCH. CONTACT MAY CAUSE SKIN BURNS. KEEP CHILDREN, CLOTHING, FURNISHINGS AND COMBUSTIBLE MATERIAL A CONSIDERABLE DISTANCE AWAY. SEE NAMEPLATE AND INSTRUCTIONS. DO NOT OVERFIRE. IF HEATER OR CHIMNEY CONNECTOR GLOWS, YOU ARE OVERFIRING. INSPECT AND CLEAN CHIMNEY AND CONNECTOR FREQUENTLY. UNDER CERTAIN CONDITIONS OF USE, CREOSOTE BUILDUP MAY OCCUR RAPIDLY. DO NOT USE GRATE OR ELEVATE FIRE - BUILD WOOD FIRE DIRECTLY ON HEARTH. DO NOT BURN WITH FEED DOOR OR FLUE BYPASS OPEN. FEED DOOR MUST BE CLOSED DURING FIRING EXCEPT WHEN ADDING FUEL. OPEN FLUE DRAFT BEFORE OPENING FEED DOOR.



ATTENTION: CHAUD LORS DE L'OPÉRATION. NE PAS TOUCHER. LE CONTACT PEUT CAUSER DES BRÛLURES À LA PEAU. GARDEZ LES ENFANTS, LES VÊTEMENTS, LES MEUBLES ET LES MATÉRIEAUX COMBUSTIBLES LOIN DE L'ESPACE DÉSIGNÉ DE L'APPAREIL. VOIR L'ÉTIQUETTE ET LES INSTRUCTIONS. NE PAS SURCHAUFFER. SI L'APPAREIL DE CHAUFFAGE OU LE TUYAU DE CHEMINÉE ROUGISSENT, VOUS SURCHAUFFEZ. INSPECTEZ ET NETTOYEZ LA CHEMINÉE FREQUENNEMENT. SOUS CERTAINES CONDITIONS, IL SE PEUT QUE LA CREOSOTE S'ACCUMULE RAPIDEMENT. N'ÉLEVEZ PAS LE FEU. BÂTISSEZ LE FEU DE BOIS DIRECTEMENT SUR L'ÂTRE. NE PAS BRÛLER LORSQUE LA PORTE D'OUVERTURE OU LA PORTE BY-PASS SONT OUVERTES. LA PORTE D'OUVERTURE DOIT ÊTRE FERMÉE PENDANT L'USAGE EXCEPTÉ PENDANT QUE VOUS AJOUTEZ DU FEU. OUVREZ LE TUYAU D'AIR ET LA PORTE BY-PASS AVANT D'OUVRIR LA PORTE D'OUVERTURE.

U.S. ENVIRONMENTAL PROTECTION AGENCY
Certified to comply with July 1990 particulate emission standards.
This wood heater contains a catalytic combustor, which needs periodic inspection and replacement for proper operation. Consult owner's manual for further information. It is against the law to operate this wood heater in a manner inconsistent with operating instructions in the owner's manual, or if the catalytic element is deactivated or removed.

Date of Manufacture / Date de Fabrication
2002 2003 2004 Jan. Feb. Mar. Apr. May June July Aug. Sept. Oct. Nov. Dec.
DO NOT REMOVE THIS LABEL / NE PAS ENLEVER OU RECOUVRIR CETTE ÉTIQUETTE
Made in U.S.A. / Fait aux États-Unis
P/N 11605 Rev. C

EPA LABEL

Manufactured by: Lennox Hearth Products Model: T1006C / T160C

US ENVIRONMENTAL PROTECTION AGENCY

CATALYST EQUIPPED

MEETS EPA PARTICULATE MATTER (SMOKE) CONTROL REQUIREMENTS FOR CATALYTIC WOOD HEATERS BUILT ON OR AFTER JULY 1, 1990. SEE CATALYST WARRANTY. ILLEGAL TO OPERATE WHEN CATALYST IS NOT WORKING. SEE OWNER'S MANUAL FOR OPERATION AND MAINTENANCE.

SMOKE

THIS MODEL

0 (Grams Per Hour) 5.5

EFFICIENCY *

50% 60% 70% 80% 90% 100%

Wood heaters with higher efficiencies cost less to operate.
*(NOT TESTED FOR EFFICIENCY. THE VALUE INDICATED IS FOR SIMILAR CATALYST-EQUIPPED WOOD HEATERS.)

HEAT OUTPUT
6,500 to 35,300 Btu/Hr

Use this to choose the right size appliance for your needs.
ASK DEALER FOR HELP

This wood heater will achieve low smoke output and high efficiency only if properly operated and maintained. See owner's manual.

OWNERSHIP RECORDS

Dealer's Name:

Dealer's Address:

City:	State:	Zip Code:
-------	--------	-----------

Serial Number:	Date of Purchase:	Date Installed:
----------------	-------------------	-----------------

Notes:

--

--

--

SERVICE AND MAINTENANCE LOG

Service Date	Service Technician	Service Description
--------------	--------------------	---------------------

--	--	--

--	--	--

--	--	--

--	--	--

--	--	--

--	--	--

--	--	--

--	--	--

--	--	--

--	--	--

--	--	--

--	--	--

--	--	--

--	--	--

--	--	--

--	--	--

--	--	--

--	--	--

--	--	--

LENNOX[®]

HEARTH PRODUCTS
1110 West Taft Avenue
Orange, CA 92865

