



BAJA II

36" Wood Burning Fireplace
 Models: 36WL Circulating (Louvered)
 36WIL Circulating (Louvered) Fully Insulated
 36WS Non-Circulating (Smooth Face)
 36WIS Non-Circulating (Smooth Face) Fully Insulated

INSTALLATION INSTRUCTIONS

SAVE THIS BOOK

This book is valuable. In addition to instructing you on how to install and maintain your appliance, it also contains information that will enable you to obtain replacement parts or accessory items when needed. Keep it with your other important papers.

This fireplace is approved for use as a wood burning fireplace or for use with a vented gas log approved to ANS Z21.60, Z21.84 or RGA 2-72 standards or for use with a vent-free gas log heater approved to ANS Z21.11.2 standard. A DESA hood must be installed when using a vent-free gas log heater (see Accessories, p. 10).

WARNING: ALWAYS LEAVE GLASS DOORS FULLY OPENED OR FULLY CLOSED WHEN OPERATING THIS FIREPLACE.

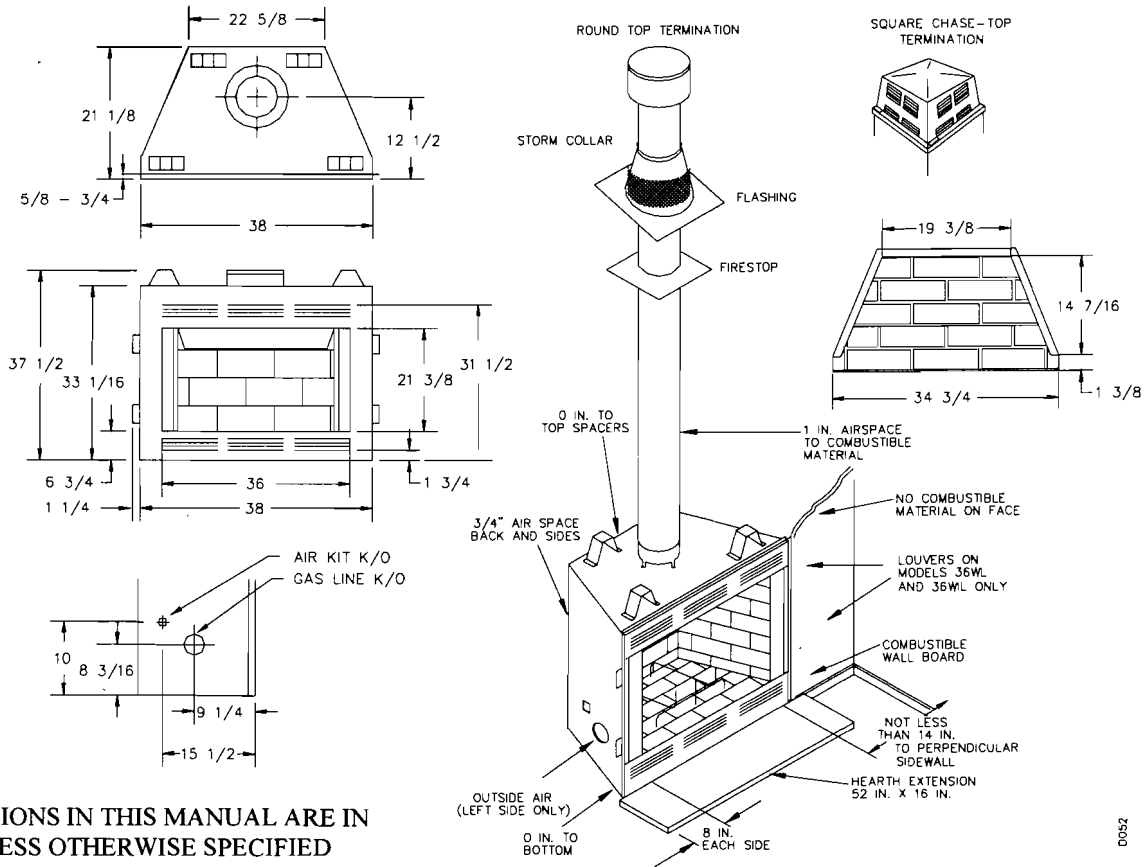

ALL DIMENSIONS IN THIS MANUAL ARE IN INCHES UNLESS OTHERWISE SPECIFIED

DESA INTERNATIONAL
 2701 INDUSTRIAL DRIVE
 P.O. BOX 90024
 BOWLING GREEN, KY 42102-9004
 www.desatech.com



P/N 107180-01
 REV B
 2/01

CONTENTS

1. INTRODUCTION	-----	PG. 2
2. SELECTING LOCATION	-----	PG. 2
3. MINIMUM CLEARANCES	-----	PG. 2
4. FRAMING AND INSTALLING	-----	PG. 3
5. HEARTH EXTENSION	-----	PG. 3
6. OUTSIDE AIR KIT INSTALLATION	-----	PG. 4
7. FAN KIT ASSEMBLY	-----	PG. 4
8. CHIMNEY PIPE INSTALLATION	-----	PG. 4,5,6
9. TERMINATIONS	-----	PG. 6
10. FINISHING YOUR FIREPLACE	-----	PG. 7
11. MANTELS	-----	PG. 7
12. GLASS DOORS	-----	PG. 7
13. GAS LINE INSTALLATIONS	-----	PG. 8
14. CHIMNEY OFFSET	-----	PG. 9
15. DAMPER OPERATION	-----	PG. 10
16. TECHNICAL SERVICE	-----	PG. 10
17. REPLACEMENT PARTS AND ACCESORIES	-----	PG. 11

FOR YOUR SAFETY

- Do not store or use gasoline or any other flammable vapors or liquids in the vicinity of this or any other appliance.
- Due to high temperatures, the appliance should be located out of traffic and away from furniture and draperies.
- Do not place clothing or other flammable materials on or near the appliance.
- NEVER leave children unattended when a fire is burning in the fireplace.

WARNING: IMPROPER INSTALLATION, ADJUSTMENT, ALTERATION, SERVICE OR MAINTENANCE CAN CAUSE INJURY, PROPERTY DAMAGE, OR LOSS OF LIFE. REFER TO THIS MANUAL FOR ASSISTANCE OR ADDITIONAL INFORMATION. CONSULT A QUALIFIED INSTALLER OR LOCAL DISTRIBUTOR.

CHECK LOCAL CODES BEFORE INSTALLING THIS FIREPLACE.

INTRODUCTION

BEFORE YOU BEGIN

- ◆ Before beginning the installation of the fireplace, read these instructions through, completely.
- ◆ These DESA components and fireplace are safe when installed according to this Installation Manual. Unless you use DESA components, which has been designed and tested for the fireplace system, you may cause a fire hazard.
- ◆ The DESA warranty will be voided by and DESA disclaims any responsibility for the following actions:
 - a) Modification of the fireplace, components, doors, blower, fans, air inlet system and damper control.
 - b) Use of any component part not manufactured or approved by DESA in combination with a DESA fireplace system.

PROPER INSTALLATION is the most important step in ensuring safe and continuous operation of the fireplace. Consult the local building codes as to the particular requirements concerned with the installation of all factory built fireplaces. Although grounding may not be required by code the manufacturer recommends it.

WARNING: DO NOT INSTALL A FIREPLACE INSERT IN THIS BOX UNLESS THE MANUFACTURER'S INSTRUCTIONS WITH THE INSERT SPECIFICALLY STATE THIS FIREPLACE HAS BEEN TESTED FOR USE WITH THE INSERT.

This fireplace is intended to be used as a decorative appliance and is not intended to be used to heat the home.

This wood burning fireplace complies with UL 127 standard as a FACTORY BUILT FIREPLACE.

SELECTING LOCATION

To determine the safest and most efficient location for the fireplace, you must take into consideration the following guidelines:

1. The location must allow for proper clearances (see figures 1 & 2).
2. Consider a location where the fireplace would not be affected by drafts, air conditioning ducts, windows or doors.
3. A location that avoids the cutting of joists or roof rafters will make installation easier.
4. An outside air kit is available with this fireplace. For more details refer to section on outside air kit installation on page 3.

MINIMUM CLEARANCES TO COMBUSTIBLES:

- Back and sides of fireplace3/4" Min.
Note: the 3/4" clearance is not required at the nailing flanges
- Ceiling to Top of Opening 67-7/8" Min.
- Floor*0" Min.
*See step 2 of "Installing the Fireplace" below
- Wall to front of Fireplace36" Min.
- Perpendicular Wall to Opening of Unit14" Min.
- Top Spacers0" Min.
- Mantel Clearancessee page 7 "Finishing your Fireplace"
- Chimney Outer Pipe Surfaces1" Min.

WARNING: DO NOT PACK REQUIRED AIR SPACES WITH INSULATION OR OTHER MATERIALS.

MINIMUM/MAXIMUM CHIMNEY HEIGHT:

The MINIMUM height of the chimney, measured from the base of the fireplace to the flue gas outlet of the termination, is 11.5 feet for straight flue or a flue with one elbow set. The maximum distance between elbows is 2 feet. For systems with 2 elbow sets, the MINIMUM height is 22 feet. The maximum height of any system is 50 feet. This measurement includes the fireplace, chimney sections and the height of the termination assembly at the level of the flue gas outlet (see pg. 6, fig. 16).

FRAMING AND INSTALLING THE FIREPLACE

STEP 1: Frame the opening for the fireplace using the dimensions shown in figure 1 or 2.

STEP 2: If the fireplace is to be installed directly on carpeting, tile (other than ceramic), or any combustible material other than wood flooring; the fireplace must be installed upon a metal or wood panel extending the full width and depth of the fireplace.

STEP 3: Set the fireplace directly in front of this opening and slide the unit back until the nailing flanges touch the side framing.

STEP 4: Check the level of the fireplace and shim with sheet metal if necessary.

STEP 5: Before securing fireplace to prepared framing, the ember protector (provided), must be placed between the hearth extension (not supplied), and under the bottom front edge of the fireplace to protect against glowing embers falling through. If the fireplace is to be installed on a raised platform, a Z-type ember protector (not supplied) must be fabricated to fit your required platform height. The ember protector should extend under the fireplace a minimum of 1-1/2". The ember protector should be made of galvanized sheet metal (28ga. minimum) to prevent corrosion.

STEP 6: Using screws or nails, secure the fireplace to the framing through flanges located on the sides of the fireplace (see figure 4).

extension from shifting and seal the gap between the fireplace frame and hearth extension with a non-combustible material (see figure 3).

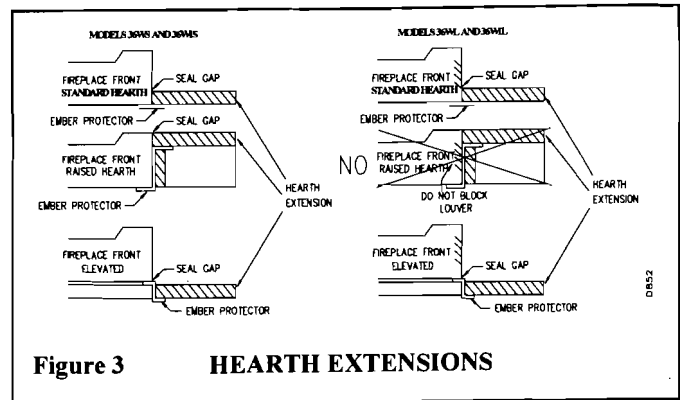

Figure 3 HEARTH EXTENSIONS

WARNING: HEARTH EXTENSION IS TO BE INSTALLED ONLY AS ILLUSTRATED.

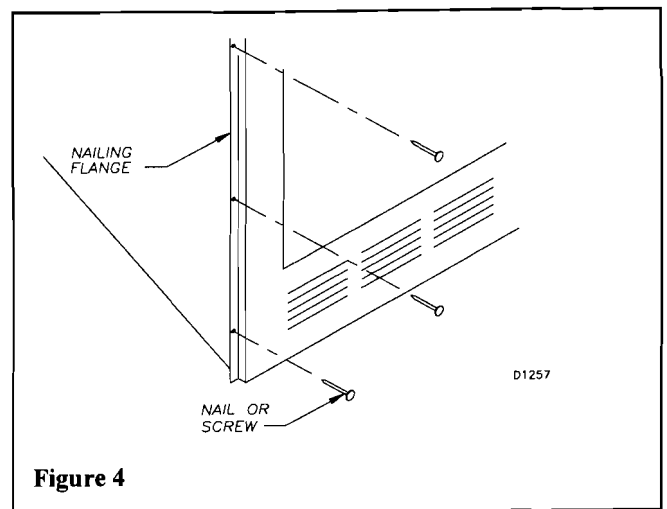

Figure 4

OPTIONAL OUTSIDE AIR KIT (MODEL AK4 / AK4F)
The installation of an outside air kit should be installed during the rough framing of the fireplace due to the nature of its location. Outside combustion air can be accessed through a vented crawl space (AK4F) or through a sidewall (AK4). See accessories on page 10 for details.

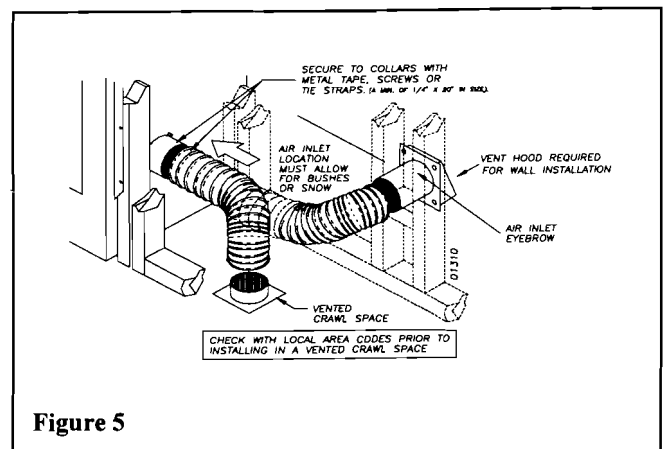

Figure 5

For more information, visit www.desatech.com

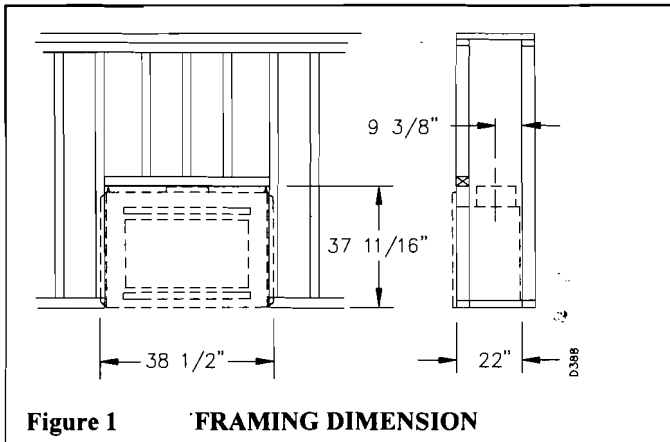

Figure 1 FRAMING DIMENSION

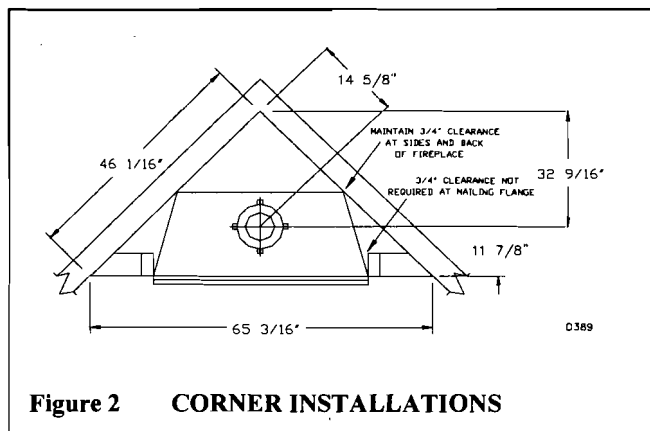

Figure 2 CORNER INSTALLATIONS

HEARTH EXTENSION:

A hearth extension projecting a minimum of 16" in front of and a minimum of 8" beyond each side of the fireplace opening is required to protect combustible floor construction in front of the fireplace. Fabricate a hearth extension using a material which meets the following specifications: a layer of non-combustible, inorganic material having a thermal conductivity of K=0.84 BTU IN/FT. HR. F (or less) at 1" thick. [For example, if the material selected has a K factor of 0.25, such as glass fiber, the following formula would apply. 0.25/0.84 x 1.0" = 0.30 thickness required. Thermal conductivity "K" of materials can be obtained from the manufacturer or supplier of the non-combustible material.] If the hearth extension is to be covered, use non-combustible material such as tile, slate, brick, concrete, metal, glass, marble, stone etc. Provide a means to prevent the hearth

FAN KIT ASSEMBLY: VCBK3E

A Fan Kit is optional (for Models W36C & IW36C only) with this fireplace. Use of blowers or fans other than manufactured by DESA voids the warranty. Fan is operated by simply pressing the rocker switch in the lower right corner of the fireplace face (see figure 6).

NOTE: Fireplace must be wired to the house electrical system in order for fan to operate. This fan system does not require a wall switch.

Electrical connections are made through the cover on the side of the fireplace illustrated in Figure 7. Use 14 AWG copper wire for all connections. Be certain the fireplace is properly grounded.

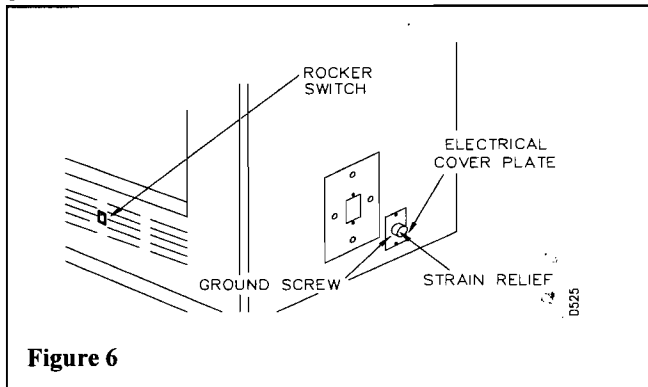

Figure 6

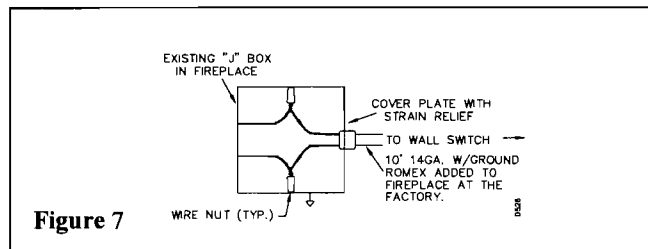

Figure 7

CHIMNEY PIPE

The DESA chimney system consists of 12, 18, 24, 36 and 48 inch, snap-lock double-wall pipe segments, planned for maximum adaptability to individual site requirements. Actual lengths gained after fitting overlaps must be taken into consideration (lineal gain) and are given in the following chart:

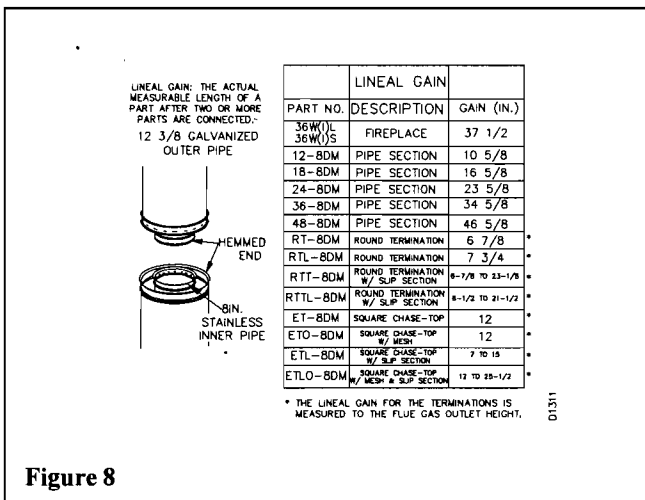

Figure 8

ASSEMBLING AND INSTALLING THE DOUBLE WALL CHIMNEY SYSTEM

Each double wall chimney section consists of a galvanized outer pipe, a stainless steel inner flue pipe and a wire spacer. The pipe sections must be assembled independently as the chimney is installed. When starting chimney directly to the fireplace, the inner flue pipe section must be installed first with the lanced side up. The outer pipe section can then be installed over the flue pipe section with the hemmed end up. Press down on each pipe section until the lances securely engage the hem on the fireplace starter. The wire will assure the proper spacing between the inner and outer pipe sections.

WARNING: The opening in the collar around the chimney at the top of the fireplace must not be obstructed. Never use blown insulation to fill the chimney enclosure.

Continue to assemble chimney sections as outlined above, making sure that both the inner and outer pipe sections are locked together. When installing double wall "snap lock" chimney together, it is important to assure the joint between the chimney sections is locked. Check by pulling chimney upward after locking. The chimney will not come apart if properly locked. It is not necessary to add screws to keep the chimney together (Exception - see page 5 figure 10).

INSTRUCTIONS WHEN ELBOW OFFSET OF CHIMNEY IS NEEDED: (30E-8DM)

TO INSTALL ELBOWS

- To achieve desired offset, you may install combinations of 12", 18", 24", 36" and 48" length of double wall pipe (SEE SINGLE OFFSET CHART, FIGURE 9 & 11).

OFFSET CHART (22-50 FT. SYSTEM HEIGHT)

OFFSET	RISE	CHIMNEY LENGTH				
		48"	36"	24"	18"	12"
4 - 3/8	16 - 3/8	ELBOW SET ONLY				
9 - 3/4	25 - 1/2					1
12 - 3/4	30 - 3/4				1	
15	34 - 3/4			1		
18	40				1	1
21 - 1/4	46 - 1/4		1			
23 - 3/4	49 - 1/4			1	1	
27 - 3/4	56 - 3/4	1				
30	60 - 3/4		1		1	
33	66	1				1
36	71	1			1	
38 - 1/4	75		2			
41 - 1/4	80 - 1/4		1		1	1
45	86 - 3/4		2			
46 - 3/4	89 - 1/2	1			1	1
51	97	1	1			
53 - 1/4	101		2		1	
56 - 1/4	106 - 1/4	2				
59 - 1/4	111 - 1/2	1	1		1	
61 - 3/4	115 - 1/2	2				1
64 - 3/4	120 - 3/4	2			1	
68 - 1/4	127	1	2			
70	130	2			1	1
74 - 1/4	137 - 1/2	1	2			1
76 - 3/4	141 - 1/2	1	2		1	
79 - 3/4	146 - 3/4		4			

- Chimney weight above offset rests on return elbow. Straps must be securely nailed to rafters or joists (see figure 9, details a & b).
- Maximum length of pipe between supports (return elbow or 12S-8DM) is 6' of angled run. Maximum of two (2) 6' angled run sections per chimney system (see figure 11).

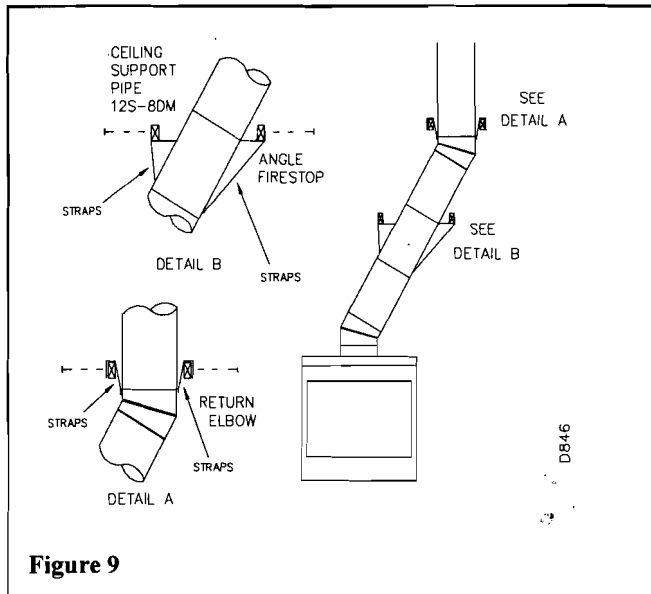

Figure 9

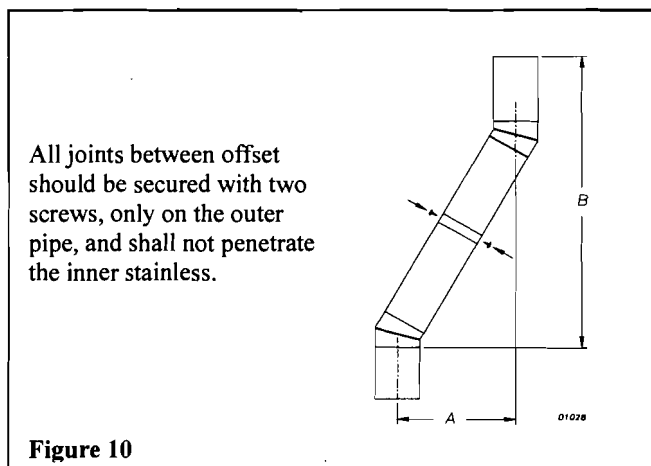

Figure 10

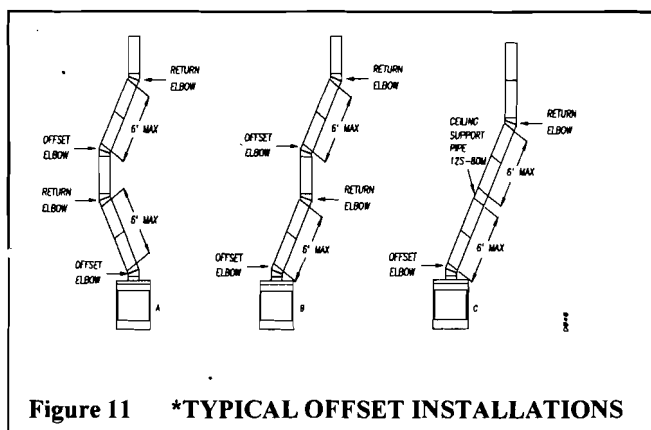

Figure 11 *TYPICAL OFFSET INSTALLATIONS

*For systems with 2 elbow sets, the minimum height is 22 ft. The maximum height for any system is 50 ft.

FIRESTOP SPACERS: (V3600FS-8DM)

Firestop spacers are required at each point where the chimney penetrates a floor space. Their purpose is to establish and maintain the required clearance between the chimney and the combustible materials. When the pipe passes through a framed opening into a living space above, the firestop must be placed onto the ceiling from below as shown in figure 12.

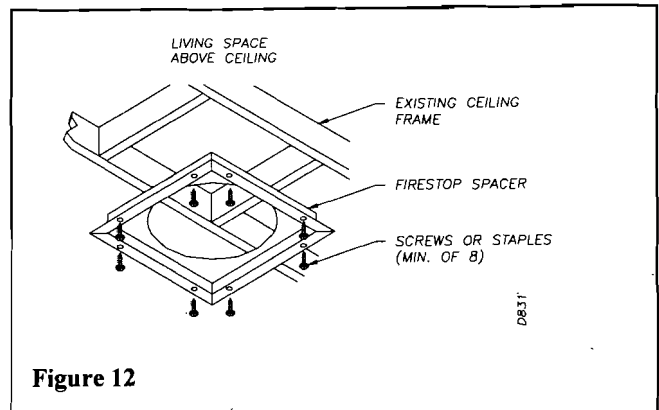

Figure 12

PENETRATING THE ROOF:

To maintain a 1-inch clearance to the pipe on a roof with a pitch, a rectangular opening must be cut.

STEP 1: Determine the center point through which the pipe will penetrate the roof.

STEP 2: Determine the center point of the roof. Pitch is the distance the floor drops over a given span, usually 12 inches. A 6/12 pitch means that the roof drops 6 inches for each 12 inches one measure horizontally down the roof.

STEP 3: Use the roof-opening chart (figure 13) below to determine the correct opening length and flashing required.

STEP 4: Remove the shingles around the opening measured and cut out this section.

STEP 5: Add the next sections of the pipe until the end penetrates the roofline. Check to see that the proper clearances are maintained. Extend chimney by adding sections of double wall pipe until pipe is a minimum of 30 inches above the highest point of the roof cutout. Termination and chimney must extend a minimum of 36 inches above the highest point where it passes through roof.

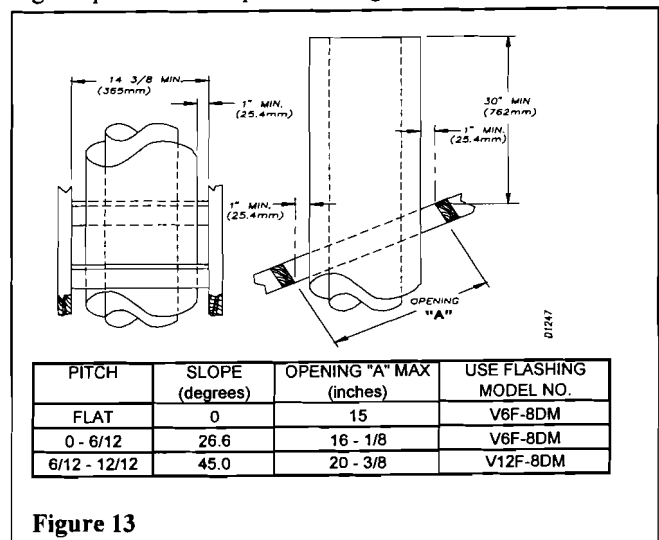
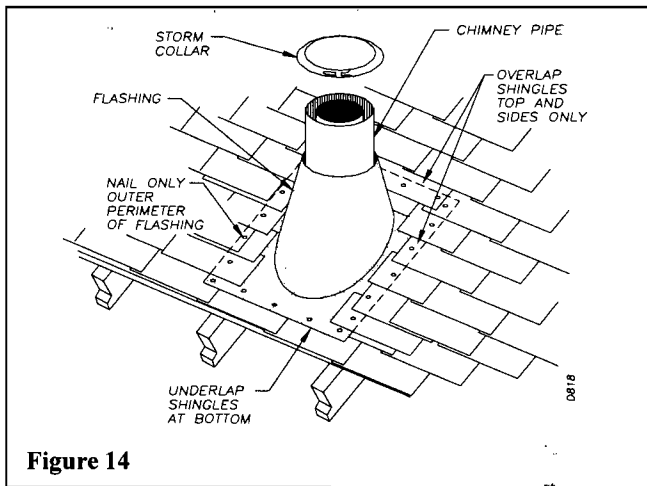

Figure 13

FLASHING INSTALLATION: (V6F-8DM or V12F-8DM)

Determine the flashing to be used with the roof-opening chart. Slide flashing over pipe until base is flat against roof. Replace as many shingles as needed to cover exposed area and flashing base. Secure in position by nailing through shingles (see figure 14).

DO NOT NAIL THROUGH FLASHING CONE.



INSTALLING FLASHING ON A METAL ROOF:

When installing the flashing on a metal roof it is required that putty tape be used between the flashing and the roof. The flashing must be secured to the roof using #8 x 3/4" screws and then sealed with roof coating to prevent leakage through the screw holes. A roof coating must also be applied around the perimeter of the flashing to provide a proper seal.

STORM COLLAR INSTALLATION: (SC1 or SC2)

Place storm collar over pipe and slide down until it is snug against the open edge of the flashing (see figure 15). Use SC1 for all round terminations and SC2 for all terminations with slip sections.

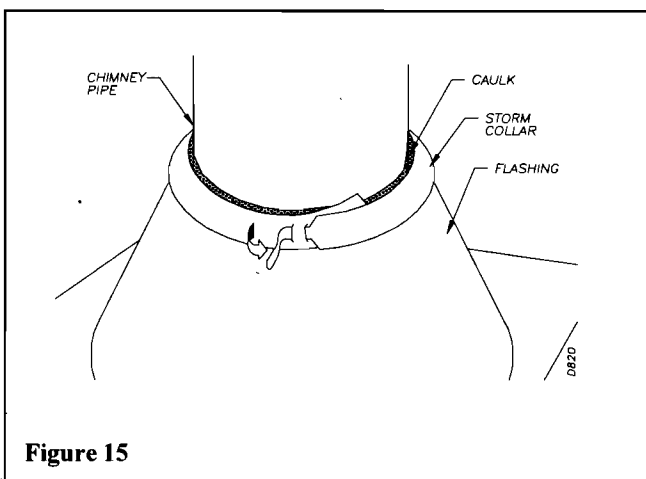

TERMINATIONS / SPARK ARRESTOR:

The fireplace system must be terminated with the listed round top or chase terminations. In any case, refer to the installation instructions supplied with the termination. The terminations approved for this fireplace are the RT-8DM and RTL-8DM

that can be used for flashing or chase and ET-8DM, ETO-8DM, ETL-8DM and ETLO-8DM for chase style termination only. Figure 16 shows an RTL-8DM round top termination.

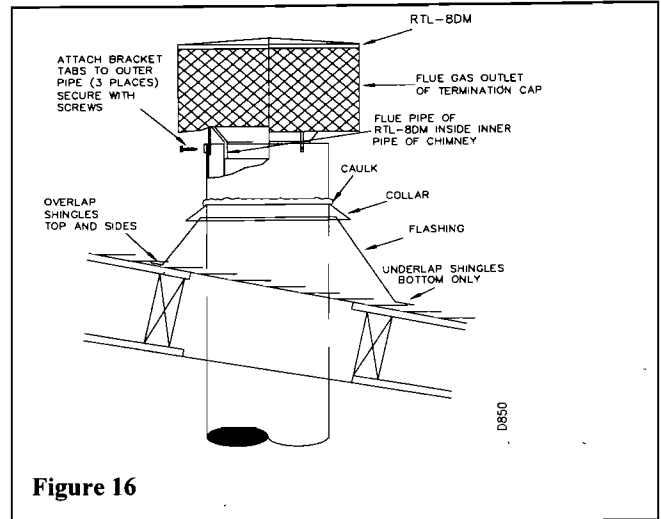

CAUTION: Do not seal openings on the rooftop flashing. Follow the installation instructions provided with the termination being used.

Terminations with 16" slip pipe sections are available. The RTT-8DM and RTTL-8DM are approved for flashing installations. When needed, these adjustable terminations may be used in combination with the pipe assembly to achieve the correct chimney height.

NOTE: In the rare instance there is a problem with side driven rain or wind or the chimney is not drafting properly, an ADS-8DM Anti Draft Shield can be used with round terminations.

CHASE INSTALLATIONS:

Instructions for chase installations are included with the chase style termination chosen. In a multiple chase installation, be sure to provide adequate distance between terminations to prevent smoke spillage from one termination to another. We suggest that terminations be separated at least 24 inches, center to center and stacked at vertical height difference of 18 inches (see figure 17).

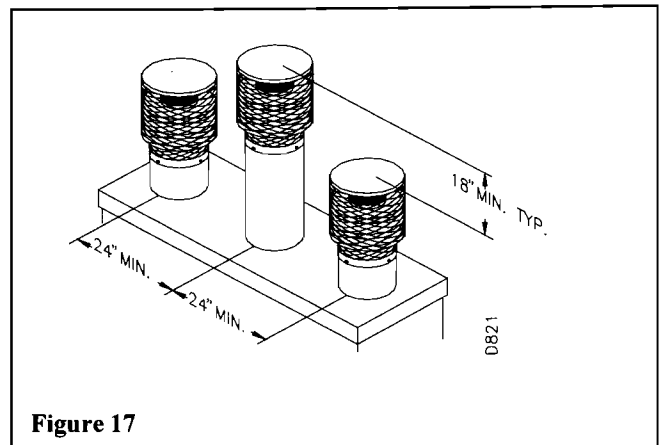

10 FOOT RULE:

All flue gas outlet of chimney termination must extend a minimum of 3 feet in height above the highest point where it passes through the roof and must be at least 2 feet above the highest point of the roof that is within a horizontal distance of 10 feet (see figure 18).

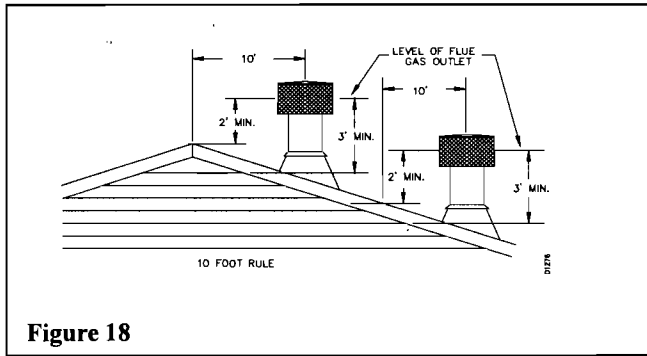

Figure 18

FINISHING THE FIREPLACE:

Combustible materials, such as wallboard, gypsum board, sheet rock, drywall, plywood, etc may make direct contact with sides and top periphery of the fireplace face. It is important that combustible materials do not overlap the face itself. Brick, glass, tile or other non-combustible materials may overlap the front face provided they do not obstruct essential openings like louvered slots or any other opening. When overlapping with a non-combustible facing material use only non-combustible mortar or adhesive.

MANTELS:

A mantel may be installed if desired (see figure 19). Woodwork such as wood trims, mantels, or any other combustible material projecting from the front face must not be placed within 9 inches of the fireplace opening (and within 6 inches of the top louver opening). Combustible materials above 9 inches and projecting more than 1-1/2 inches from the fireplace face must not be placed less than 12 inches from the top of the opening of the fireplace (NFPA STD 211, Sec. 7-3.3.3).

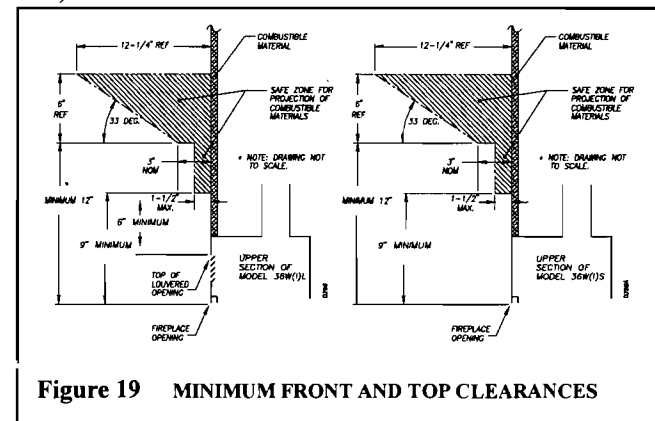

Figure 19 MINIMUM FRONT AND TOP CLEARANCES

Mantels or any other combustible materials such as wallboard, sheet rock, drywall, plywood, etc. butt up to the side of the black metal face of the fireplace. The clearances from the side of the fireplace to any combustible material and wall should fall within the limits shown in figure 20.

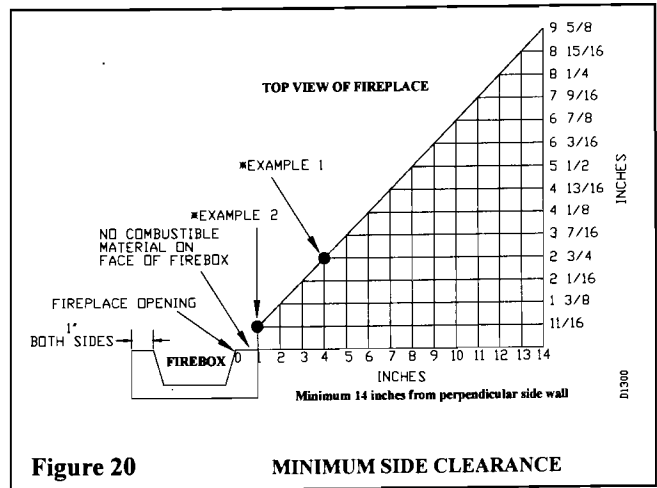

Figure 20

MINIMUM SIDE CLEARANCE

*Example 1 (figure 20): The face of a mantel, bookshelf, etc. is made of combustible materials and protrudes 2-3/4" from the wall the fireplace is installed in. This combustible material must be a minimum of 4" from the side of the fireplace opening.

*Example 2 (figure 20): The face of a mantel, bookshelf, etc. is made of combustible materials and protrudes 11/16" from the wall the fireplace is installed in. This combustible material can butt up against the side of the fireplace (i.e. 1" from the fireplace opening).

OPERATING GUIDELINES AND MAINTENANCE INSTRUCTIONS

GLASS DOORS

Glass doors are optional with the fireplace. When the fireplace is in operation, doors must be in the FULLY OPEN or FULLY CLOSED position only or a fire hazard may be created (see figure 21).

A fireplace equipped with glass doors operates much differently than a fireplace with an open front. A fireplace with glass doors has a limited amount of air for combustion. Excessive heat within the fireplace can result if too large a fire is built or if the combustion air gate is not completely open. The following tips should be followed to assure that both the fireplace and the glass door retain their beauty and function properly. Both flue damper and the glass doors must be fully open before starting the fire. This will provide sufficient combustion air and maintain safe temperatures in the firebox.

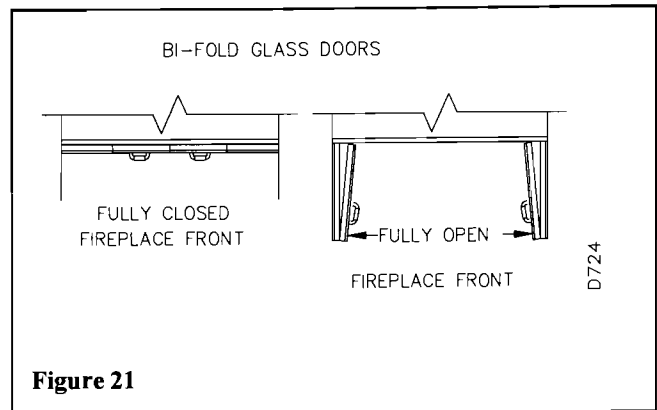

Figure 21

IMPORTANT: The glass must be allowed to warm slowly and evenly. The tempered glass will withstand a gradual temperature rise to 550 degrees Fahrenheit, which is more than a normal fire will generate. Such materials as pitch/wax laden logs, very dry mill end lumber, and large amounts of paper or cardboard boxes can create an excessively hot fire and should not be burned in this fireplace. Always keep the fire well back from the doors and never allow flames to contact the glass.

WARNING: Fireplaces equipped with glass doors should be operated only with door fully opened or doors fully closed. Doors, if left partly open, may draw gas and flame out of the fireplace opening creating risks of both fire and smoke.

CLEANING THE GLASS: Clean the glass with any commercial glass cleaner or soap and water. **DO NOT** use any abrasive material to clean the glass. **DO NOT** clean the glass with any cool water if the glass is still hot from the fire.

OPTIONAL GAS LINE INSTALLATION

GAS LINE HOOK UP SHOULD BE DONE BY YOUR SUPPLIER OR A QUALIFIED SERVICE PERSON.

NOTE: BEFORE YOU PROCEED, MAKE SURE YOUR GAS SUPPLY IS TURNED OFF.

A gas line may be installed for the purpose of installing a vented or vent-free gas appliance available through your local distributor. Use only 1/2 inch black iron pipe and appropriate fittings. When installing a gas line, a shut-off valve designed for installation outside the appliance is recommended.

STEP 1: To install, remove the knockout indentation on the refractory, (or firebrick), wall located approximately 2 inches above the refractory hearth floor. The knockout indentation must be firmly tapped with any solid object until it is released. Remove fragmented portions of refractory (see figure 22).

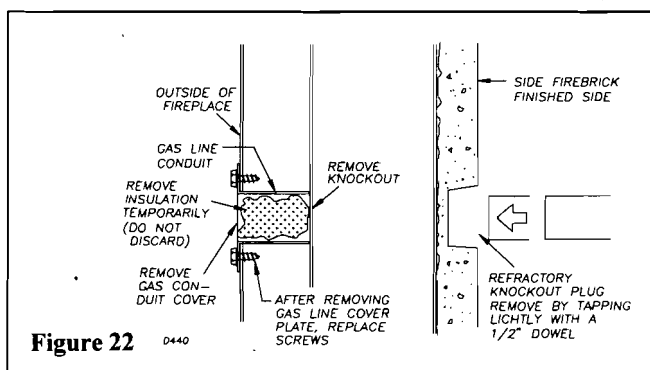

Figure 22 0440

STEP 2: Remove gas line cover plate on rear of fireplace and pull out insulation from gas line conduit sleeve. Save insulation for reuse.

STEP 3: Run a 1/2 inch black iron gas line into the fireplace through the gas line conduit sleeve. Provide sufficient gas line into fireplace chamber for fitting connection (see figure 23).

NOTE: Secure incoming gas line to wood framing to provide rigidity for threaded end.

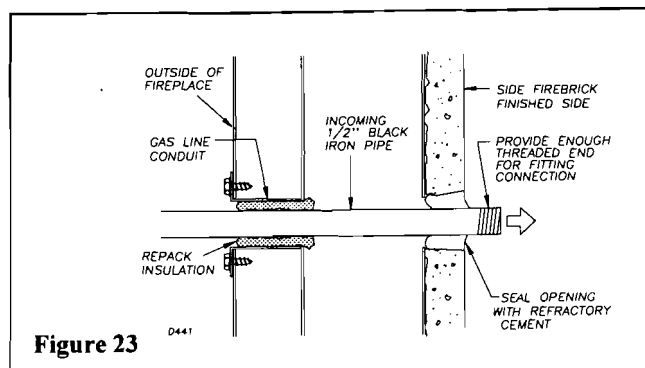

Figure 23 0441

STEP 4: Repack insulation around gas line and into sleeve opening. Seal any gaps between gas line and refractory knockout hole with refractory cement or commercial furnace cement. Install the gas appliance or cap-off gas line if desired.

The gas pipe is intended for connection to an unvented (vent-free) or a decorative gas appliance (vented gas log).

CAUTION: All gas piping and connections must be tested for leaks after the installation is completed. After ensuring that the gas valve is on, apply a soap and water solution to all connections and joints. Bubbles forming show a leak. Correct all leaks at once. **DO NOT USE AN OPEN FLAME FOR LEAK TESTING AND DO NOT OPERATE ANY APPLIANCE IF A LEAK IS DETECTED.**

If you wish to install an unvented (vent-free) gas log set, **ONLY UNVENTED GAS LOG SETS WHICH HAVE BEEN FOUND TO COMPLY WITH THE STANDARD FOR UNVENTED ROOM HEATERS, ANSI Z21.11.2, ARE TO BE INSTALLED IN THIS FIREPLACE.**

NOTE: A DESA hood must be installed when using an unvented gas log set (see accessories on page 10).

WARNING: DO NOT OPERATE AN UNVENTED GAS LOG SET IN THIS FIREPLACE WITH THE CHIMNEY REMOVED.

If you install a decorative gas appliance (vented gas log), the decorative gas appliance must comply with the **Standard for Decorative Gas Appliances for Installation in solid fuel burning Fireplaces, ANS Z21.60-1996, Z21.84 or RGA 2-72,** and shall also be installed in accordance with the **National Fuel Gas code, ANS Z223.1-1996.**

WARNING: If the fireplace has been used for wood burning, the firebox and chimney must be cleaned of soot, creosote and ashes by a qualified chimney cleaner. Creosote will ignite if highly heated.

WARNING: WHEN USING A DECORATIVE VENTED GAS LOG, THE DAMPER MUST BE REMOVED OR PERMANENTLY LOCKED IN THE FULLY OPENED POSITION.

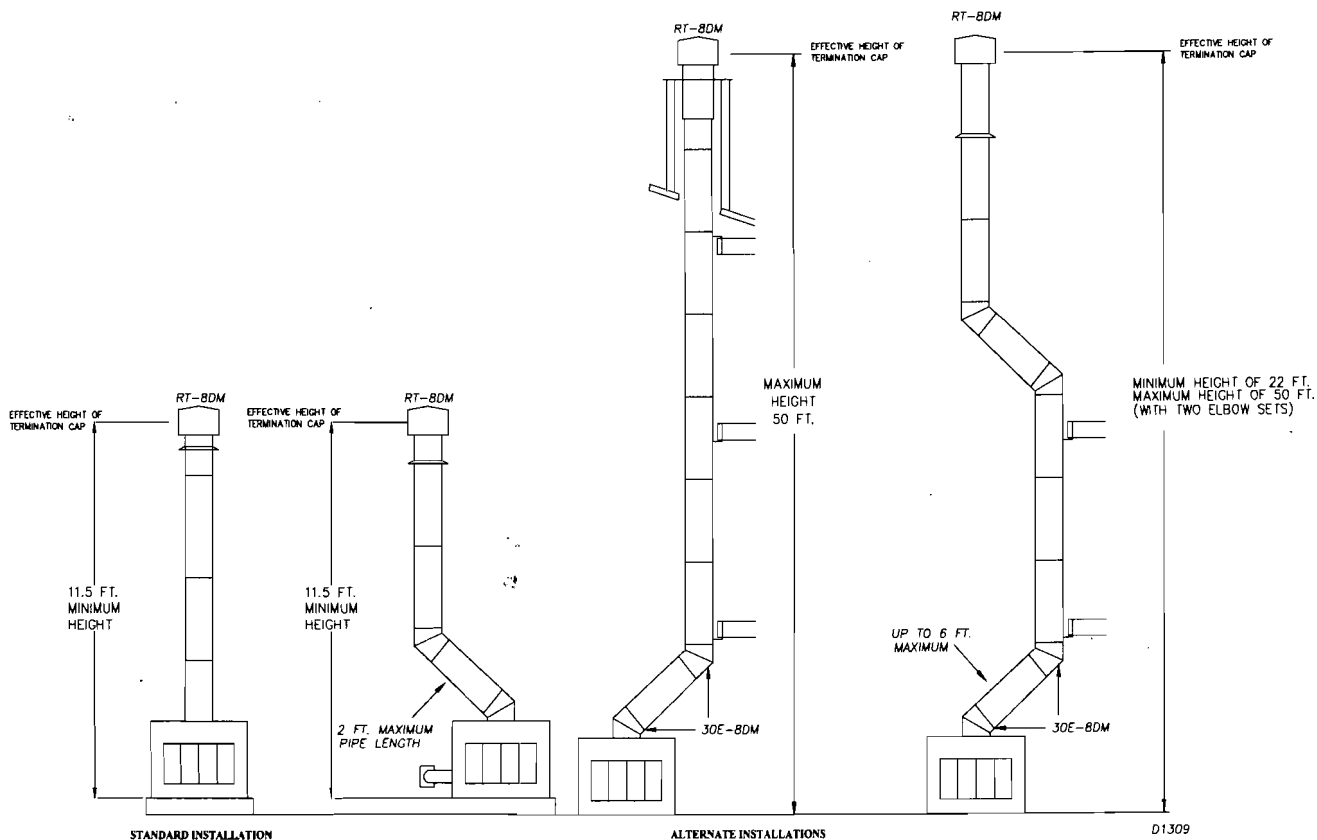

DAMPER OPERATION:

The damper handle to open and close the damper blade is located inside the firebox at the center towards the back wall. Pushing the handle back in the keyway slot will free the damper blade to automatically open. To close, reach in and push the handle back into the keyhole slot then pull down and forward to lock it in place (see figure 24).

WARNING: Risk of fire! Replace grate with DESA model 107001-01 grate only. This grate has been designed to keep the operation of your fireplace safe and efficient.

FOR FURTHER OPERATING GUIDELINES, INSTRUCTIONS AND WARRANTY INFORMATION PLEASE REFER TO YOUR HOMEOWNERS GUIDE OR CONTACT YOUR AUTHORIZED DEALER.

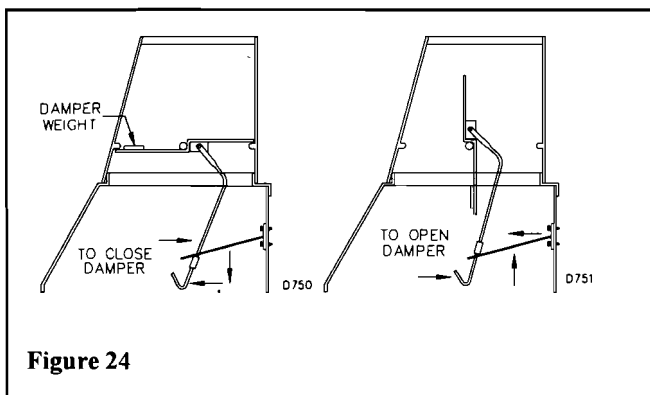

Figure 24

TECHNICAL SERVICE

You may have further questions about installation, operations, or troubleshooting. If so, contact The Technical Service Department at 1-888-427-8322. When calling, have the model number of the fireplace ready.