

# LENNOX®

HEARTH PRODUCTS

## INSTALLATION INSTRUCTIONS

### B-VENT GRDE-8038/8043

B-VENTED GAS FIREPLACES  
P/N 850,009M REV. A 11/2001

This appliance may be installed in an after-market permanently located, manufactured home (USA only) or mobile home, where not prohibited by local codes. This appliance is only for use with the type of gas indicated on the rating plate. This appliance is not convertible for use with other gases, unless a certified kit is used.

### MODELS

<i>Millivolt Models</i>	<i>Electronic Models</i>
GRDE-8038N	GRDE-8038NE-2
GRDE-8038P	GRDE-8038PE-2
GRDE-8043N	GRDE-8043NE-2
GRDE-8043P	GRDE-8043PE-2

RETAIN THESE INSTRUCTIONS  
FOR FUTURE REFERENCE

Warnock Hersey



WH Report No. J20037762

**WARNING: IF THE INFORMATION IN THIS MANUAL IS NOT FOLLOWED EXACTLY, A FIRE OR EXPLOSION MAY RESULT CAUSING PROPERTY DAMAGE, PERSONAL INJURY OR LOSS OF LIFE.**

**FOR YOUR SAFETY:** Do not store or use gasoline or other flammable vapors or liquids in the vicinity of this or any other appliance.

**FOR YOUR SAFETY:** What to do if you smell gas:

- DO NOT light any appliance.
- DO NOT touch any electrical switches.
- DO NOT use any phone in your building.
- Immediately call your gas supplier from a neighbor's phone.

Follow your gas suppliers instructions.

- If your gas supplier cannot be reached, call the fire department.

Installation and service must be performed by a qualified installer, service agency or the gas supplier.

**AVERTISSEMENT: ASSUREZ-VOUS DE BIEN SUIVRE LES INSTRUCTIONS DONNÉES DANS CETTE NOTICE POUR RÉDUIRE AU MINIMUM LE RISQUE D'INCENDIE OU POUR ÉVITER TOUT DOMMAGE MATÉRIEL, TOUTE BLESSURE OU LA MORT.**

**POUR VOTRE SÉCURITÉ:** Ne pas entreposer ni utiliser d'essence ni d'autre vapeurs ou liquides inflammables dans le voisinage de cet appareil ou de tout autre appareil.

**POUR VOTRE SÉCURITÉ:** Que faire si vous sentez une odeur de gaz:

- Ne pas tenter d'allumer d'appareil.
- Ne touchez à aucun interrupteur. Ne pas vous servir des téléphones se trouvant dans le bâtiment où vous vous trouvez.
- Evacuez la pièce, le bâtiment ou la zone.
- Appelez immédiatement votre fournisseur de gaz depuis un voisin. Suivez les instructions du fournisseur.
- Si vous ne pouvez rejoindre le fournisseur de gaz, appelez le service des incendies.

L'installation et service doit être exécuté par un qualifié installer, agence de service ou le fournisseur de gaz.

## TABLE OF CONTENTS

Packaging .....	page 2
Introduction .....	page 2
General Information .....	page 2
Location .....	page 3
Appliance Specifications .....	page 4
Gas Vent Rule .....	page 4
Clearances .....	page 5
Framing Specifications .....	page 5
Typical Installation Sequence .....	page 6
Installation .....	page 7
Venting System Installation .....	page 7
Field Wiring .....	page 8
Connecting Gas Line .....	page 9
Outside Air Kit Installation .....	page 9
Log, Rockwool, Vermiculite or Sand Installation .....	page 10
Appliance Operation .....	page 10
Millivolt Appliance Checkout .....	page 10
Electronic Appliance Checkout .....	page 10
Spillage Test and Safety Limit Switch Operation .....	page 10
Finishing Requirements .....	page 11
Cold Climate Insulation .....	page 11
Installation Accessories .....	page 12
Gas Conversion Kits .....	page 13

This installation manual will help you obtain a safe, efficient, dependable installation for your appliance and vent system.

**Please read and understand these instructions before beginning your installation.**

### PACKAGING

The assembled vented gas fireplace is packaged with:

- 1 - one cartoned log set located in firebox area. A bag of vermiculite (Propane Gas units), or a bag of sand (Natural gas units) located on the right side top of the unit.
- 2 - one bag of glowing embers (rockwool) located inside of the firebox in front of the burner.
- 3 - one extension bar for outside air damper actuator located in the firebox in front of the burner.
- 4 - one envelope containing the literature package which consists of the homeowner's manual, installation instructions, and warranty; envelope is located in the control area.
- 5 - one B-Vent Connector taped to the left side top of the unit.

## INTRODUCTION

The GRDEN, P models are radiant heat system appliances. The millivolt versions of these appliances are designed to operate on either natural or propane gas. A millivolt gas control valve with piezo ignition system provides safe, efficient operation. There is no need for external power to operate these appliances.

The GRDE NE-2, PE-2 models are radiant heat system appliances. The electronic versions of these appliances are designed to operate on either natural or propane gas. An electronic intermittent pilot system provides safe, efficient operation. External electrical power is required to operate these units.

**A front glass enclosure panel is factory installed in the appliance. The enclosure panel must be in place when the fireplace is in operation. Failure to do so, may affect the product warranty.**

These appliances comply with National Safety Standards and are tested and listed by Warnock Hersey (Report No. J20037762) to ANSI Z21.50 - 2000 (in Canada, CSA 2.22 - 2000), and CAN/CGA-2.17-M91 in both USA and Canada, as vented gas fireplaces.

Installation must conform to local codes. In the absence of local codes, installation must comply with the current National Fuel Gas Code, ANSI Z223.1 (NFPA 54). (In Canada, the current CAN/CGA B149 installation code.) Electrical wiring must comply with local codes. In the absence of local codes, installation must be in accordance with the National Electrical Code, NFPA 70 - (latest edition). (In Canada, the current CSA C22.1 Canadian Electric Code.)

**DO NOT ATTEMPT TO ALTER OR MODIFY THE CONSTRUCTION OF THE APPLIANCE OR ITS COMPONENTS. ANY MODIFICATION OR ALTERATION MAY VOID THE WARRANTY, CERTIFICATION AND LISTINGS OF THIS UNIT.**

**WARNING: IMPROPER INSTALLATION, ADJUSTMENT, ALTERATION, SERVICE OR MAINTENANCE CAN CAUSE INJURY OR PROPERTY DAMAGE. REFER TO THIS MANUAL. FOR ASSISTANCE OR ADDITIONAL INFORMATION CONSULT A QUALIFIED INSTALLER, SERVICE AGENCY OR THE GAS SUPPLIER.**

NOTE: DIAGRAMS & ILLUSTRATIONS NOT TO SCALE.

## GENERAL INFORMATION

*Note: Installation and repair should be performed by a qualified service person. The appliance should be inspected annually by a qualified professional service technician. More frequent inspections and cleanings may be required due to excessive lint from carpeting, bedding material, etc. It is imperative that the control compartment, burners and circulating air passage ways of the appliance be kept clean.*

*S'assurer que le brûleur et le compartiment des commandes sont propres. Voir les instructions d'installation et d'utilisation qui accompagnent l'appareil.*

Provide adequate clearances around air openings and adequate accessibility clearance for service and proper operation. Never obstruct the front openings of the appliance.

**WARNING: THESE FIREPLACES ARE VENTED DECORATIVE GAS APPLIANCES. DO NOT BURN WOOD OR OTHER MATERIAL IN THESE APPLIANCES.**

These appliances are designed to operate on natural or propane gas only. The use of other fuels or combination of fuels will degrade the performance of this system and may be dangerous.

Input of appliance is 45,000 BTU/HR.

Gas Type	Orifice Size	Elevation
Natural	(#30)	0 - 4500' (0 - 1370 m)
Propane	(#46)	0 - 4500' (0 - 1370 m)

Nominal operating pressures for the manifold side of the gas control system are; 3.5 inches water column (6.54 MmHg) for natural gas models and 10 inches water column (18.69 MmHg) for propane gas models.

Do not use these appliances if any part has been under water. Immediately call a qualified, professional service technician to inspect the appliance and to replace any parts of the control system and any gas control which have been under water.

Ne pas se servir de cet appareil s'il a été plongé dans l'eau, complètement ou en partie. Appeler un technicien qualifié pour inspecter l'appareil et remplacer toute partie du système de contrôle et toute commande qui ont été plongés dans l'eau.

Appliances may be fitted at the time of manufacture with either a Honeywell millivolt gas control valve or a Honeywell electronic gas control valve. They have been tested with and approved for use with these appliances and are listed accordingly.

Test gage connections are provided on the front of the Honeywell millivolt gas control valves (identified OUT for the manifold side and IN for inlet pressure side. A 1/8" NPT test gage connection is provided on the Honeywell electronic gas control valve adjacent to the outlet to the main burner.

Minimum inlet gas pressure to the appliance is 5.0 inches water column (1.24 kPa) for natural gas and 11 inches water column (2.74 kPa) for propane for the purpose of input adjustment.

Maximum inlet gas supply pressure to the appliance is 10.5 inches water column (2.61 kPa) for natural gas and 13.0 inches water column (3.23 kPa) for propane.

The appliance must be isolated from the gas supply piping system (by closing its individual manual shut-off valve) during any pressure testing of the gas supply piping system at test pressures equal to or less than 1/2 psig (3.5 kPa).

The appliance and its individual shut-off valve must be disconnected from the gas supply piping system during any pressure testing of that system at pressures in excess of 1/2 psig (3.5 kPa).

These appliances must not be connected to a chimney or flue serving a separate solid fuel burning appliance.

Do not place clothing or other materials on or near this appliance.

This appliance may be installed in an aftermarket permanently located, manufactured home (USA only) or mobile home, where not prohibited by local codes. This appliance is only for use with the type of gas indicated on the rating plate. This appliance is not convertible for use with other gases, unless a certified kit is used.

Cet appareil peut être installé dans un maison préfabriquée (É.-U. seulement) ou mobile déjà installée à demeure si les règlements locaux le permettent.

Cet appareil doit être utilisé uniquement avec les types de gaz indiqués sur la plaque signalétique. Ne pas l'utiliser avec d'autres gaz sauf si un kit de conversion certifié est installé.

**WARNING: FAILURE TO COMPLY WITH THE INSTALLATION AND OPERATING INSTRUCTIONS PROVIDED IN THIS DOCUMENT WILL RESULT IN AN IMPROPERLY INSTALLED AND OPERATING APPLIANCE, VOIDING ITS WARRANTY. ANY CHANGE TO THIS APPLIANCE AND/OR ITS OPERATING CONTROLS IS DANGEROUS. IMPROPER INSTALLATION OR USE OF THIS APPLIANCE CAN CAUSE SERIOUS INJURY OR DEATH FROM FIRE, BURNS, EXPLOSION OR CARBON MONOXIDE POISONING.**

**Carbon Monoxide Poisoning:** Early signs of carbon monoxide poisoning are similar to the flu with headaches, dizziness and/or nausea. If you have these signs, obtain fresh air immediately. Turn off the gas supply to the appliance and have it serviced by a qualified professional, as it may not be operating correctly.

**WARNING: B-VENT APPLIANCES ARE NOT DESIGNED TO OPERATE IN NEGATIVELY PRESSURED ENVIRONMENTS (PRESSURE WITHIN THE HOME IS LESS THAN PRESSURES OUTSIDE). SIGNIFICANT NEGATIVELY PRESSURED ENVIRONMENTS CAUSED BY WEATHER, HOME DESIGN, OR OTHER DEVICES MAY IMPACT THE OPERATION OF THESE APPLIANCES. NEGATIVE PRESSURES MAY RESULT IN POOR FLAME APPEARANCE, SOOTING, DAMAGE TO PROPERTY AND/OR SEVERE PERSONAL INJURY. DO NOT OPERATE THESE APPLIANCES IN NEGATIVELY PRESSURED ENVIRONMENTS. PROVIDING ADEQUATE VENTILATION TO THE APPLIANCE FOR COMBUSTION AIR WILL ELIMINATE A NEGATIVE PRESSURE ENVIRONMENT.**

**WARNING: CHILDREN AND ADULTS SHOULD BE ALERTED TO THE HAZARDS OF HIGH SURFACE TEMPERATURES. USE CAUTION AROUND THE APPLIANCE TO AVOID BURNS OR CLOTHING IGNITION. YOUNG CHILDREN SHOULD BE CAREFULLY SUPERVISED WHEN THEY ARE IN THE SAME ROOM AS THE APPLIANCE.**

**WARNING: DO NOT PLACE CLOTHING OR OTHER FLAMMABLE MATERIALS ON OR NEAR THIS APPLIANCE.**

NOTE: DIAGRAMS & ILLUSTRATIONS NOT TO SCALE.

**AVERTISSEMENT: SURVEILLER LES ENFANTS. GARDER LES VÊTEMENTS, LES MEUBLES, L'ESSENCE OU AUTRES LIQUIDES À VAPEUR INFLAMMABLES LOIN DE L'APPAREIL.**

**WARNING: THIS APPLIANCE MAY ONLY BE FITTED WITH THE DOOR CERTIFIED FOR USE WITH THE APPLIANCE.**

**AVERTISSEMENT: POUR UTILISATION UNIQUEMENT AVEC LE PORTE EN VERRE CERTIFIÉES AVEC L'APPAREIL.**

These appliances are equipped with an integral combustion air door and actuator arm. Combustion air kits are optional. Install as shown in Step 7 on page 9.

#### LOCATION

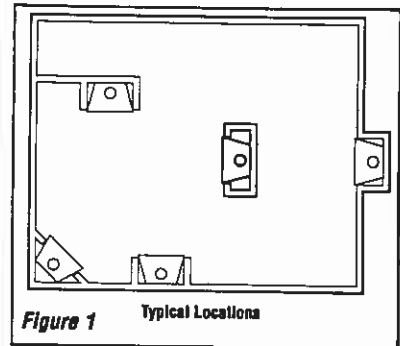

In selecting the location, the aesthetic and functional use of the appliance are primary concerns. However, vent system routing to the exterior and access to the fuel supply are also important. Due to high temperatures the appliance should be located out of traffic and away from furniture and draperies. Consideration should be given to traffic ways, furniture, draperies, etc., due to elevated surface temperatures. The location should also be free of electrical, plumbing or other heating/air conditioning ducting.

The appliance should be mounted on a fully supported base extending the full width and depth of the unit. The appliance may be located on or near conventional construction materials. However, if installed on combustible materials, such as carpeting, vinyl tile, etc., a metal or wood barrier covering the entire bottom surface must be used.

These appliances may be used for bedroom installations in the United States and are listed accordingly. These units may not be installed in bedrooms in Canada.

# APPLIANCE SPECIFICATIONS

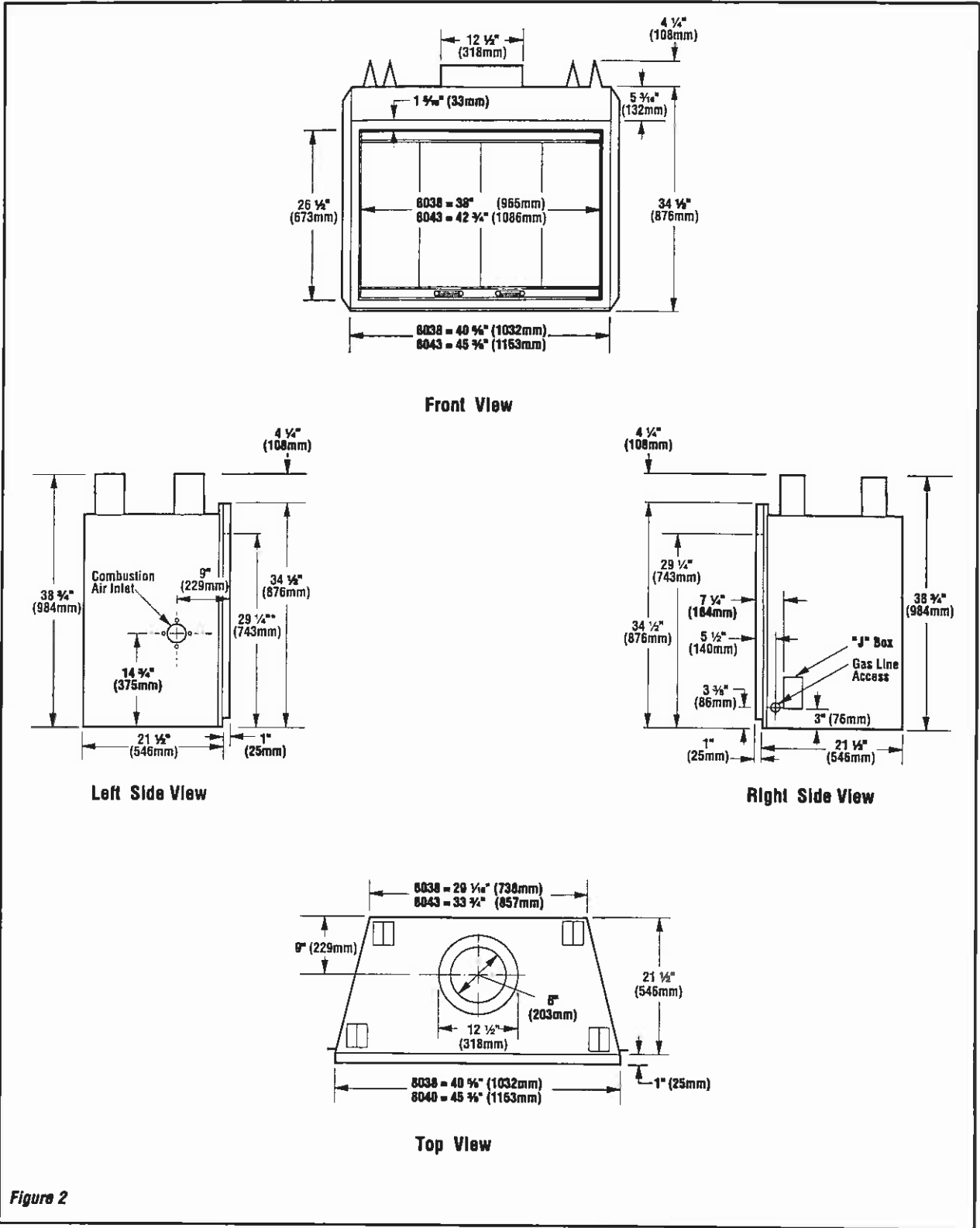
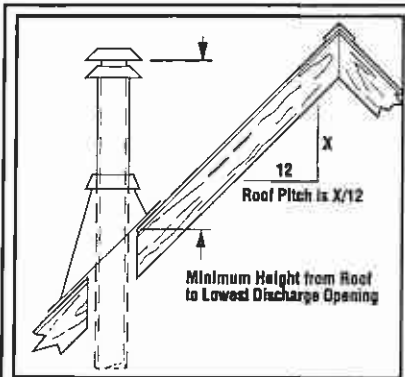

Figure 2

NOTE: DIAGRAMS & ILLUSTRATIONS NOT TO SCALE.

## Venting

**Gas Vent Rule** – Gas vent caps are not permitted within 8 feet (2.4 mm) of a vertical wall or similar obstruction. Gas vent caps that are located 8' or more from a portion of a building which extends at an angle greater than 45° upward from the horizontal may terminate in accordance with the table in **Figure 3**, provided that in no case shall any discharge opening on the cap be less than 2' (610 mm) horizontally from the roof surface (National Fuel Gas Code ANSI Z223.1 (NFPA 54) 7.6.2) (CAN/CGA B149).



Roof Slope	Minimum Height from Roof to Lowest Discharge Opening	
	Feet	Meters
Flat to 6/12	1' 0"	0.3
Over 7/12 to 9/12	2' 0"	0.6
Over 10/12 to 12/12	4' 0"	1.2
Over 13/12 to 16/12	6' 0"	1.8
Over 17/12 to 21/12	8' 0"	2.4

**Note:** Venting terminals shall not be recessed into a wall or siding.

**Figure 3**

## APPLIANCE CLEARANCES

	GRDE-8038/8043
Back	1/2 in. (13mm)
Sides	1/2 in. (13mm)*
Top Spacers	0 in. (0 mm)
Floor	0 in. (0 mm)
From Bottom of Unit to Ceiling	64 in. (1626 mm)
Vent	1 in. (25.4 mm)
<b>SERVICE CLEARANCE</b>	
Front	3 Feet (0.9 meters)

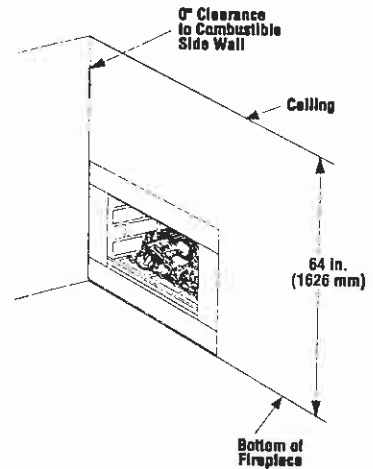

\*Note: The nailing tabs and the area directly behind the nailing tabs are exempt from the clearances described in the above table. See **Figure 9** on page 7.

\*\*Note: See also **Figure 25** on page 11 for an illustration of mantel clearances.

**Figure 4**

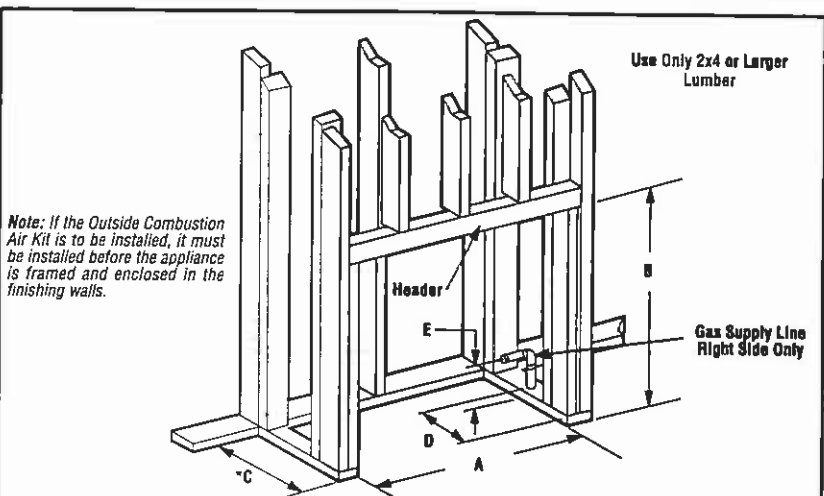

\*Note: The framed depth - dimension "C" - from a framed wall, must always be measured from a finished surface. If a wall covering such as drywall is to be attached to the rear wall, then dimension "C" must be measured from the drywall surface. It is important that this dimension be exact.

Model No.		A	B	C	D	E
GRDE-8038	in.	40 3/4	39	21 3/8	4 1/2	3 3/8
	mm	1035	991	543	114	86
GRDE-8043	in.	45 7/8	39	21 3/8	4 1/2	3 3/8
	mm	1165	991	543	114	86

**Figure 5**

NOTE: DIAGRAMS & ILLUSTRATIONS NOT TO SCALE.

## FRAMING SPECIFICATIONS CONTINUED

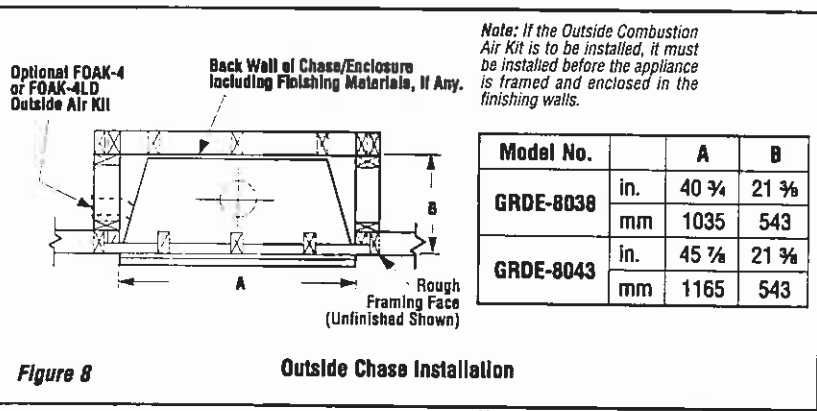
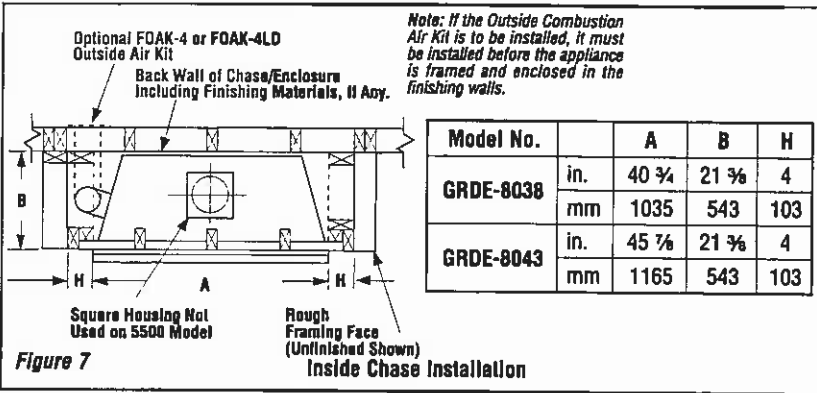
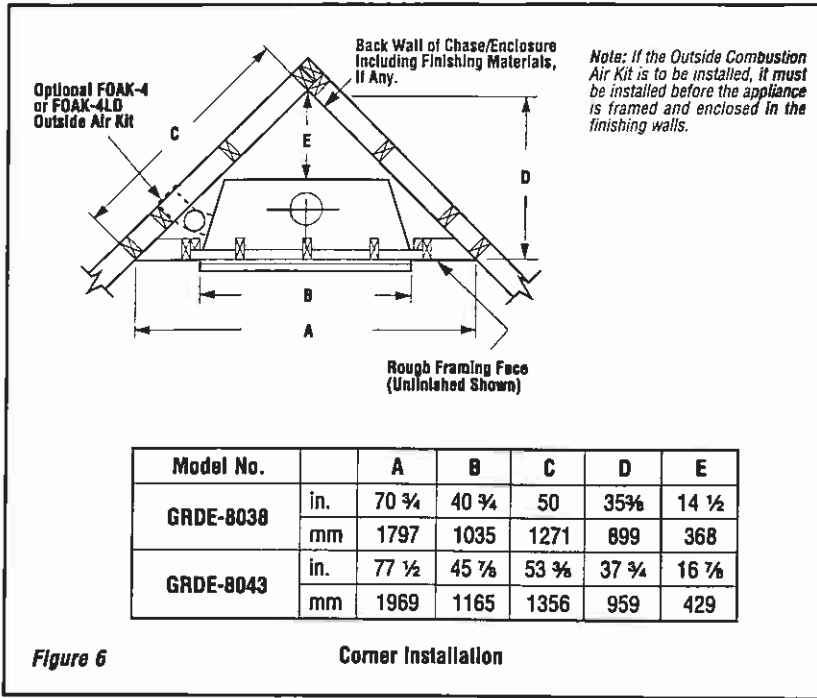

## TYPICAL INSTALLATION SEQUENCE

The typical sequence of installation follows, however, each installation is unique resulting in variations to those described.

1. Construct the appliance framing.
2. Route gas supply line to appliance location.
3. Position the appliance.
4. Install the vent system and exterior termination.
5. Field wire and install operating control switch.
6. Make connection to gas supply.
7. Install optional Outside Combustion Air Kit, if required.
8. Install the logs and rockwool, with vermiculite (propane units) or sand (natural gas units)
9. Checkout appliance operation.
10. Install front glass enclosure panel.
11. Spillage Test and Safety Limit Switch Operation.

## PRE-INSTALLATION NOTES

The fireplace may be installed directly on a combustible floor or raised on a platform of an appropriate height. Do not place fireplace on carpeting, vinyl or other soft floor coverings. It may, however, be placed on flat wood, plywood, particle board or other hard surfaces. Be sure fireplace rests on a solid continuous floor or platform with appropriate framing for support and so that no cold air can enter the room from under the fireplace.

The fireplace may be positioned and then the framing built around it, or the framing may be constructed and the fireplace positioned into the opening.

Usually, no special floor support is needed for the fireplace, however, to be certain:

1. Estimate the total weight of the fireplace system and surround materials such as brick, stone, etc., to be installed.

2. Measure the square footage of the floor space to be occupied by the system, surrounds and hearth extensions.

3. Note the floor construction, i.e. 2 x 6's, 2 x 8's or 2 x 10's, single or double joists, type and thickness of floor boards.

4. Use this information and consult your local building code to determine if you need additional support.

If you plan to raise the fireplace and hearth extension, build the platform assembly then position fireplace and hearth extension on top. Secure the platform to the floor to prevent possible shifting.

### INSTALLING THE FIREPLACE

**Step 1. Construct the Appliance Framing -** Frame appliance enclosure as illustrated in *Figures 5 through 8 on page 5 and 6.*

*(Note: Appliance may be positioned first and then the framing constructed around it.)*

If the appliance is to be elevated above floor level, a solid continuous platform must be constructed.

**IMPORTANT: UNDER NO CIRCUMSTANCES CAN THE FIREPLACE TOP SPACERS (FIGURE 2) BE REMOVED OR MODIFIED, NOR MAY YOU NOTCH THE HEADER TO FIT AROUND OR BE INSTALLED LOWER THAN THE SPACERS. THE HEADER MAY BE IN DIRECT CONTACT WITH THE TOP SPACERS BUT MAY NOT BE SUPPORTED BY THEM.**

Consult all local codes.

**Step 2. Route Gas Supply Line -** Route gas line (*Figure 5*) using techniques and materials prescribed by local and/or national codes. It is recommended that a gas line of 1/2" or greater diameter be used to allow full gas volume to the fireplace. Undue pressure loss will occur if the pipe is too small.

The gas line should extend a total of 2 in. (51 mm) maximum into the appliance control compartment.

When rigid pipe is used, an ANSI approved manual shut-off valve and union must be installed upstream of the fireplace.

Ensure that a sediment trap is installed in the existing gas line, if not, install a sediment trap upstream to prevent moisture and contaminants from passing through trap to the appliance controls and burners. Failure to do so could prevent the appliance from operating reliably.

An external regulator must be used on all propane (L.P.G.) heaters to reduce the supply tank pressure to 13" w.c. (maximum). Any copper tubing used to supply propane (L.P.G.) from the tank must be internally tinned.

**IMPORTANT: HOLD GAS VALVE SECURELY TO PREVENT MOVEMENT WHEN CONNECTING TO INLET GAS LINE**

**WARNING: CONNECTING DIRECTLY TO AN UNREGULATED PROPANE (L.P.G.) TANK MAY CAUSE AN EXPLOSION.**

All appliances are equipped with a gas flex line and shutoff valve attached directly to the gas control valve. To quickly and easily complete the gas line routing, use the gas flex line kit.

**Step 3. Position the Appliance -** Slide the fireplace into prepared framing.

*(Note: Appliance may be positioned first and then the framing constructed around it.)*

Fireplace should be secured to side framing members using the full length 1/2 inch nailing flanges that are integral to the appliance at each side. Use 8d nails (*Figure 9*).

*Note: The nailing tabs and the area directly behind the nailing tabs are exempt from the clearances described on the fireplace clearance label.*

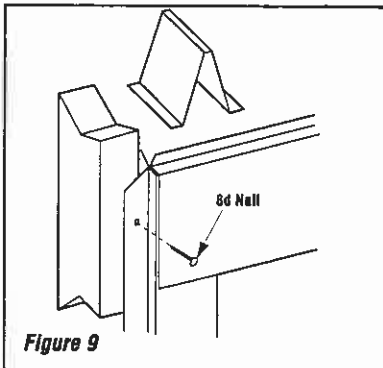

Fireplace may be anchored to floor. Bend down four (4) anchor tabs located at the base of the fireplace and secure to the floor by nailing with 8d nails (*Figure 10*).

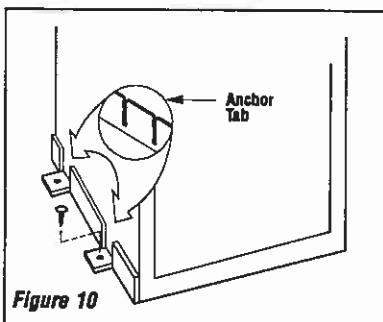

NOTE: DIAGRAMS & ILLUSTRATIONS NOT TO SCALE.

### Step 4. Install the Vent System & Exterior Termination -

**A -** Connect the factory-supplied B-Vent connector (found taped to the top of the unit) as shown in *Figure 11*. Press it into the lanced protrusions internal to the flue outlet collar as far as the horizontal rolled seam located on the lower part of the connector, and secure with four sheetmetal screws (# 8 or larger).

**B -** Slip an 8" (203 mm) B-Vent system over the B-Vent connector and secure with four sheetmetal screws (# 8 or larger), and install the remainder of the B-Vent to the outside. Minimum overall height of the vent system and appliance must be 10' (2.54 m) vertical (no offset) or 12' (3.7 m) when an offset up to 60 degrees from the vertical is used. (*Figure 12*).

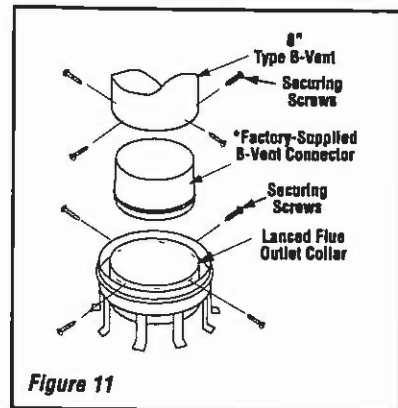

Install the B-vent system in accordance with the vent manufacturer's instructions.

**CAUTION: THIS APPLIANCE CANNOT BE VENTED HORIZONTALLY.**

*Note: Refer to the vent manufacturers installation instructions for variations of venting techniques. If common venting of several units is contemplated, it should be discussed with an architect and the local Building Department.*

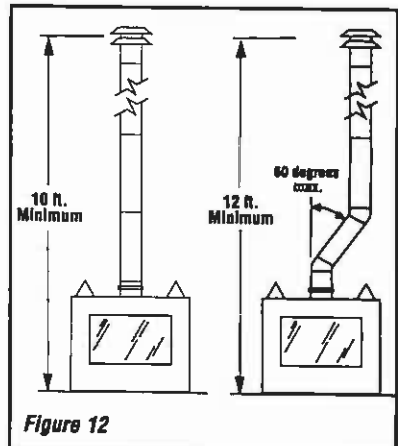

Figure 12

**Control Compartment Access - GRDE Units**  
Remove the front glass enclosure panel.

**Caution:** Glass and metal frames are hot during unit operation. Wait for panel to cool before attempting its removal.

To remove panel, grasp one of the handles and the upper left corner of the door, and carefully lift up and pull the bottom of the panel assembly away from the fireplace. Set aside for later reinstallation. See *Figure 13*.



Once the glass enclosure panel has been removed, pull the bottom control compartment panel away from the unit by inserting a finger into each of the two panel holes. See *Figure 14*.

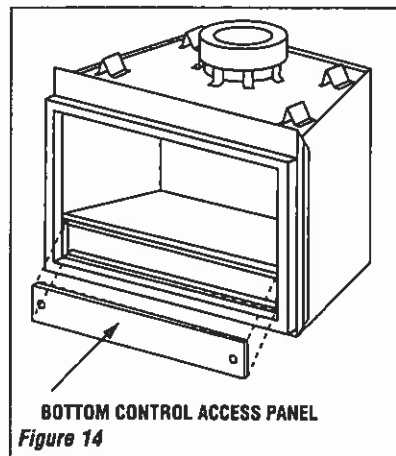

To reinstall the bottom control compartment panel, insert a finger into each of the two panel holes and gently press it into the control compartment frame. See *Figure 14*.

**Step 5. Field Wiring** – Refer to Section A for millivolt appliances and Section B for electronic appliances.

**A. Honeywell Millivolt Wiring**  
(See *Figure 15*) –

1. Select any of the following optional controls: wall-mounted On/Off switch or optional remote control kit.
2. Mount ON/OFF wall switch in a convenient location on a wall near the fireplace.
3. Wire the switch within the millivolt control circuit using the 18 feet of 2 conductor wire supplied with the unit. **Caution:** do not connect the optional wall switch to a 120V power supply.
4. Alternatively, the appliance may be operated without the use of the controls indicated in step 1, solely by manipulating the gas valve control knob. In order to use this method, twist the free ends of the two conductor wire (located on top of the unit) together as shown in *Figure 15*.

**Note:** The supplied 18 feet of 2 conductor wire has one end of each conductor connected to the gas valve circuit and the other end of each conductor placed loose on top of the unit.

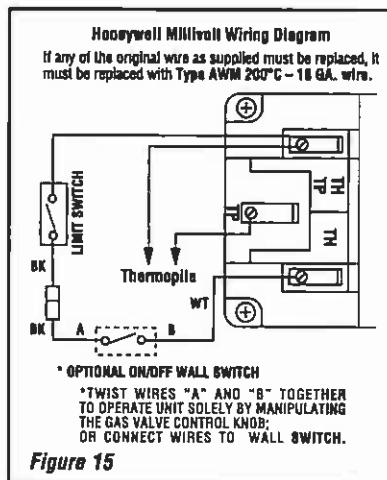

**B. Electronic Wiring**  
(See *other figures 18 on page 9*) –

**Note:** The electronic appliance must be connected to the main power supply.

1. Remove the junction box cover (*Figure 16*) by removing the hex head screw. The junction box cover has a 7/8 inch (22mm) knockout hole for a conduit busing. Route a 3-wire 120Vac 60Hz 1ph power supply to the appliance junction box (*Figure 18 on page 9*).

NOTE: DIAGRAMS & ILLUSTRATIONS NOT TO SCALE.

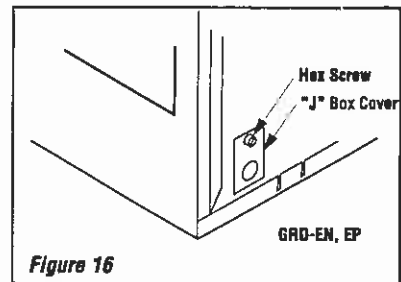

*Figure 16*

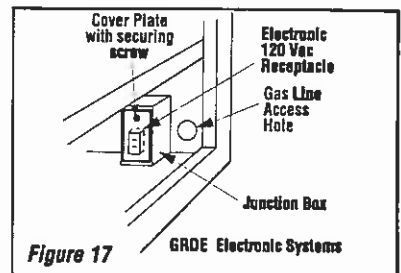

*Figure 17*

2. Remove the junction box cover plate from inside the unit by removing the plate's one securing screws. See *figure 17*.

**Note:** The gas valve-mounted ON/OFF switch is shown in *figure 18 on page 9*. It is integral with the gas valve and should be set to the ON position.

3. Connect the black and white electrical power supply wire to the receptacle's terminals, the ground wire to the receptacle's ground terminal. Make sure that the ground is also connected to the junction box ground screw.
4. Install wall-mounted ON/OFF control switch in a convenient location on a wall near the fireplace.  
An optional remote control kit (See Homeowner's Care and Operating Instructions Manual) may also be used to operate the appliance.
5. Wire the wall-mounted ON/OFF control switch in the the low voltage circuit using the 18 feet of 2 conductor wire supplied with the unit as shown in *Figure 18 On page 9*.

**Note:** The supplied 18 feet of 2 conductor wire has one end of each conductor connected to the gas valve circuit and the other end of each conductor placed loose on top of the unit.

6. After the wiring is complete, replace the inside and outside junction box cover plate.



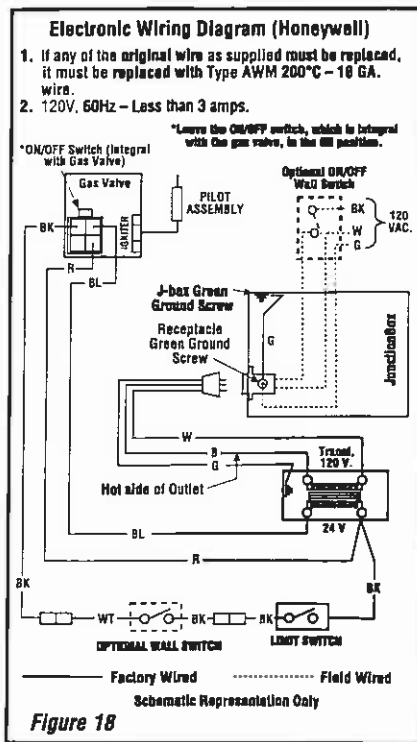

Figure 18

**IMPORTANT:** Ground lead must be connected to the green screw located on the outlet box. See Figure 18. Failure to do so will result in a potential safety hazard. The appliance must be electrically grounded in accordance with local codes or, in the absence of local codes, the National Electrical Code, ANSI/NFPA 70-(latest edition). (In Canada, the current CSA C22-1 Canadian Electrical Code.)

**Step 6. Connecting Gas Line -**

Make gas line connections. All codes require a shut-off valve mounted in the supply line. Figure 19 illustrates two methods for connecting the gas supply. The flex-line method utilizing the gas flex line provided with the appliance is acceptable in the U.S., however, Canadian requirements vary depending on locality. Installation must be in compliance with local codes. The millivolt and electronic control valve have 3/8" (10 mm) NPT thread inlet ports.

**WARNING: TO PREVENT DAMAGE TO THE VALVE AND OTHER ATTACHED COMPONENTS, HOLD VALVE FIRMLY IN PLACE WHILE TIGHTENING FITTINGS USED IN THE NEXT STEP.**

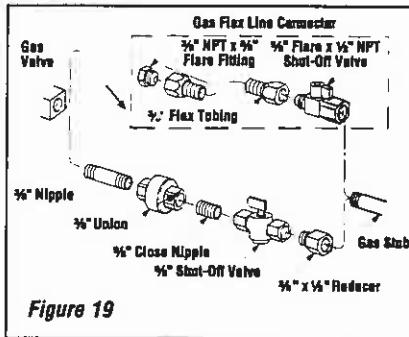

Figure 19

The gas control valve is located in the lower control compartment. See figure 20. To access the valve see page 9, the Control Compartment Access Section.

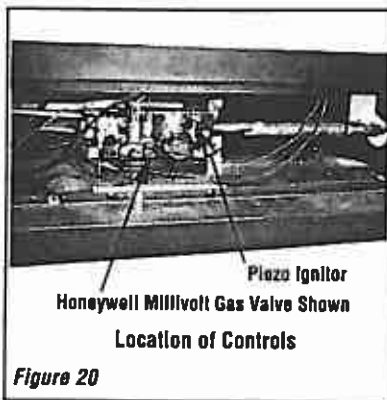

Figure 20

Secure all joints tightly using appropriate tools and sealing compounds (ensure propane resistant compounds are used in propane applications).

Turn on gas supply and test for gas leaks using a soapy water solution. **Never use an open flame to check for leaks.**

A. Mix a 50% dish soap, 50% water solution.

B. Light the appliance (refer to the lighting instructions provided in the Homeowner's Care and Operation Instructions).

C. Brush all joints and connections with the soapy water solution to check for leaks. If bubbles are formed, or gas odor is detected, turn the gas control knob to the "OFF" position. Either tighten or refasten the leaking connection and retest as described above.

D. When the gas lines are tested and leak free, observe the individual tongues of flame on the burner. Make sure all ports are open and producing flame evenly across the burner. If any ports are blocked, or partially blocked, clean out the ports.

NOTE: DIAGRAMS & ILLUSTRATIONS NOT TO SCALE.

**Step 7. Outside Air Kits -** Optional combustion (outside make-up air) kits, Model FOAK-4 or FAOK-4LD, may be used with these appliances. Refer to the installation instructions packaged with the air kits for specific installation information. If used, the outside air kit must be installed before the fireplace is framed and enclosed in the finished wall.

Outside air drawn into the fireplace supplies air to the fire for combustion. Only one combustion air duct on the left side of the fireplace is necessary if installed.

If additional length of duct is necessary, purchase locally available U.L. Class 0 or Class 1 metallic ducting. The duct may extend up to 50' (15.24 m) in any direction.

**Note:** When installing the air duct vertically, **DO NOT** terminate the duct closer than 3' below the chimney top.

The hand operated shut-off lever is located on the left side of the fireplace opening behind the screen. It should be connected to an extension bar as shown in Figure 21. To open the outside air damper, pull the extension bar all the way out. The outside air damper should be fully open when the fireplace is in use and completely closed when the fireplace is not being used. This will prevent outside cold air from entering the dwelling.

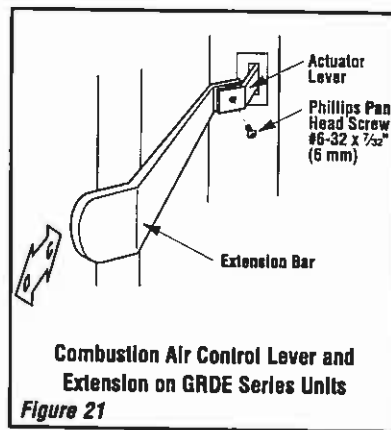

Figure 21

**CAUTION: NEVER LOCATE INLET WHERE IT CAN BE BLOCKED BY SHRUBS, SNOW DRIFTS, ETC. NEVER LOCATE INLET IN GARAGE OR ANY AREA WHERE THERE IS ANOTHER FUEL BURNING APPLIANCE OR PRODUCTS EMITTING COMBUSTIBLE GASES SUCH AS PAINT, GASOLINE, ETC. IN COLD CLIMATES, IT IS RECOMMENDED THE COMBUSTION AIR DUCT BE INSULATED.**

Outside combustion air ducting may be run upwards or vertically through framing and ceiling joists, with the hood installed through an outside wall and 3' (1 m) below the termination. Ducting may also be run downward through floor joists and under the home to a ventilated crawlspace not considered part of the living area of the home.

*Note: Do not terminate combustion air kit in attic space under any circumstances.*

After completing the installation of the optional combustion air vent system the actuator arm must be put in service and tested to ensure proper operation before completing any enclosure around the firebox. Failure to do so may result in extensive and costly rework.

Operate the actuator through several cycles including the closed position. Ensuring proper operation and freedom of movement. Return the actuator arm to the closed position.

**Step 8. Installing Logs, Rockwool; Vermiculite (propane units); Sand (natural gas units) –** The logs are packaged within the firebox with a bag of vermiculite (propane units) or sand (natural gas units). A bag of rockwool is located in the lower control compartment. Refer to the Homeowner's Care and Operation Instructions for detailed placement instructions.

### Step 9. Checking Appliance Operation

With gas line installed run initial system checkout before closing up the front of the unit. Follow the pilot lighting instructions provided in the Homeowner's Care and Operation Instructions. For piezo ignitor location see *Figure 20 on page 9*. *Note: Lighting Instructions are also found on the literature tag attached to the firebox support bracket located in the control compartment opening.*

When first lighting the appliance, it will take a few minutes for the line to purge itself of air. Once purging is complete, the pilot and burner will light and operate as indicated in the instruction manual. Subsequent lightings of the appliance will not require such purging. Inspect the pilot flame (remove logs, if necessary, handling carefully).

### Honeywell Millivolt Appliance Checkout

The gas control system on these appliances is a millivolt standing pilot type. It consists of a pilot burner, a piezo ignitor, a gas control valve, a burner assembly and an ON/OFF wall switch. A temperature limit switch is wired in series with the millivolt wall switch and gas control valve. If a higher than normal temperature is sensed due to a blocked vent or prolonged downdraft, the limit switch will open and cause the burner to shut off.

The pilot flame should be steady, not lifting or floating. Flame should be blue in color with traces of orange at the outer edge. The top  $\frac{3}{8}$ " (10 mm) at the pilot generator (thermopile) should be engulfed in the pilot flame. The flame should project 1" (25 mm) beyond the hood at all three ports (*Figure 22*).

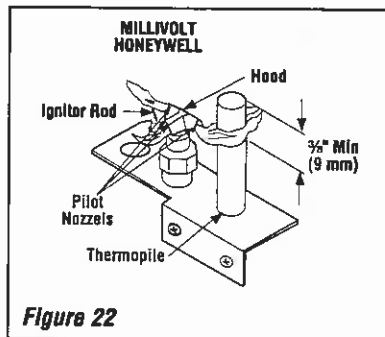

Replace logs if removed for pilot inspection. To light the burner; turn "ON" the remote wall switch and rotate the gas valve control knob counterclockwise to the "ON" position.

### Electronic Appliance Checkout

The gas control system on these appliances is an electronic low voltage gas control valve with an intermittent ignitor. It consists of a low voltage gas control valve, an intermittent ignition system, transformer and a burner assembly. A temperature limit switch is wired in series with the gas control valve. If a higher than normal temperature is sensed, due to a blocked vent or prolonged downdraft, the limit switch will open and cause the burner to shut off.

To light the burner, turn 'ON' the remote wall switch and turn the gas control switch to the "ON" position. Ensure the ignitor lights the pilot. The pilot flame should engulf the flame rod as shown in *Figure 23*.

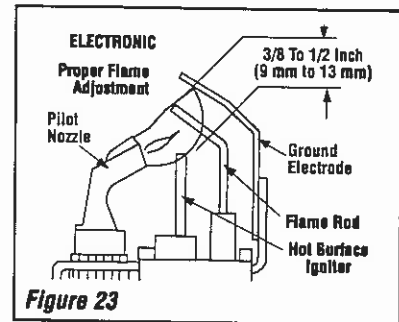

### Step 10. Install Front Glass Enclosure Panel -

To install panel, grasp one of the handles and the upper left corner of the door, and carefully fit the upper corner door pins into their mating holes in the upper frame of the unit front opening.

Swing the bottom of the panel assembly gently in towards the fireplace. Set the lower corner pins into their mating cabinet frame holes and carefully let the enclosure panel down to rest on the cabinet frame. See *figure 13 on page 8*.

**Warning: The appliance must have the front glass enclosure panel installed in its normal position during unit operation.**

## Step 11. Spillage Test and Safety Limit Switch Operation

### Spillage Test

After appliance installation, perform this spillage test to verify that proper venting conditions exist:

- 1 - Place unit in its normally-operated condition, that is, with the glass door in place.
- 2 - Close all doors and windows in the room. Turn on all exhaust fans in the house.
- 3 - Light the appliance.
- 4 - Wait 15 minutes.
- 5 - To check for venting action, start by holding a smoke producing device within an inch of one edge (side edge, not top or bottom edge) of the glass door. The smoke should be drawn toward the edge of the glass door. Continue the test by moving the smoke producing device along the entire length of both side-edges of the glass door.
- 6 - If the smoke is not drawn towards the edges of the glass door turn off the appliance and call a qualified service technician.

### Automatically-Reset Safety Limit Switch

This appliance is equipped with an automatically-reset blocked flue safety limit switch. Refer to *figure 24* for its location. If, during appliance operation, the flame goes out (independently of the burner on/off wall switch) in a regularly repeated pattern, it may be due to the operation of this safety limit switch. Call a qualified service technician immediately, to determine the cause of the cycling ON/OFF burner condition.

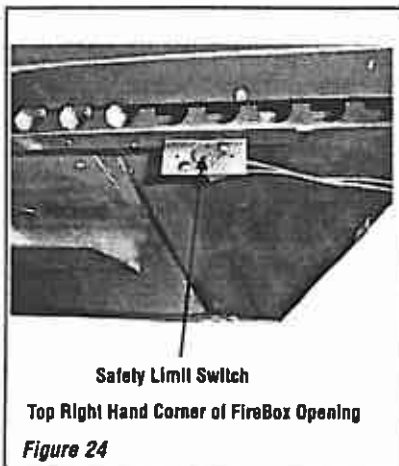

Figure 24

## FINISHING REQUIREMENTS Wall Details

Complete finished interior wall. To install the appliance facing flush with the finished wall, position framework to accommodate the thickness of the finished wall (*Figure 26*).

Surround materials (noncombustible) can be placed around the appliance facing to provide a flush surface between the surround materials and the appliance front facing. Do not cover the bottom control compartment access on the GRDE. Access to the control area must be maintained for service and operation of this appliance. (*Figures 27*).

**Note:** Combustible wall finish materials and/or surround materials must not be allowed to encroach the area defined by the appliance front face (black sheet metal). Never allow combustible materials to be positioned in front of or overlapping the appliance front face.

### Hearth Extensions

A hearth extension is not required with this appliance. Any hearth extension used is for appearance only and does not have to conform to standard hearth extension installation requirements.

### Mantels

See *Figures 25, 26 and 27* for combustible mantel shelf projections from the wall and for the mantel's minimum vertical distance from the top of the firebox opening. No other mantel length/height combinations are allowable.

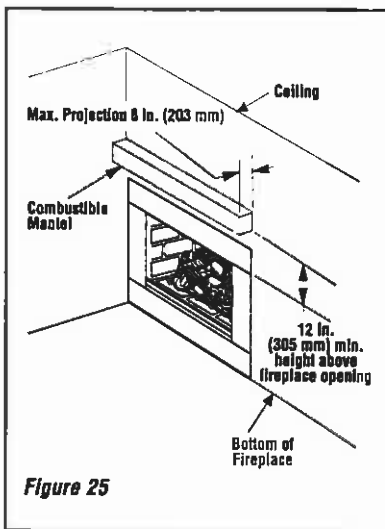

Figure 25

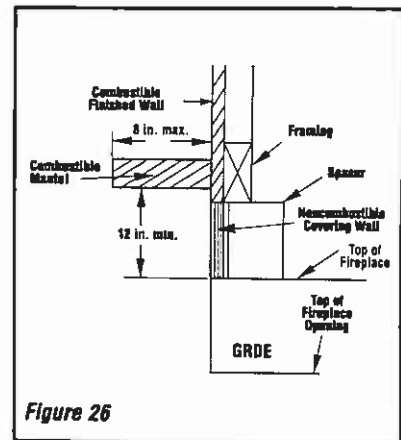

Figure 26

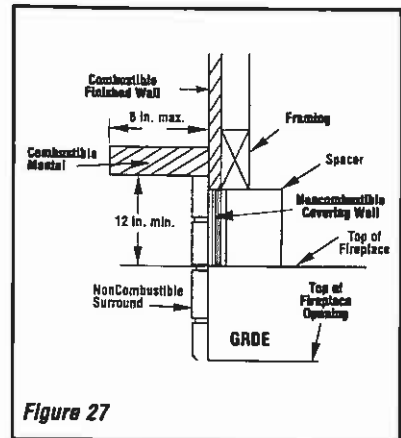

Figure 27

## COLD CLIMATE INSULATION

If you live in a cold climate, seal all cracks around your appliance with noncombustible material and wherever cold air could enter the room. It is especially important to insulate outside chase cavity between studs and under floor on which appliance rests, if floor is above ground level. Ensure that the clearance requirements for venting are always maintained.

To avoid air intrusion, surround material must be caulked where it meets the black metal facing of the appliance. Only use a noncombustible caulking material to seal this area.

Do not place insulation materials within the 1" gas vent system clearance space.

### INSTALLATION ACCESSORIES

The following accessory items are available for use in the installation of this appliance.

#### Outside Air Kits Models FOAK-4 and FOAK-4LD

Outside Air kits are available with duct (FOAK-4) and without duct (FOAK-4LD) for use if outside combustion air is required or desired. If model FOAK-4LD is used it must be used in conjunction with locally purchased, non-combustible Class 1 or Class 0 flexible duct.

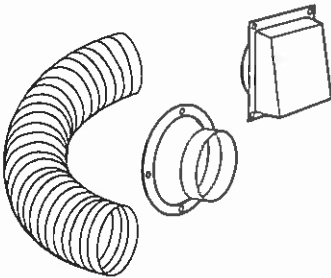

Outside Combustion Air Kits		
(with duct)	81L87	FOAK-4
(without duct)	81L88	FOAK-4LD

### Wall Switch Kit FWSK

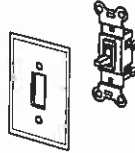

Wall Switch Kit

85L87

FWSK

## GAS CONVERSION KITS

**WARNING: THIS CONVERSION KIT SHALL BE INSTALLED BY A QUALIFIED SERVICE AGENCY IN ACCORDANCE WITH THE MANUFACTURER'S INSTRUCTIONS AND ALL APPLICABLE CODES AND REQUIREMENTS OF THE AUTHORIZED HAVING JURISDICTION. IF THE INFORMATION IN THESE INSTRUCTIONS IS NOT FOLLOWED EXACTLY, A FIRE, EXPLOSION OR PRODUCTION OF CARBON MONOXIDE MAY RESULT CAUSING PROPERTY DAMAGE, PERSONAL INJURY OR LOSS OF LIFE. THE INSTALLATION IS NOT PROPER AND COMPLETE UNTIL THE OPERATION OF THE CONVERTED APPLIANCE IS CHECKED AS SPECIFIED IN THE OWNER INSTRUCTIONS SUPPLIED WITH THE KIT. THE QUALIFIED SERVICE AGENCY PERFORMING THIS INSTALLATION ASSUMES RESPONSIBILITY FOR THIS CONVERSION.**

**AVERTISSEMENT: CET ÉQUIPEMENT DE CONVERSION SERA INSTALLÉ PAR UNE AGENCE QUALIFIÉE DE SERVICE CONFORMÉMENT AUX INSTRUCTIONS DU FABRICANT ET TOUTES EXIGENCES ET CODES APPLICABLES DE L'AUTORISÉS AVOIR LA JURIDICTION. SI L'INFORMATION DANS CETTE INSTRUCTION N'EST PAS SUIVIE EXACTEMENT, UN FEU, EXPLOSION OU PRODUCTION DE PROTOXYDE DE CARBONE PEUT RÉSULTER LE DOMMAGES CAUSER DE PROPRIÉTÉ, PERTE OU BLESSURE PERSONNELLE DE VIE. L'AGENCE QUALIFIÉE DE SERVICE EST ESPONSABLE DE L'INSTALLATION PROPRE DE CET ÉQUIPEMENT. L'INSTALLATION N'EST PAS PROPRE ET COMPLÈTE JUSQU'À L'OPÉRATION DE L'APPAREIL CONVERTI EST CHÉQUE SUIVANT LES CRITÈRES ÉTABLIS DANS LES INSTRUCTIONS DE PROPRIÉTAIRE PROVISIONNÉES AVEC L'ÉQUIPEMENT.**

### In Canada:

THE CONVERSION SHALL BE CARRIED OUT IN ACCORDANCE WITH THE REQUIREMENTS OF THE PROVINCIAL AUTHORITIES HAVING JURISDICTION AND IN ACCORDANCE WITH THE REQUIREMENTS OF THE CAN1-B149.1 AND .2 INSTALLATION CODE.

LA CONVERSION DEVRA ÊTRE EFFECTUÉE CONFORMÉMENT AUX RECOMMANDATIONS DES AUTORITÉS PROVINCIALES AYANT JURISDICTION ET CONFORMÉMENT AUX EXIGENCES DU CODE D'INSTALLATION CAN1-B149.1 ET.2.

Gas conversion kits are available to adapt your appliance from the use of one type of gas to the use of another. These kits contain all the necessary components needed to complete the task including labeling that must be affixed to ensure safe operation.

Kit part numbers are listed here and the following steps detail the conversion procedure.

**Step 1.** Turn off the gas supply to the appliance. Remove the front glass enclosure panel from the appliance. Access the control compartment.

**Step 2.** Carefully remove the logs. Exercise care so as not to break the logs.

**Step 3.** Remove the grate. From inside the control compartment, undo the valve tube assembly from the union elbow, remove the orifice from the vertical section of the burner tube. See *Figure 28*.

Millivolt Honeywell Systems - Natural To Propane Gas Conversion Kits		
	Unit Type	Catalog No.
GRDE- 8038/8043	millivolt	12M93
	electronic	12M95

Millivolt Honeywell Systems - Propane To Natural Gas Conversion Kits		
	Unit Type	Catalog No.
GRDE- 8038/8043	millivolt	12M94
	electronic	12M96

From inside the firebox, remove the fasteners that secure the L-shaped bracket to the back of the pan burner; remove the fasteners that secure the pilot assembly to the back of the burner, and then remove the burner with the rockwool, and sand or vermiculite.

#### Step 4. Honeywell Millivolt Systems -

a. Convert the gas valve as follows (see *Figure 29* and the instructions provided with the kit):  
Remove the black thread-protecting cap. Remove the conversion flip cap by turning it counterclockwise. Invert the flip cap so that the letters associated with the desired gas type are positioned closest to the valve body. NG is for natural gas and LP is for propane. Tighten the flip cap by turning it clockwise. Replace the black thread-protecting cap.

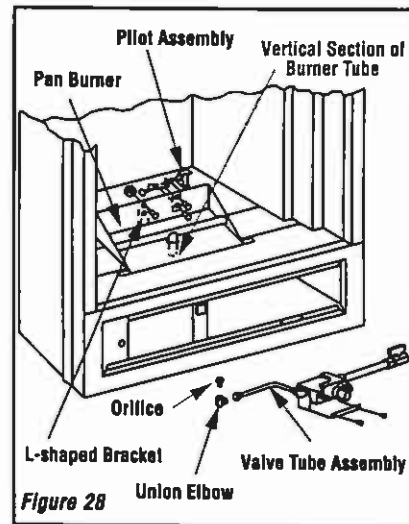

Figure 28

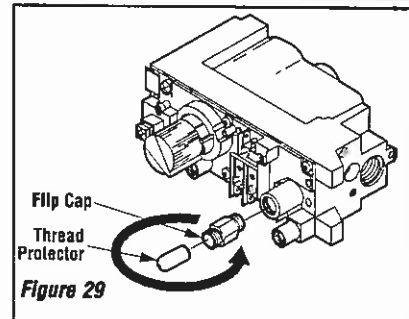

Figure 29

b. Attach manometer to the manifold side pressure test fitting and verify manifold pressure reads 3.5 inches water column (6.54 MmHg) for natural gas, and 10.0 inches water column (18.69 MmHg) for propane gas.

NOTE: DIAGRAMS & ILLUSTRATIONS NOT TO SCALE.

c. Convert the pilot orifice as follows (see Figures 30, 31 and 32):

**Note - Use extra care not to engage the orifice strip with the 7/16" open end wrench (contacting the orifice strip could cause strip distortion rendering the pilot inoperative). Also avoid wrench contact to any of the other pilot parts.**

Use a 7/16" open end wrench and turn the pilot hex fitting counter-clockwise 1/4 turn. (See Figure 30).

**Note - The orifice strip tab may be randomly located on any side of the hex fitting.**

d. Push the orifice strip tab all the way against the hex fitting to align the appropriate gas type orifice (see Figures 31 and 32). The type of gas for which the pilot is set, is, the gas type shown on the tab.

e. Retighten, clockwise, the pilot hex fitting until the pilot hood aligns with the thermocouple and thermopile as indicated by the arrows shown in Figure 30.

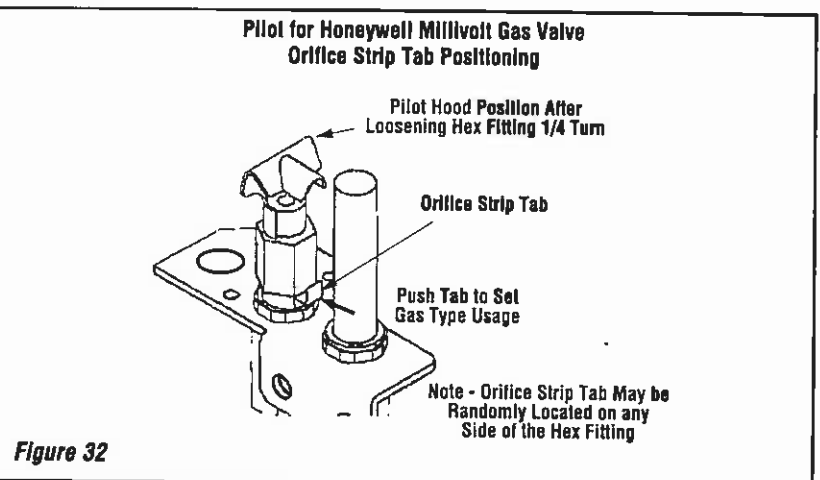
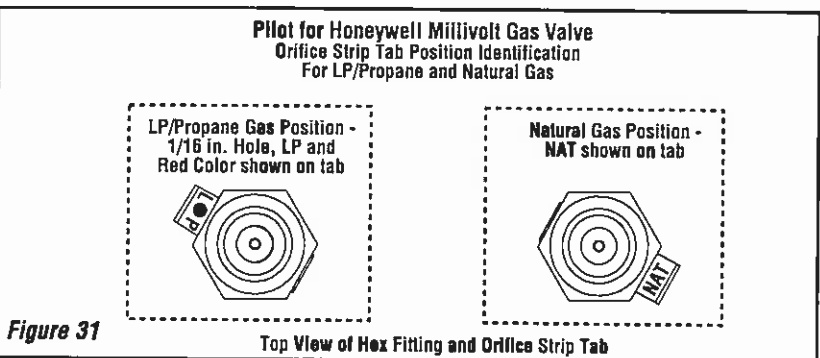
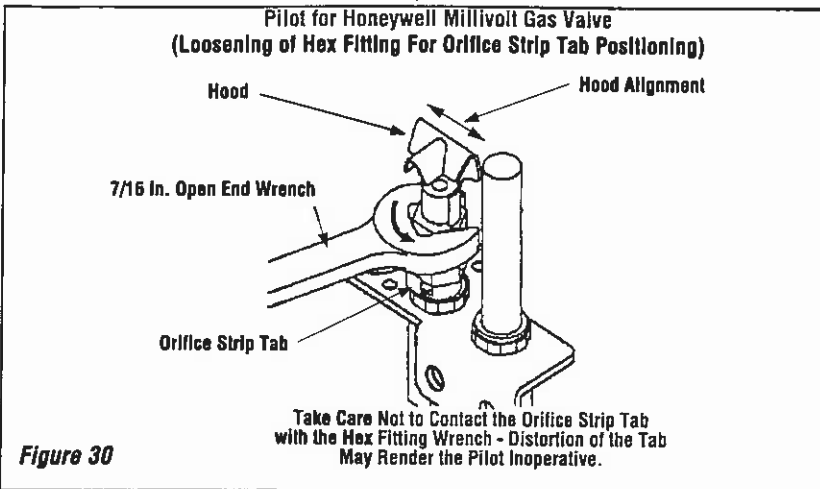

### Electronic Appliances

**Step 5. Honeywell Electronic Valves -** See Figure 34 on page 15 and the instructions provided with the kit. Remove the slotted cap screw, o-ring, pressure-regulating adjusting screw and spring. Retain all parts for possible later use. Install new components from the kit. Black cap and red spring for propane gas units. Silver cap and stainless steel spring for natural gas units. Before installing the cap, attach manometer to the manifold side pressure test fitting and adjust screw until pressure reads 3.5 inches water column (0.87 kPa) for natural gas, and 10.0 inches water column (2.49 kPa) for propane gas.

See Figure 33 on page 15 and replace the pilot orifice as follows: Remove the ignitor assembly retainer clip, and carefully remove the ignitor assembly.

**Exercise extreme care to prevent damage to or breakage of the Ignitor assembly.** Remove the screw securing the pilot assembly to its mounting bracket. Back off the flare nut at the end of the pilot gas line to free the pilot assembly from the gas line. Remove the pilot orifice and replace it with the one provided with the conversion kit. Reinstall the pilot assembly by reversing the steps detailed here.

**When reinstalling the ignitor assembly, use extreme care to prevent damage and breakage. Do not apply any leverage to the ignitor assembly while restoring the retainer clip to its original position.**

### All Models

**Step 6.** Replace the orifice previously removed from the burner manifold and replace it with the one provided with the kit, (#46) for natural gas units and (#30) for propane (Figure 35 on page 15).

**Step 7.** Replace the previously removed burner with the one supplied in the conversion kit. Also replace the vermiculite with sand or the sand with vermiculite.

**Note: The natural gas units use a different burner than the propane units. Natural gas burner part no. is 045241; Propane gas burner part no. is 045243.**

**Propane units use vermiculite; Natural gas use sand. Don't use sand with propane units.**

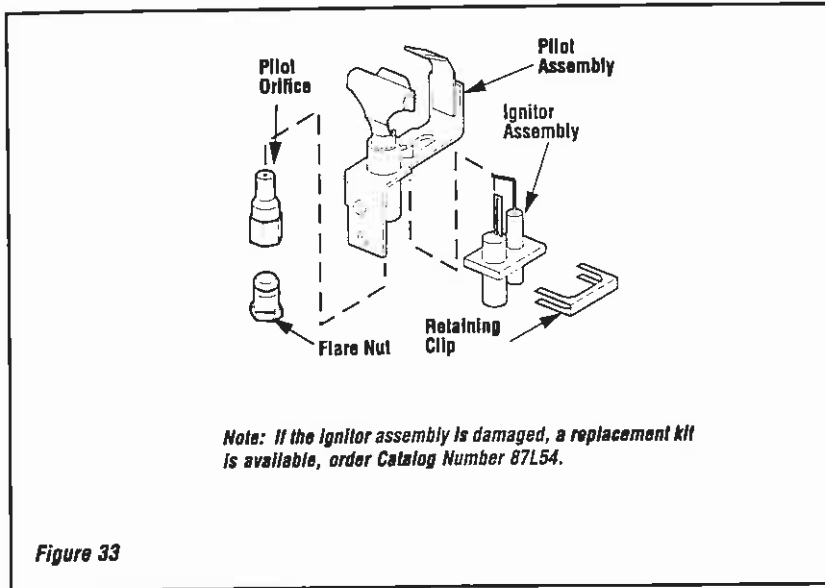

Figure 33

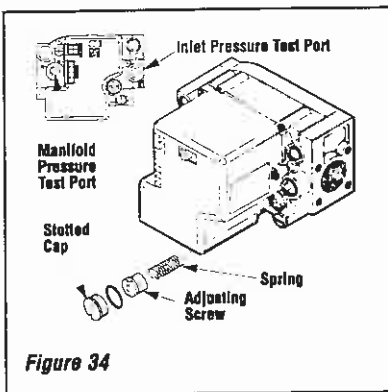

Figure 34

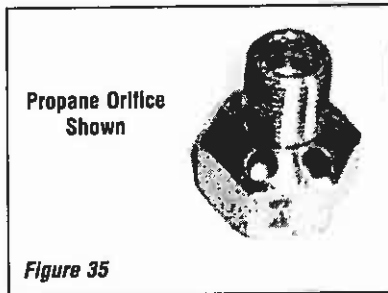

Figure 35

**Step 8.** Reassemble all removed components by reversing the procedures outlined in the preceding steps. Use pipe joint compound or Teflon tape on all pipe fittings before installing (ensure propane resistant compounds are used in propane applications, do not use pipe joint compounds on flare fittings).

**Step 9.** Attach appropriate conversion kit label (Figure 36) to the rating plate on the appliance.

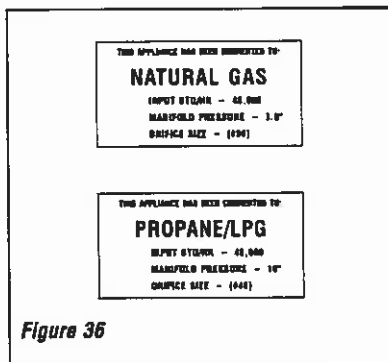

Figure 36

**Step 10.** Turn on gas supply and test for gas leaks. See step 6 on page 9.

NOTE: DIAGRAMS & ILLUSTRATIONS NOT TO SCALE.

LENNOX reserves the right to make changes at any time, without notice, in design, materials, specifications, prices and also to discontinue colors, styles and products. Consult your local distributor for fireplace code information.

**LENNOX<sup>®</sup>**

**HEARTH PRODUCTS**

Printed in U.S.A. © 2001 by LENNOX  
P/N 850,009M REV. A 11/2001

1110 West Taft Avenue • Orange, CA 92865