

# INSTALLATION AND OPERATION INSTRUCTIONS

for the **MAJESTIC**<sup>®</sup>  
SH42  
Factory Built Fireplace

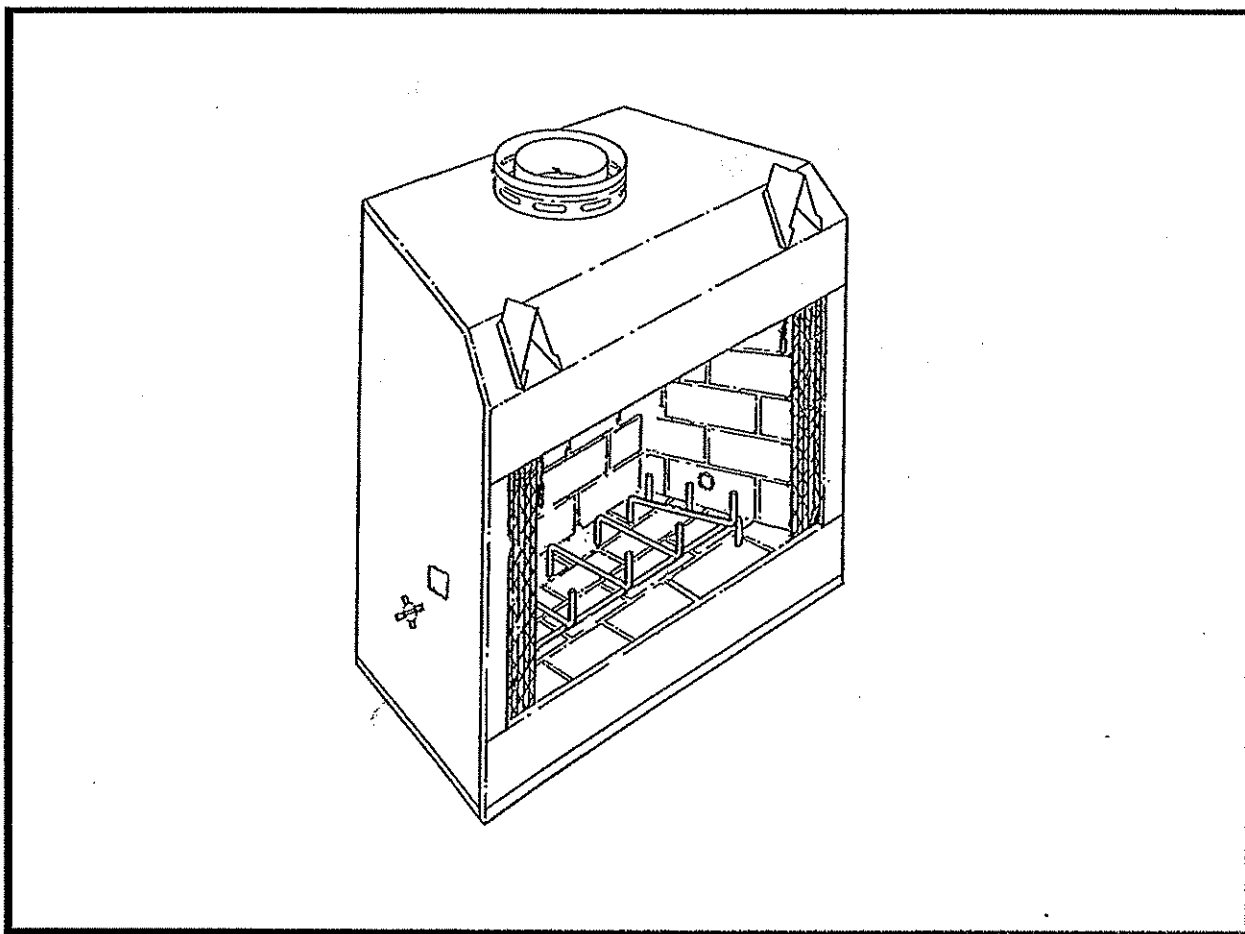

**IMPORTANT:** Read all instructions carefully before starting installation. Failure to follow this installation instruction may result in a possible fire hazard and will void the Majestic warranty.

Save this manual for future reference.

**MAJESTIC**<sup>®</sup>

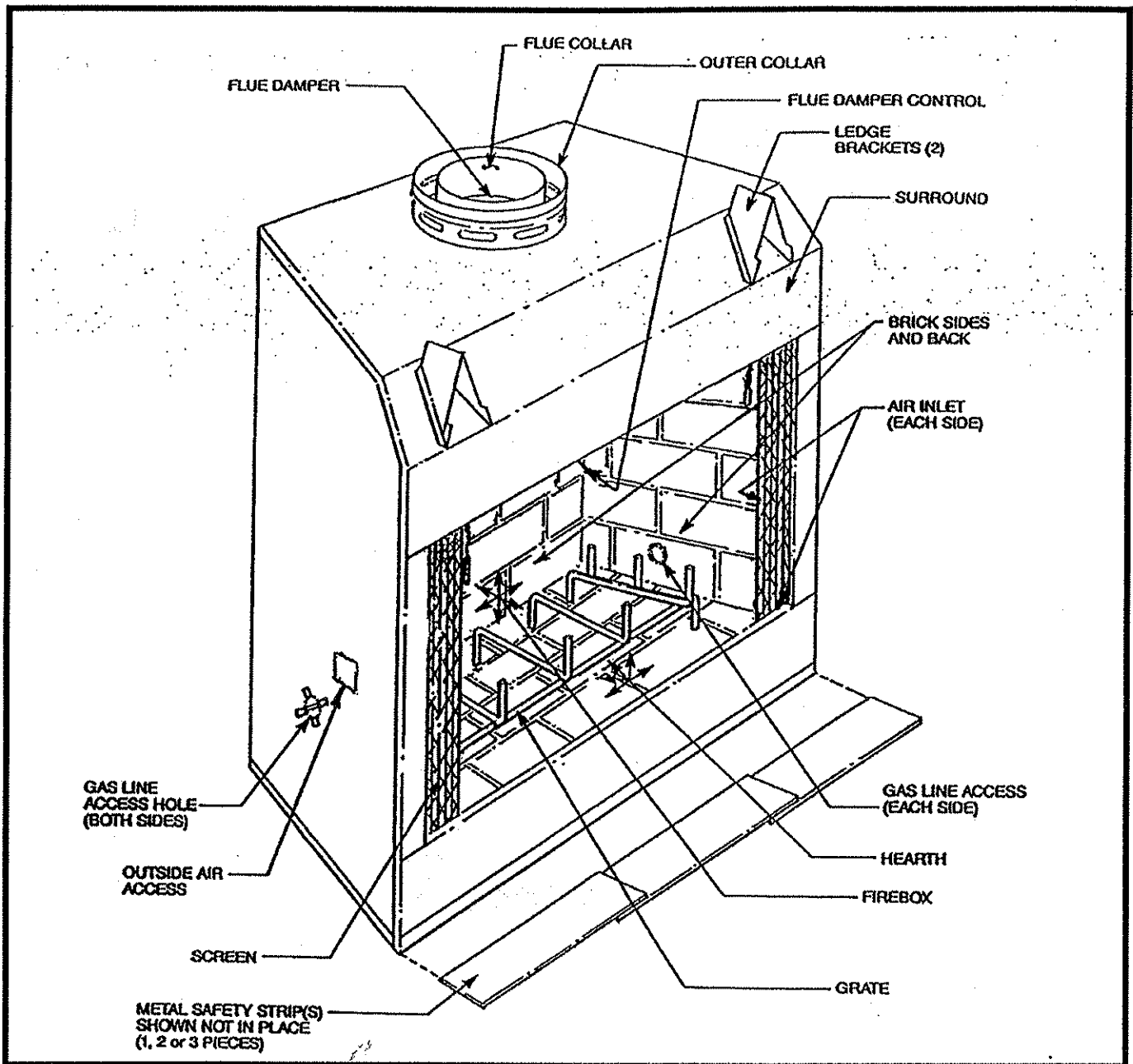

Fig. 1. Parts of the Majestic SH42 Fireplace.

### Table of Contents

	Page
Identification of Parts	2
Installation Precautions	3
Installation Instructions	3
Reference Data	13
Accessory Parts	15

## INSTALLATION PRECAUTIONS

This Majestic Fireplace and its components have been tested and will operate safely when installed in accordance with this Installation Manual. Read all instructions **before** starting installation, then follow these instructions carefully **during** installation to maximize fireplace benefit and safety.

Report to your dealer any parts damaged in shipment. Specifically, check for loose insulation in the fireplace and damper operation.

This fireplace and chimney assembly is a highly engineered system, **unless you use Majestic or Equus Building Products components** which have been designed for the system, you may create a possible fire hazard.

**The Majestic warranty will be voided by, and Majestic disclaims any responsibility for, the following actions:**

Installation of any damaged fireplace or chimney component;

Modification of the fireplace, chimney assembly or any of the component parts thereof; (except for chase flashings as detailed in EQUUS Chimney Top Installation Instructions.)

Installation other than as instructed by Majestic; or

Installation and/or use of any component part or accessory not manufactured or approved by Majestic in combination or assembly with a Majestic fireplace system, notwithstanding any independent testing laboratory or other third party approval of such component part or accessory.

Any such action may create a possible fire hazard.

Consult your local building codes.

This fireplace and chimney system must be vented out-of-doors.

Do not obstruct or modify air inlet/outlet grilles in any manner.

**Do not install combustible materials on to the black fireplace surround.**

**Burn solid wood fuel only.**

**Do not install a fireplace insert or other products not specified for use with this fireplace.**

**The SH Series Fireplaces are not approved for installation in mobile homes.**

Prior to first firing, read Owner's Manual for operating instructions.

## INSTALLATION INSTRUCTIONS

### A. Installing the Fireplace

#### A-1. CHECK HOW ACCESSORIES ARE INSTALLED.

Determine where selected accessories fit into this fireplace installation procedure by checking the installation instructions provided with each accessory.

See *Accessory Parts*, page 15.

#### A-2. DETERMINE FIREPLACE LOCATION.

The fireplace can be mounted on any of the following surfaces:

- 1) A flat hard combustible surface.
- 2) A raised platform of combustible or non-combustible material.
- 3) On four (4) corners of the fireplace so contact is made on all four (4) beads and perimeter edges on the bottom of the unit.  
(Example: Four (4) concrete masonry blocks.)

A 3/4 inch air space to combustible materials or insulation must be maintained at back and sides of fireplace.

Nearby combustible floors and walls must be protected as detailed in Section G.

Refer to *Air Space Data and Dimensions* on pages 13 and 14 to be sure that the location which you have selected for your fireplace provides for clearance and framing restrictions.

At this point you should have decided what components to include in your installation, where the fireplace is to be located, and how the chimney will be routed to the roof (straight-up, offset or chase\*). If this has not been done, stop and consult your Majestic Dealer for assistance with this planning.

\*A chase is a vertical box-like structure which encloses the fireplace and/or its chimney, typically built on the

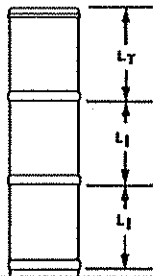

11CF CHIMNEY MODEL NO.	DIMENSIONS IN INCHES	
	DOUBLE WALL TOTAL LENGTH (LT)	INSTALLED LENGTH (LI)
11CF1	11½	10½
11CF18	17½	16½
11CF3	35½	34½
11CF4	47½	46½

Fig. 2. Installed lengths of chimney sections.

outside of the house with the fireplace opening cut in the outer wall of the home.

Note that the installed length of any chimney section is less than its total length (except for last section installed), because of its overlap at joints. (See Fig. 2.)

#### A-3. INSTALL METAL SAFETY STRIPS UNDER FIREPLACE.

See Step F, *Insulating Fireplace Enclosure for Cold Climates* before completing Step A-3.

Thoroughly clean intended fireplace location area. Move fireplace to the location where it is going to be installed. Lift fireplace front slightly to slide metal safety strip(s) under front bottom edge about 1 1/2 inches, allowing the remainder to extend out in front of the fireplace. Overlap the strips at least 1/2 inch to provide a positive joint. (See Fig. 3.) (Flat safety strips are packed with fireplace.)

In the event the fireplace is elevated above the floor, a "Z" shaped metal safety strip should be fabricated and used to protect combustible surfaces in front of the fireplace. This "Z" shaped safety strip is not provided, but must be fabricated of metal with each horizontal leg at least 1 1/2" wide - equal in length to the metal strips provided with each fireplace.

When positioning the fireplace on all mounting surfaces (see Step A-2), the metal safety strips must be installed as described above to provide protection to combustible (burnable) surfaces in front of the fireplace.

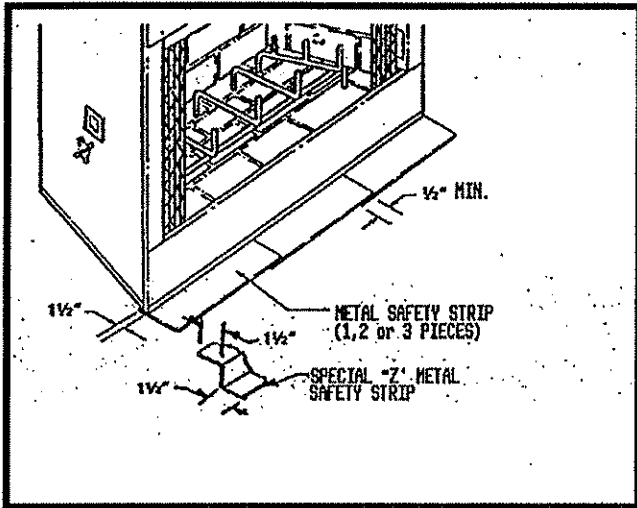

Fig. 3. Install metal strip(s) under front of fireplace.

**NOTE:** Safety strip is not required over non-combustible floors where all supports at the base of the fireplace are non-combustible.

**A-4. ANCHOR FIREPLACE IN POSITION.**

To prevent shifting of the fireplace and to maintain sealing (described later), anchor the fireplace. Two methods are possible on the SH42 Series. One method is to use the side fastening tabs provided on the fireplace basepan. (See Fig. 4.) The fireplace can then be secured to the floor. Refer to Framing and Finishing Section G. The second method uses the ledge brackets at the front of the fireplace. A nail may be installed through the ledge brackets and into the header to stabilize the top of the fireplace. (Refer to Fig. 4.)

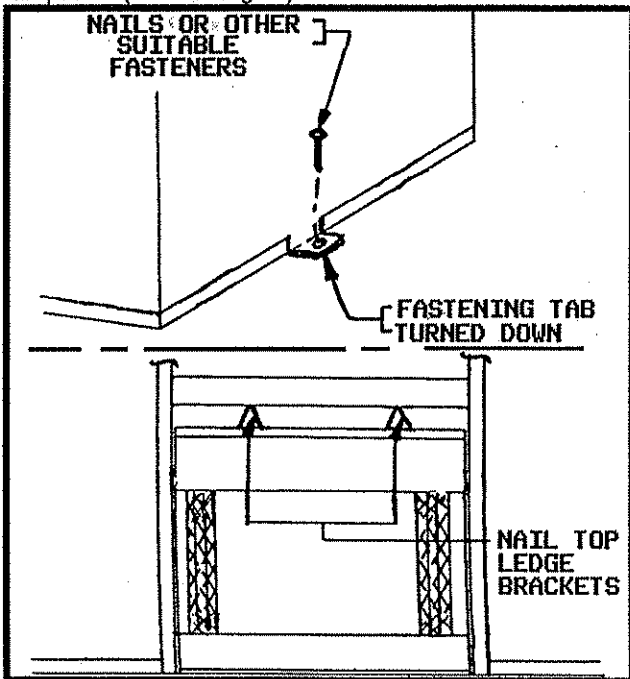

Fig. 4. Fasten fireplace in position using the fastening tabs or top standoff.

**B. Installing the Chimney**

**CAUTION:** REPORT TO YOUR DEALER ANY PARTS DAMAGED IN SHIPMENT, SPECIFICALLY, CHECK THE END CONNECTIONS OF CHIMNEY SECTIONS AND ELBOWS.

**NOTE:** The SH42 Series fireplace must use EQUUS Model 11CF, 11 inch, 2 wall chimney components. The installation procedure described in Section B (Installing the Chimney), applies to this system, chimney components may not be mixed. For clarification, refer to Accessory Section of this manual beginning on page 15. Components from Section 1 are common to all installations.

**B-1. LOCATE CENTERPOINT OF CHIMNEY - STRAIGHT UP INSTALLATION.**

If the fireplace is positioned against the wall behind it, measure out 10 7/16 inches from that wall and make a mark on the ceiling above the fireplace. Draw a line through this mark parallel to the back wall, defining the centerline of the chimney. (See Fig. 5.) Then, using a plumb bob positioned directly over the centerpoint of the fireplace flue collar, mark the ceiling to establish the chimney centerpoint. (See Fig. 5.)

**B-2. LOCATE CENTERPOINT OF CHIMNEY - OFFSET INSTALLATION.**

In order to clear an obstruction, it may be necessary to offset the chimney from the vertical plane. This is done by using EQUUS Chimney Elbows: Model 11CF30 (30°). Each offset requires a pair of elbows.

Use Table 1 and Fig. 6 to determine the offset that may be obtained using the various elbows.

Table 1. Offset dimensions.

	DIMENSIONS	
	T	S
	11CF30	11CF30
No Intermediate Section	0'3"	0'11"
One 1' Section	0'8 1/4"	1'8"
One 1 1/2' Section	0'11 1/4"	2'1 1/4"
Two 1' Sections	1'1 1/2"	2'5 1/4"
One 1' and One 1 1/2' Section	1'4 1/2"	2'10 1/4"
One 3' Section	1'8 1/4"	3'4 3/4"
Two 1' and One 1 1/2' Sections	1'9 3/4"	3'7 1/2"
One 4' Section	2'2 1/4"	4'3 1/4"
One 3' and One 1 1/2' Section	2'4 1/4"	4'7 1/4"
One 4' and One 1' Section	2'7 1/2"	5'0 1/4"
One 1', One 3' and One 1 1/2' Section	2'10 1/2"	5'5 1/2"
Two 3' Sections	3'1 1/2"	5'10 3/4"

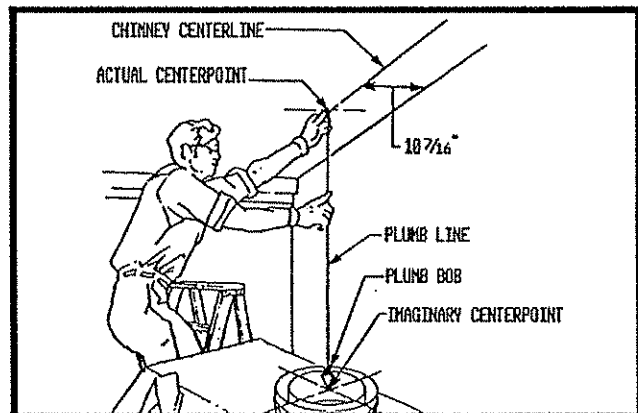

Fig. 5. Locate centerpoint of chimney with plumb line.

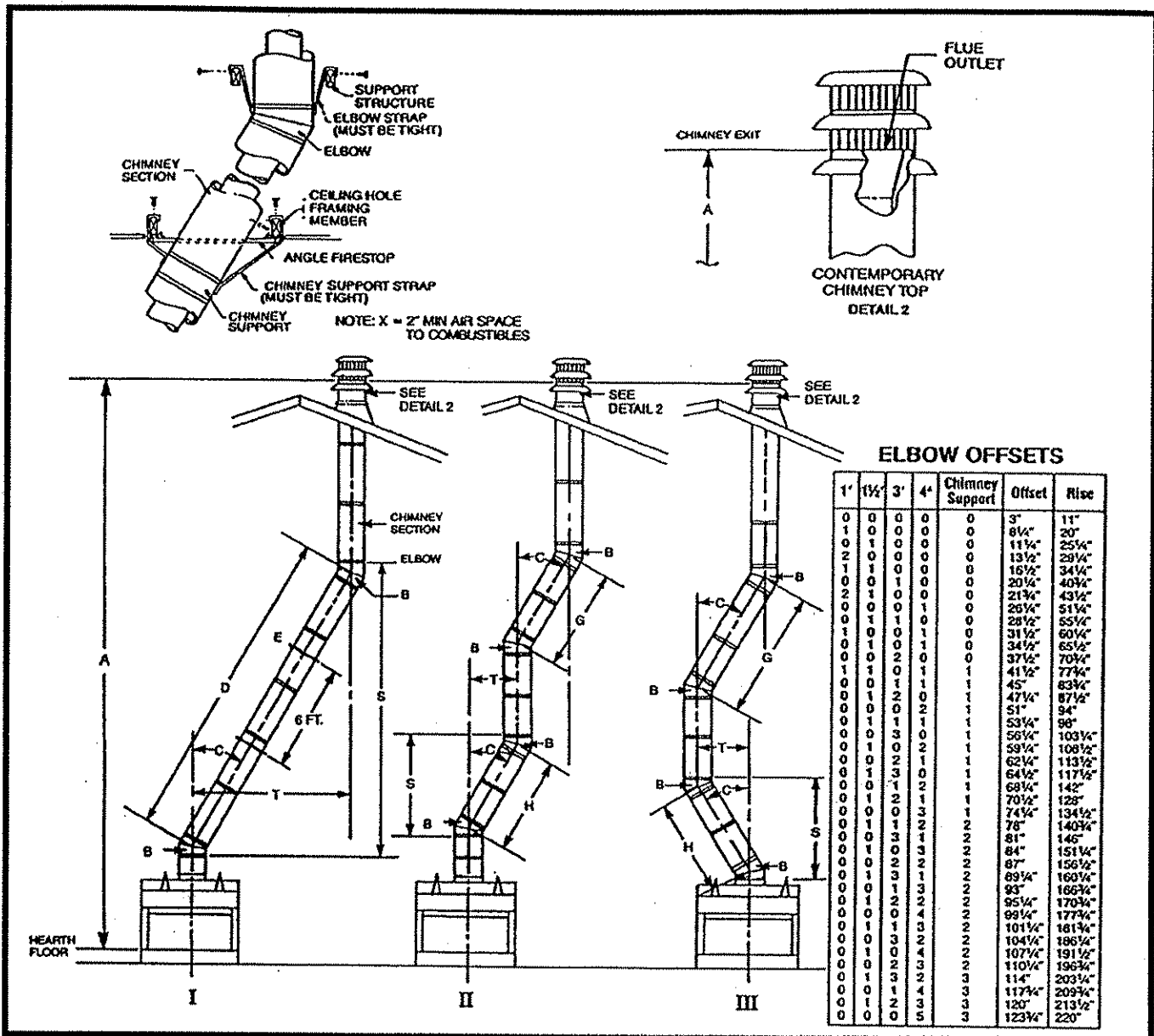

Fig. 6. Typical offset installations.

The following **safety rules** apply to offset installations. (The letters below match the letters in Fig. 6.)

A. Height of the chimney measured from the hearth to the chimney exit at top:

<b>SH42 Series</b>	
<b>Maximum:</b>	<b>90 Feet</b>
<b>Minimum:</b>	
Without Elbows	14 Ft. 0 In.
With 2 Elbows	15 Ft. 6 In.
With 4 Elbows	21 Ft. 0 In.

B. Do not use more than four (4) elbows per chimney. Attach the straps of the top elbows to a structural framing member. The first elbow of any pair does not have straps.

C. The chimney cannot be more than 30° from the vertical plane.

D. The maximum length of the angled run of the total chimney system is 20 feet. (G plus H cannot exceed 20 feet.)

E. A chimney support (Model 11CS) is required every 6 feet of angled run of chimney. Chimney supports are required at 30 feet and 60 feet of chimney height above the hearth also.

Determine the offset distance of your chimney arrangement from the centerline of the fireplace to the centerline of the chimney where it is to pass through the first ceiling. NOTE: This offset distance may not be your full offset distance (T). (See above.)

Locate on the ceiling the centerpoint of the chimney, as though a straight up chimney arrangement is to be used, by following the procedure outlined in Step B-1. Then measure your offset dimension from the actual chimney centerpoint on the ceiling. (See Fig. 7.)

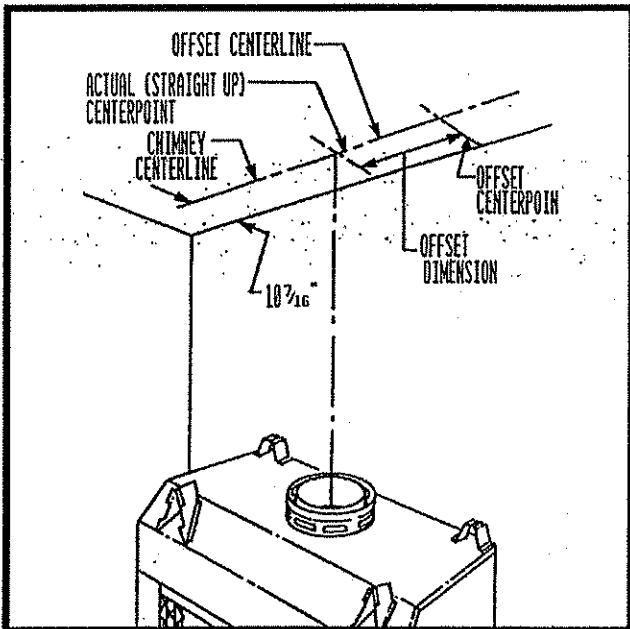

Fig. 7. Measure ceiling offset distance from actual straight up centerpoint.

**B-3. MARK AREA OF CEILING CHIMNEY HOLE.**

The size of the ceiling chimney hole will vary with the angle at which the chimney passes through the ceiling. Refer to Table 2.

Drive a nail up through the ceiling at the marked chimney centerpoint. Go to the floor above and check where the hole will be cut, relative to the ceiling joists and any obstructions such as wiring or plumbing runs. If necessary, re-position the chimney and/or the fireplace to better accommodate these joists and/or obstructions.

**B-4. CUT CEILING CHIMNEY HOLES.**

After covering the opening of the fireplace collar, cut the chimney hole through the ceiling. Recheck the hole to be sure that it measures the hole size selected from Table 2.

**B-5. FRAME CEILING CHIMNEY HOLE.**

Frame the ceiling chimney hole as shown in Fig. 8. It is good practice to use framing lumber that is the same size as the ceiling joists. (This is a requirement at the attic level.)

The inside dimension of the frame must be the same as the hole size selected from Table 2 in order to provide the required 2 inch air space between the outside diameter of the chimney and the edges of the framed ceiling hole.

Table 2. Sizes of ceiling chimney hole for installing firestop spacer.

Size of Chimney	Angle of chimney at ceiling	
	Vertical	30°
11" Flue	17 1/2 x 17 1/2	17 7/8 x 29 5/8

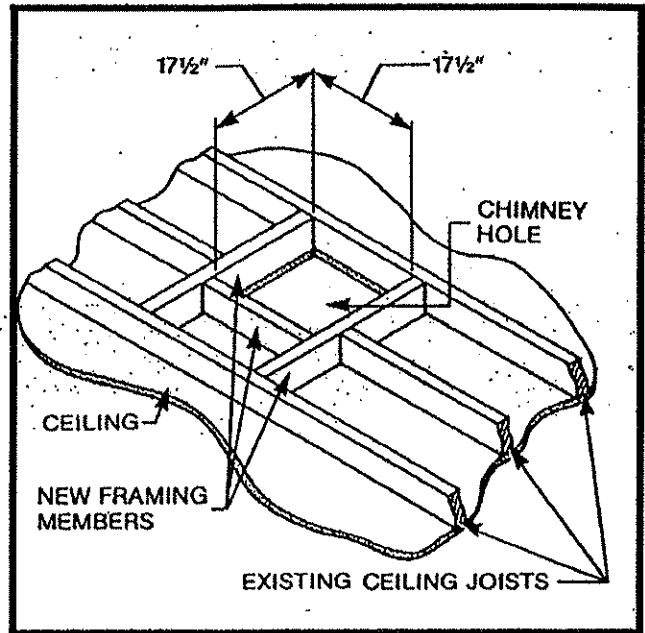

Fig. 8. Typical frame for ceiling chimney hole.

**B-6. INSTALL FIRESTOP SPACER.**

Firestop spacers are required for safety. The hole sizes listed in Table 2 for angled firestop spacers provide the minimum required air space to the chimney pipe for ceiling thicknesses up to 8 inches. When the combined thickness of the ceiling material, ceiling joists and flooring material exceed 8 inches, adjustments must be made in the framing to assure that the minimum air spaces to the chimney are maintained.

If the area above the ceiling is not an attic, position the firestop spacer with the flange on the ceiling side and the dished or angled portion extending up into the hole. If the area above the ceiling is an attic, position the firestop spacer with the flange on the top of the framed hole and the dished or angled portion extending down into the hole. (See Figs. 9 & 10.)

Table 3. Firestop model numbers.

TYPE FLUE	TYPE OF SPACER	MODEL NO.
11" straight	Dished	FS2A
11" 30° inclined	Angled	FS6A

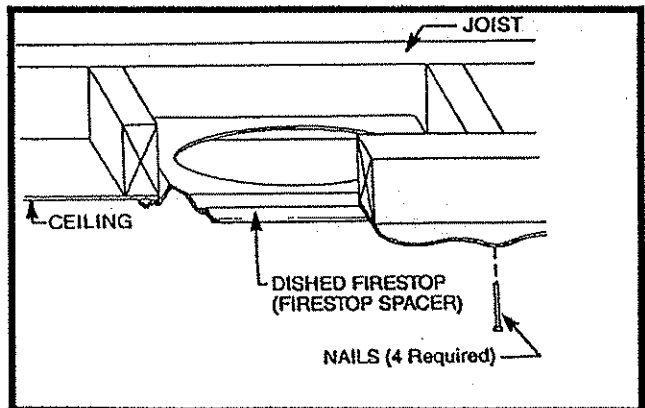

Fig. 9. Position of firestop when area above ceiling is not an attic.

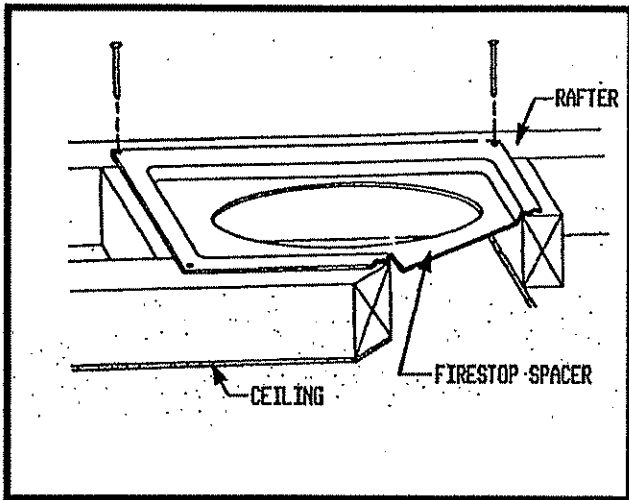

Fig. 10. Positioning of firestop when area above ceiling is an attic.

Nail each corner of the firestop spacer to the framing members of the ceiling hole. NOTE: A firestop spacer is not required at the roof.

**B-7. ATTACH CHIMNEY SECTIONS.**

Attach the first straight chimney section to the fireplace collar, or if offset installation, attach elbow to the fireplace collar. (Refer to Step B-8.) Mount the flue pipe first, using the built-in snap-lock fasteners. (See Fig. 11.) Then mount the additional pipe(s). Position each pipe section so the direction arrow is pointing UP.

**Make sure each pipe is firmly snapped and locked together as it is mounted.**

Continue installing chimney section until ONE SECTION (all pipes) extends up through the ceiling hole. To extend through the ceiling, it may be necessary to assemble all pipes, push them up through the ceiling hole and then slide them down one at a time to connect them.

**B-8. ATTACH FIRST ELBOW - OFFSET INSTALLATION.**

If the first elbow is not to be attached to the fireplace, install chimney sections as required.

Attach first elbow where required. Note that only the outer pipe snap-locks.

Attach the straps of all upper elbows to a structural framing member. (See Fig. 6.)

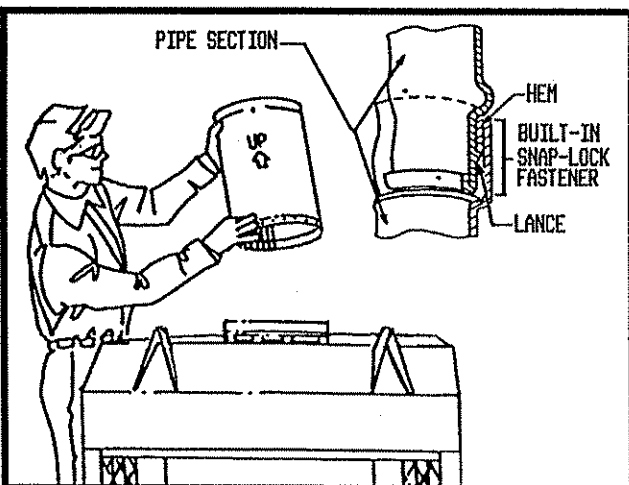

Fig. 11. Use built-in snap-lock fasteners to attach chimney pipe sections.

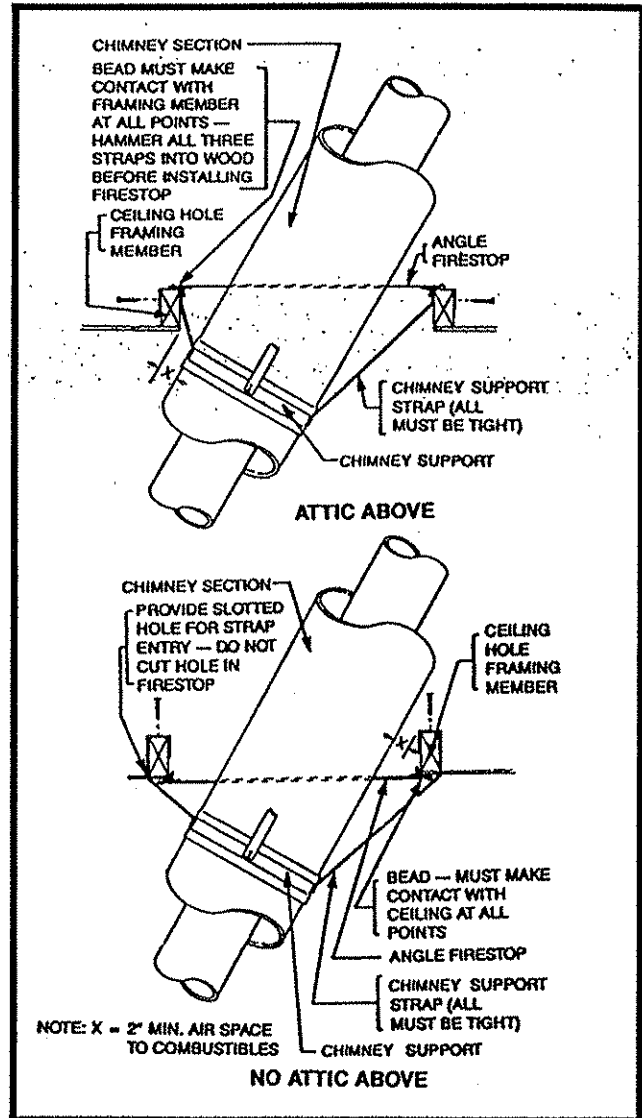

Fig. 12. Mount chimney supports at ceiling hole frames or other structural framing.

**B-9. DETERMINE HOW MANY CHIMNEY SUPPORTS ARE NEEDED.**

The chimney system is supported by the fireplace for chimney heights less than 30 feet of vertical height above the hearth. Chimney supports are required if the chimney exceeds 30 feet. Locate chimney supports at ceiling holes or other structural framing at 30 foot heights. Spacing between chimney supports must not exceed 30 feet. Use EQUUS Chimney Support Model 11CS. (NOTE: The 11CS can not be mounted directly to the fireplace.) Support provided by elbow straps fulfills the requirement only if they are spaced as required above.

Angled chimney runs require support every 6 feet in addition to the elbow straps. EQUUS chimney Supports are used for this function.

Refer to Step B-2 to determine how many chimney supports are needed and where they will be placed in the chimney run.

**NOTE:** A chimney support is 2 1/2 inches long when installed. This dimension must be considered when determining how many straight chimney sections are needed to provide the desired offset.

**B-10. INSTALL CHIMNEY SUPPORTS.**

Chimney supports are attached to chimney sections the same way elbows are attached. Refer to Step B-8. Nail the chimney support straps to adjacent structural framing, as shown in Fig. 12. Bend the straps as necessary to make sure they are tight so they will be able to support the weight of the chimney.

**B-11. LOCATE CENTERPOINT OF NEXT CEILING HOLE.**

**NOTE:** If there is no other ceiling, you have completed Section B. Turn now to Section C, Penetrating the Roof.

**B-12. PREPARE SECOND CEILING HOLE.**

Repeat Step B-3. Mark area of ceiling chimney hole; B-4, Cut ceiling chimney hole; B-5, Frame ceiling chimney holes; and B-6, Install firestop spacer.

**B-13. CONTINUE INSTALLING CHIMNEY SECTIONS.**

Continue installing chimney sections and chimney supports (as required), until the chimney passes through the second ceiling hole.

**NOTE:** Repeat steps B-11 through B-13 as many times as necessary to pass through all the ceilings in the building and bring the chimney just short of the roof.

### C. Penetrating the Roof

The chimney system must be vented out-of-doors and must be terminated in an approved EQUUS top termination.

**NOTE:** If you are using a chase, go to Section D.

**C-1. LOCATE CHIMNEY CENTERPOINT AT ROOF.**

Use the same procedure detailed in Steps B-1 and B-2.

Drive a nail up through the roof at the marked centerpoint. This will mark the centerpoint on the outside of the roof.

**C-2. CUT AND FRAME ROOF HOLE.**

The size of the roof hole varies with the type of chimney top that will be installed. Refer to the installation instructions provided with your EQUUS chimney top termination to find the correct size of roof hole for this installation. There must be at least 2 inch air space between the outermost position of the chimney sections and any adjacent combustible (burnable) surfaces.

**WARNING: DO NOT PACK REQUIRED AIR SPACES WITH INSULATION OR OTHER MATERIALS.**

(Combustible surfaces include such things as ceiling members, joists, flooring, combustible insulation and roof structures.)

Mark the outline of the roof hole around the centerpoint nail. **Note:** The hole dimensions given in the chimney top installation instructions are **horizontal** dimensions; therefore, the hole size must be marked on the roof accordingly.

Cover the opening of the installed chimney.

Cut and frame the hole. It is good practice to use framing lumber that is the same size as the rafters. **Install frame securely. Chimney top and flashing anchored to frame must withstand heavy winds.**

**C-3. DETERMINE MINIMUM CHIMNEY HEIGHT ABOVE ROOF.**

Major U.S. building codes specify minimum chimney height above the roof top. These specifications are summarized in the Ten Foot Rule. (See Fig. 13.) The key points of this rule are:

1. If the horizontal distance from the center of the chimney to the peak of the roof is 10 feet or less, the top of the chimney must be at least 2 feet above the peak of the roof, but never less than 3 feet in height above the highest point where it passes through the roof.
2. If a horizontal distance from the center of the chimney to the peak of the roof is more than 10 feet, a chimney height reference point is established that is on the surface of the roof a distance of 10 feet from the center of the chimney in a horizontal plane. (See Fig. 13.) The top of the chimney must be at least 2 feet above this reference point, but never less than 3 feet in height above the highest point where it passes through the roof.

These chimney heights are necessary in the interest of safety and do not assure a smoke-free operation.

**C-4. INSTALL REMAINDER OF CHIMNEY SECTIONS.**

Continue installing chimney sections up through the roof hole. Check your chimney top installation instructions for data on how high above the top of roof the **CHIMNEY SECTIONS** (all pipes) should go.

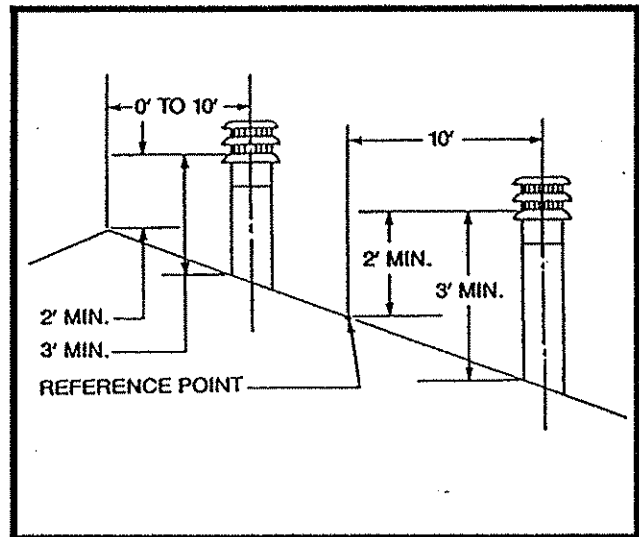

Fig. 13. Ten foot rule for chimney height.

**C-5. INSTALL CHIMNEY TOP HOUSING OR TERMINATION.**

Follow the installation instructions provided with the EQUUS chimney top you have selected.

### D. Installing Chimney in a Chase

A chase is a vertical box-like structure built to enclose the fireplace and/or its chimney.

**CAUTION:** Treatment of firestop spacers and construction of the chase may vary with the type of building. These instructions are not substitutes for the requirements of local building codes. Therefore, your local building codes must be checked to determine the requirements for these steps.

**NOTE:** Other material may be required in addition to EQUUS Firestop Spacers.



When installing a SH42 Series fireplace and chimney in a chase, it is always good building practice to **insulate the chimney chase as you would an outside wall of your home**. See Section F, which describes insulation methods.

Refer to MIFraming and Finishing on page 10. Upon completion of building your chase frame, install the chimney system. Follow the instructions for *Installing the Chimney* starting on page 4. Then proceed to Step D-1.

**D-1. INSTALL FLASHING AND CHIMNEY TOP.**

Follow the installation instructions provided with the EQUUS chimney top you have selected.

**E-1. INSTALL OUTSIDE AIR KIT.**

Install outside air kit if desired or required by local code. Refer to AK-MST installation instructions supplied with the appropriate kit. This kit **MUST** be installed before the fireplace is enclosed.

**F. Insulating Fireplace Enclosure for Cold Climates**

When installing the fireplace, it is always good building practice to **insulate as you would an outside wall of your home**.

In cold climates, insulation of the enclosure around the fireplace is critical to avoid future problems with cold air. The following steps are suggested to minimize potential cold air problems.

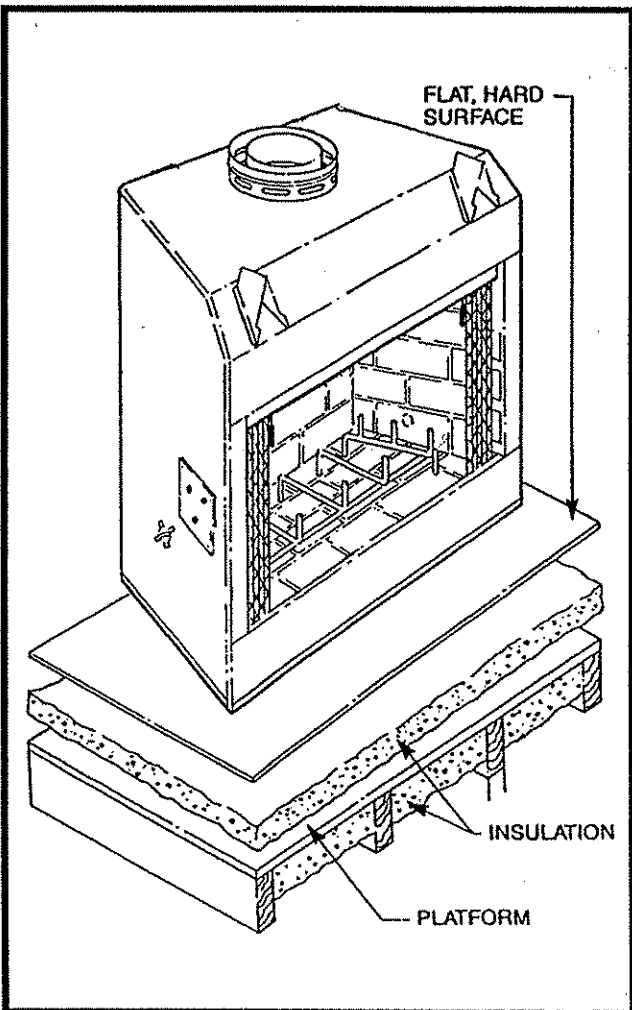

Fig. 14. Insulation between platform and fireplace.

**F-1. INSULATE BASE OF FIREPLACE.**

Insulate the base of the fireplace with a non-combustible insulation rated for a minimum of 300°F. This step is particularly important for outside wall installation over concrete slab floor construction. If a platform is used to raise the fireplace, the insulation should be placed on top of the platform before the fireplace is set. (See Fig. 14.)

**F-2. INSPECT JOINTS.**

Inspect joints of the fireplace as well as the points of sealing between the fireplace and the finishing materials. Any cracks should be sealed with non-combustible caulking or insulation. See Fig. 15 for details of sealing spaces between the fireplace and finishing materials.

**F-3. INSULATION OF ENCLOSURE.**

When a fireplace is installed in a chase or on an outside wall, the enclosure should be insulated like any other wall of the home. Insulation should be installed on the inside wall as well as the outside wall(s). In a chase, it is also a good idea to install a firestop at the first ceiling level above the fireplace and close the chase with sheeting material. Insulation may then be installed above the sheeting material to assure the space around the fireplace is totally protected. See Fig. 16 for additional details of suggested insulating methods.

**CAUTION: WHILE INSTALLING A FIREPLACE IN AN INSULATED ENCLOSURE, BE SURE ALL MARKED AIR SPACES ARE MAINTAINED.**

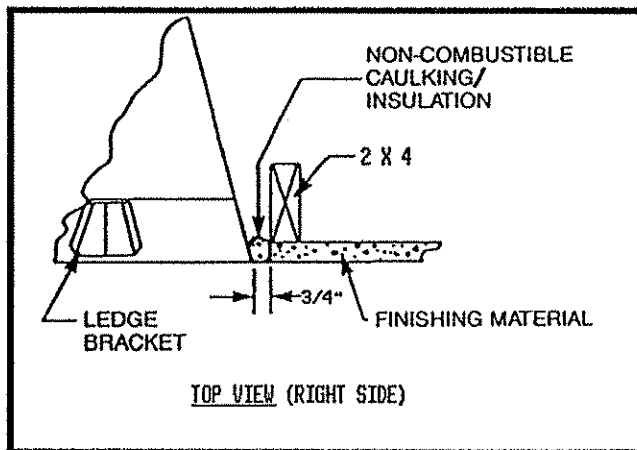

Fig. 15. Sealing spaces between fireplace and finishing materials.

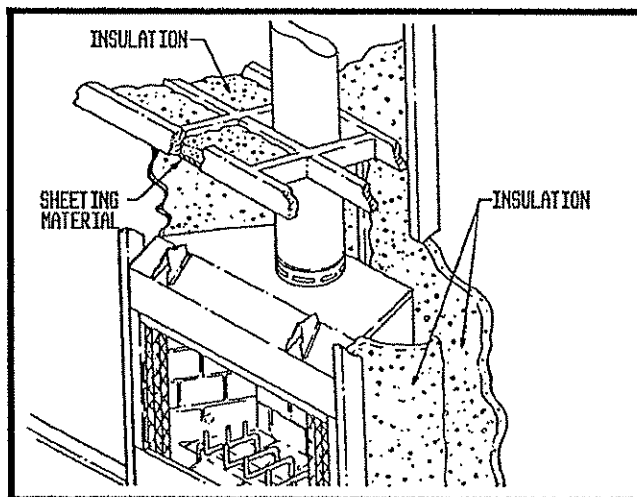

Fig. 16. Additional insulating methods.

## G. Framing and Finishing

### G-1. DETERMINE WHEN TO INSTALL FRAMING.

Fireplace framing can be built before or after the fireplace is set in place. Figure 17 shows the minimum framing dimensions.

### G-2. BUILDING FRAMING.

The fireplace framing should be constructed of 2 X 4 lumber or heavier. Refer to *Dimensions* on page 14 for basic fireplace dimensions that will affect the framing dimensions.

The header may rest on the top of the fireplace ledge brackets.

Framing should be positioned to accommodate wall covering and fireplace facing material. (See Figs. 18, 19, 20 and 21 for typical arrangements.) Fastening tabs provided on the side of the fireplace basepan can be used to anchor the fireplace. Nail through the tabs into the floor. (See Fig. 4.)

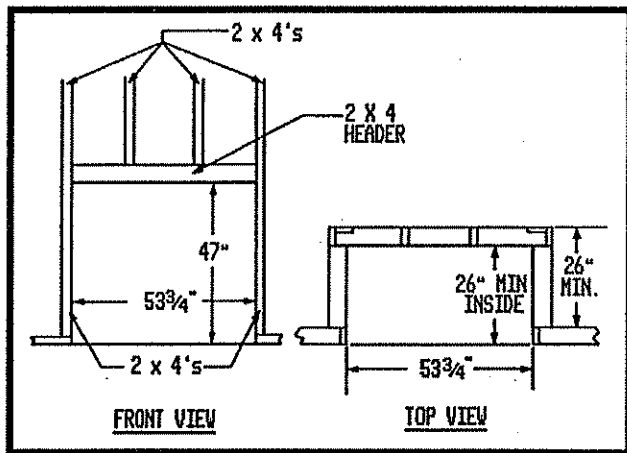

Fig. 17. Minimum fireplace enclosure dimensions.

**CAUTION:** All joints between the finished wall and the fireplace surround (top and sides) must be sealed with non-combustible material.

### G-3. FINISH WALL.

Finish the wall with material of your choice. Do not install a combustible mantel closer than 12 inches above fireplace opening for SH42. If a combustible material is used below a flat mantel shelf, consult your local building codes for the minimum clearance from the top of the fireplace opening to the bottom of the material.

When finishing the fireplace, a combustible facing material (i.e. drywall or wood paneling) may be installed at the fireplace surround top as shown in Figure 18. This material may rest on the ledge brackets, but must NOT be notched to fit around them.

All joints (top, bottom and sides), where the wall or decorative facing material meets the fireplace surround must be completely sealed with a non-combustible material. (See Figs. 18, 19, 20 and 21.)

Only non-combustible material may be applied as facing to the black fireplace surround.

When finishing the fireplace, never obstruct or modify the air inlet/outlet grilles in any manner. (See Fig. 21.)

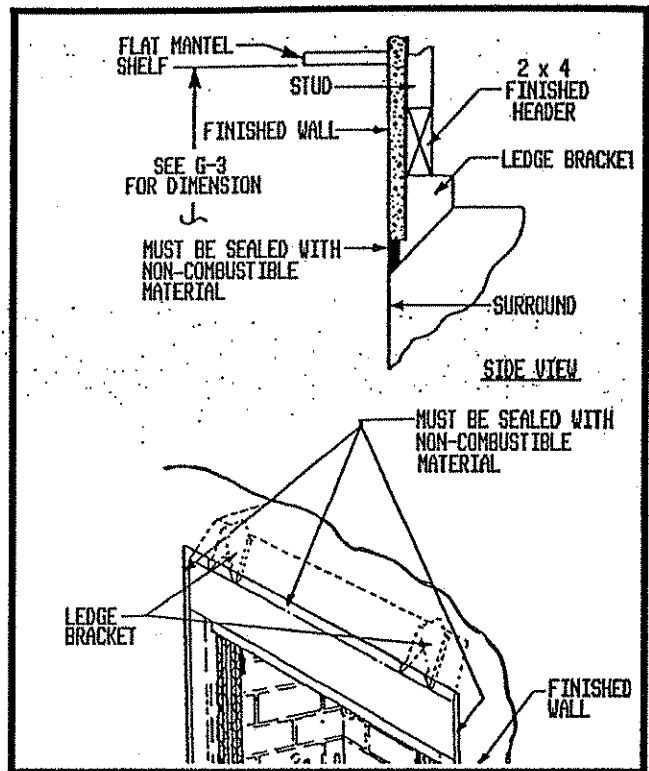

Fig. 18. Fireplace surround flush with finished wall.

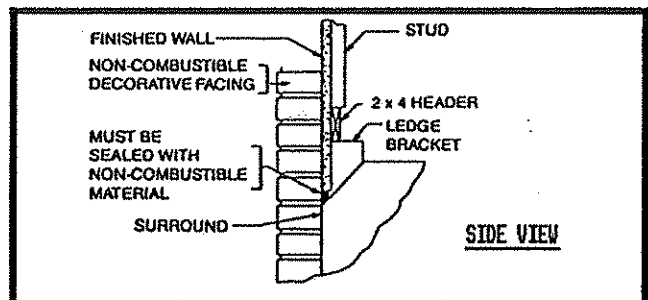

Fig. 19. Fireplace surround flush with finished wall.

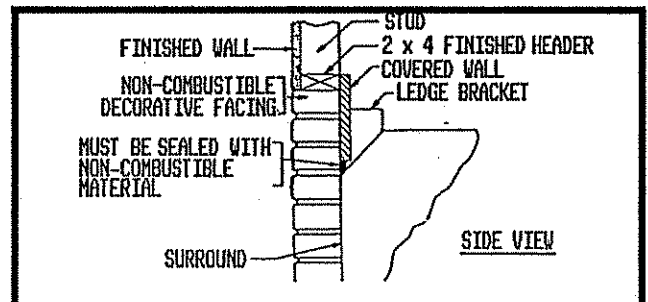

Fig. 20. Facing on fireplace surround flush with finished wall.

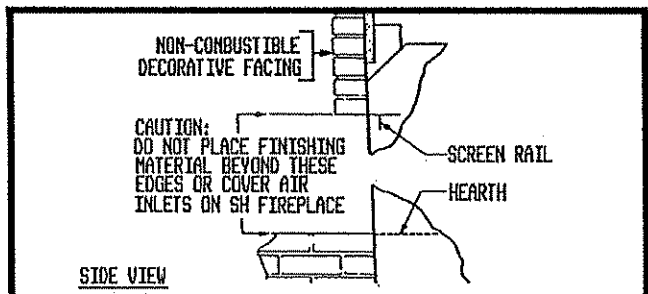

Fig. 21. Finishing front of fireplace.

**NOTE:** For fireplaces installed at 45 degrees to two side walls (corner installation), no side wall protection is required.

**G-4. ADD PROTECTION TO SIDE WALLS.**

Adjacent combustible side walls that are within 22" of the fireplace openings must be protected with EQUUS Wall Shield Model SP40, or a built-up wall shield described in Fig. 22. (See Figs. 22 and 23.)

The built-up wall shield design described in Fig. 22 is an alternate method for adding protection to side walls and can be used in place of the SP40 with the same wall clearances specified for the SP40.  $R_T$  must = 1.85 min.

**EXAMPLES OF INSULATION:**

1. Manville - CERAFORM 126,  $K = .27$ ; 1/2" thick required.
2. Equus Building Products - EH2416,  $K = .458$ , 1" thick required.

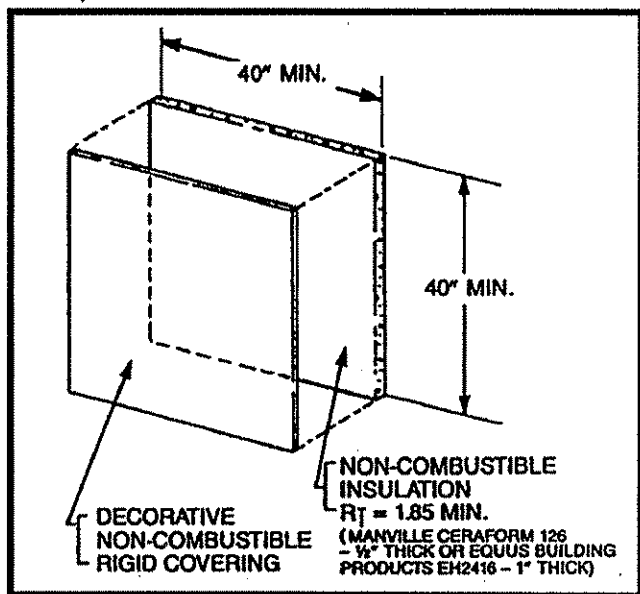

Fig. 22. Non-combustible wall shield dimensions.

**G-5. INSTALL HEARTH EXTENSION.**

A hearth extension is required to protect combustible floor construction in front of the fireplace. See Fig. 23 for minimum dimensions and mounting detail.

The hearth extension described in Fig. 23 must be constructed of a rigid insulation with a minimum (total)  $R_T$  value of 2.18. (See Table 4 for examples.) The overall height (above combustible floor), depth and width must be as indicated, with it centered to the fireplace opening. (See Fig. 23.)

MATERIAL	K*	R	MINIMUM THICKNESS
EQUUS Building Products EH2416	0.458	2.18	1.00**
Common Brick	5.0	0.20	10.92

R Value is for one (1) inch  
 \* Units of K = BTU/SQ FT/HR<sup>2</sup>F/IN  
 \*\* Thickness of Listed Material

Table 4. Common materials and their factors.

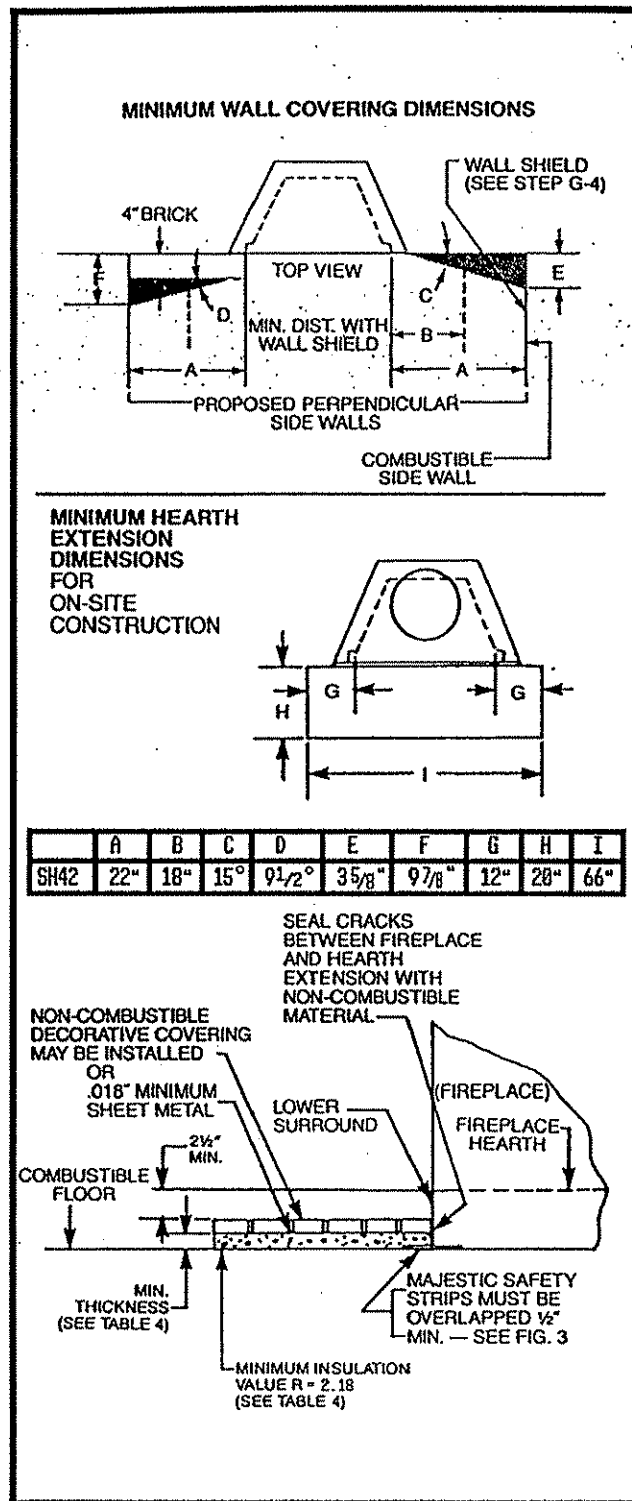

Fig. 23. Protection of adjacent combustible side walls and hearth extension dimensions.

The top of the insulation must be covered with a non-combustible decorative covering or a piece of .018" minimum sheet metal, to protect the hearth extension material. (See Fig. 23.)

Secure the hearth extension to the floor to prevent shifting, using trim molding or other similar means at the three (3) outer edges. Seal the crack between the fireplace hearth and the hearth extension with a non-combustible material. (See Figs. 23, 24 and 25.)

**WARNING: HEARTH EXTENSION MUST BE INSTALLED IN ACCORDANCE WITH FIGS. 23, 24 AND 25 .**

Alternate, non-combustible materials may be used providing the (total) thermal resistance ( $R_T$  value) of the alternate material employed is greater than or equal to an  $R = 2.18$ . The thermal resistance ( $R$ ) or the thermal conductivity ( $K$ ) may be obtained from the manufacturer of the material. The factors are related by the formula  $K = 1/R$ .

$T$  = given thickness

$R$  = thermal resistance for a given thickness ( $T$ )

$K$  = thermal conductivity

Non-combustible material with a lower  $R$  value may be used, provided the thickness of the material is sufficiently greater to maintain an equivalent (total) thermal resistance ( $R_T$ ).

**EXAMPLES OF DETERMINING HEARTH EXTENSION EQUIVALENT**

To determine the thickness required for any new material:

$$\frac{\text{NEW thickness required} \times K \text{ of new material (per inch)}}{\text{thickness of listed material} \times K \text{ of listed material (per inch)}} = X$$

**EXAMPLE FOR COMMON BRICK**

$$T \text{ (new)} = 5.0 / 0.458 \times 1.00 \text{ in.} = 10.92 \text{ in. (new required thickness)}$$

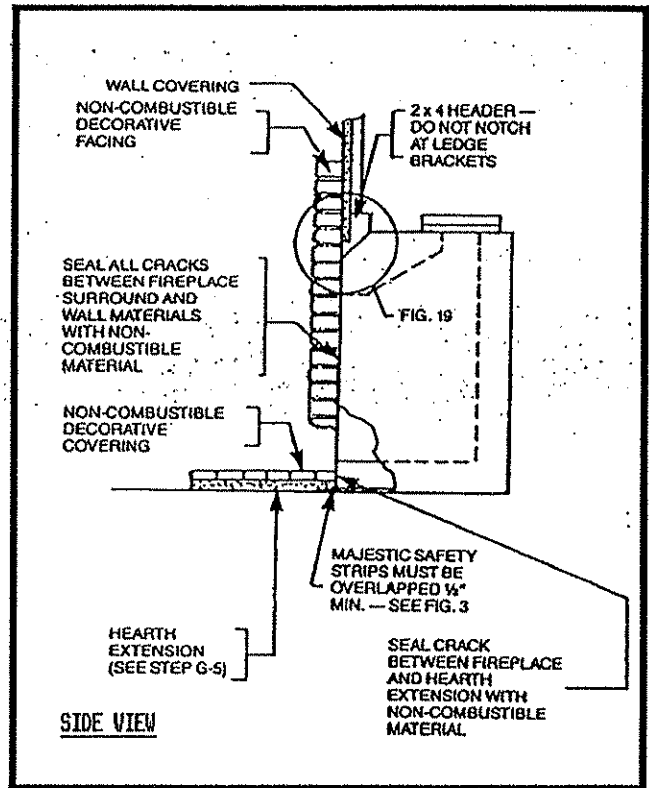

Fig. 25. Sealing detail.

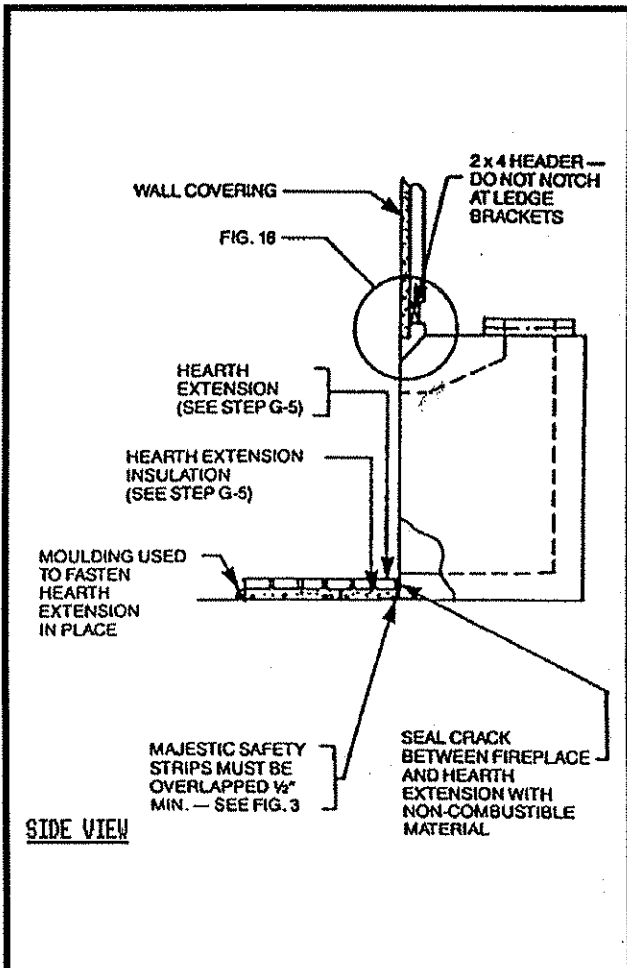

Fig. 24. Sealing detail.

**G-6. INSTALL DECORATIVE GAS APPLIANCE.**

The Majestic SH42 Series fireplace is designed to accept a 1/2 inch gas line for an approved gas appliance. Have the appliance installed by a qualified plumber in accordance with all building codes. The gas connection may enter from either side of the fireplace.

Locate the gas line hole in the outer casing of the fireplace and remove the insulation from the gas line tube. (Refer to Fig. 26.)

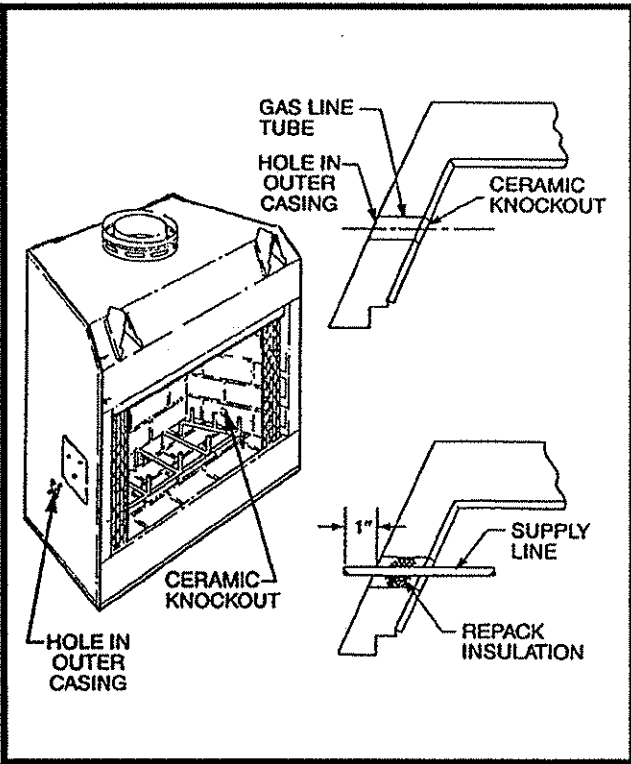

Fig. 26. Install iron pipe gas line through hole provided in either side of the fireplace.

Next, insert a 1/2 inch gas pipe through the gas line tube from the outside of the fireplace and forcibly punch out the ceramic knockout on the inside of fireplace.

Now, install the 1/2 inch gas pipe through the opening. After the gas pipe installation is complete, use the insulation that was removed from the gas line tube to repack the space around the pipe. This should be inserted from the outside of the fireplace and packed tightly to totally seal between the pipe and the tube.

**NOTE:** The gas pipe should not come in contact with any wood structures until it has reached a point at least one (1) inch away from the fireplace side. (See Fig. 26 for installation clarification.)

**NOTE:** Local codes may require removal of the flue damper when installing any type of gas appliance in a fireplace. For instruction on damper removal, refer to Majestic Instruction BF151. Heat output of a gas appliance installed in the fireplace should be rated less than 100,000 BTU/Hr.

The gas pipe installation is intended for connection to a decorative gas appliance only (1) incorporating an automatic shutoff device and (2) complying with the Standard for Decorative Gas Appliances for Installation in Vented Fireplaces, ANSI Z21.60.

The decorative gas appliance should be installed in accordance with the National Fuel Gas Code, ANSI Z223.1-1988.

**CAUTION: WHEN USING DECORATIVE GAS APPLIANCE, THE FLUE DAMPER MUST BE SET IN THE FULLY OPEN POSITION.**

**Reference Data**

**AIR SPACE DATA**

Any Majestic SH42 Series fireplace can be located directly on a flat hard-surfaced combustible floor or on a wooden platform without air space from combustible construction. Some protection, however, is required for adjacent surfaces as detailed in Fig. 27.

The minimum air space-to-combustibles requirements for chimney sections and dome are detailed in Fig. 27.

**WARNING: DO NOT PACK REQUIRED AIR SPACED WITH INSULATION OR OTHER MATERIALS.**

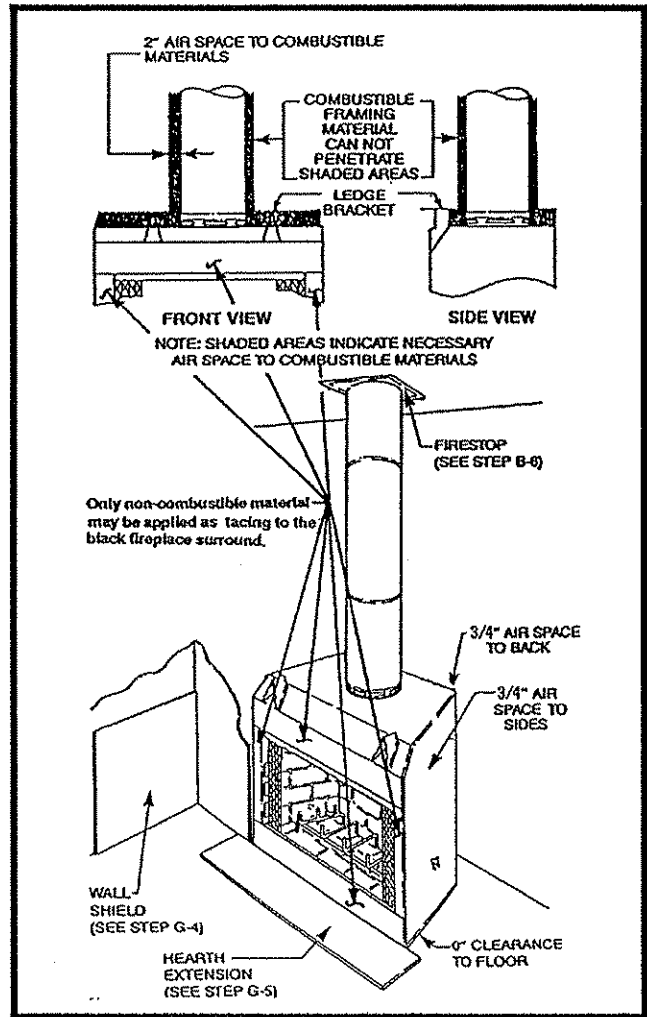

Fig. 27. Minimum air spaces to combustible materials.

# DIMENSIONS

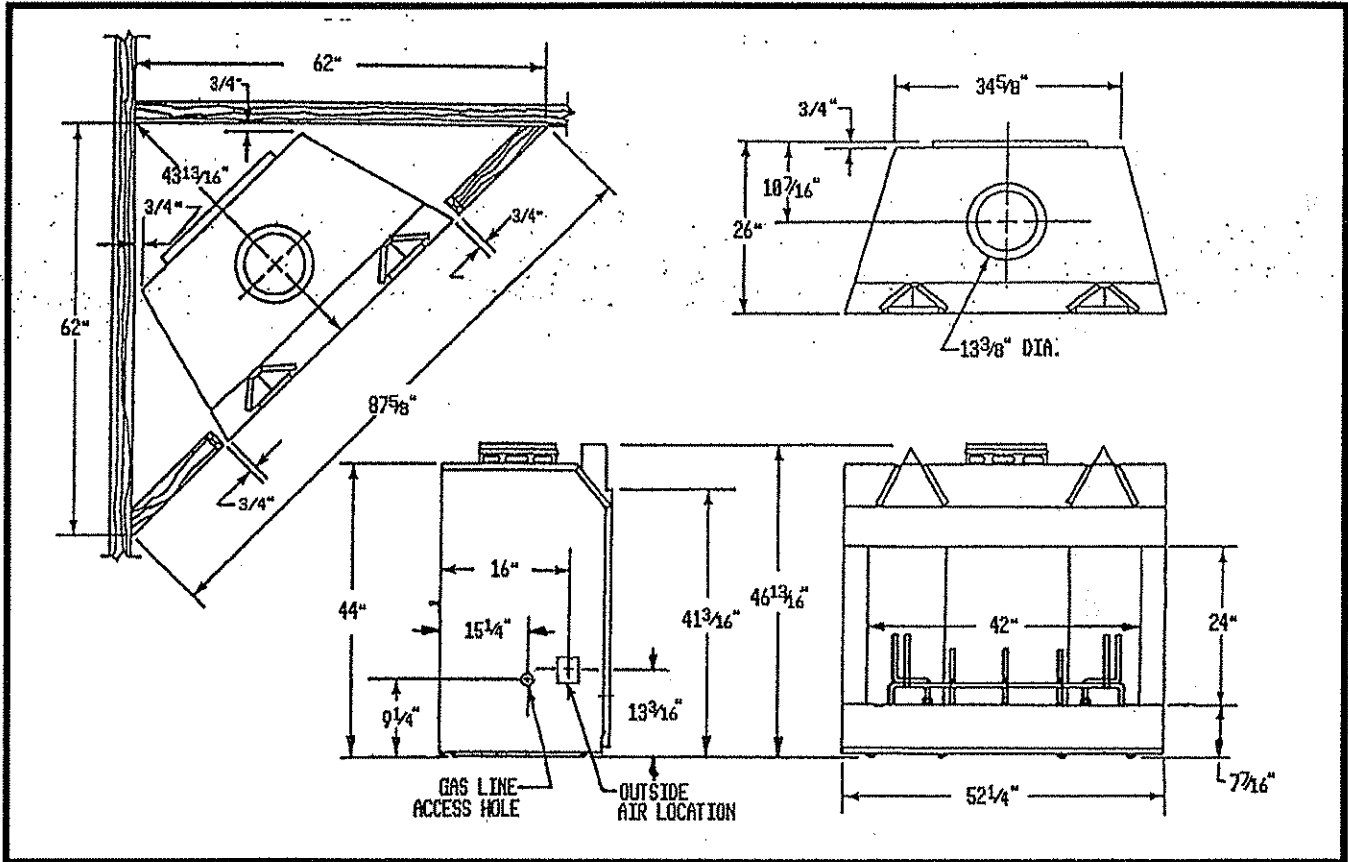



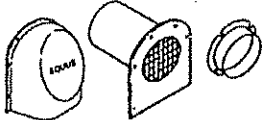
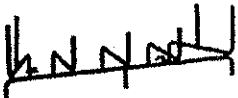



Fig. 28. Dimensions of SH42.

## Accessory Parts







The following accessory parts can be obtained from your Majestic Dealer. The fan kit, top terminations, outside air kit, glass doors, and hearth patching kits are supplied with installation instructions packaged with the unit. Should you need additional information beyond what your dealer can furnish, contact the Majestic Company, Huntington, Indiana 46750, Attention: Director of Customer Service.

**CAUTION: This fireplace and chimney assembly is a highly engineered system and, as such, must be operated only with Majestic or Equus Building Products approved components that have been designed as parts of the system. If you use an unapproved component or make any modifications, you may create a possible fire hazard and will void the Majestic warranty. In addition, such action may void the coverage provided by the owner's home insurance.**

### SECTION 1

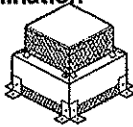
Accessory	Description	Model No.
<p><b>Glass Enclosure Kit</b></p> 	<p>Designed to enclose the fireplace opening with glass doors allowing the fire to remain visible.</p>	<p>SHGD-II</p>
<p><b>Air Kit</b></p> 	<p>Designed to provide outside air for fuel combustion in the firebox. This accessory <b>must</b> be installed before the fireplace is installed.</p>	<p>AK-MST</p>
<p><b>Baslet Grate</b></p> 	<p>Used in the firebox to hold firewood.</p>	<p>Standard Equipment ----- Replacement RBGSH42</p>
<p><b>Hearth Extension</b></p> 	<p>Located on the floor in front of the fireplace opening to protect the floor from heat, hot embers, ashes, etc.</p>	<p>EH2416</p>
<p><b>Wall Shield</b></p> 	<p>Used to protect walls adjacent to the fireplace.</p>	<p>SP40</p>
<p><b>Firestop</b></p> 	<p>Required at each floor level and attic on multi-story installation.</p>	<p>FS2A (straight flue) FS6A (30° inclined flue)</p>
<p><b>Hearth Patching Kit</b></p>	<p>Used to patch cracks in hearth.</p>	<p>HPC1</p>

## SECTION 1 (Continued)

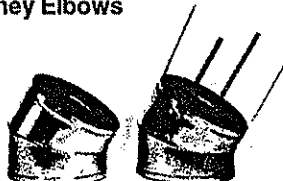
Accessory	Description	Model No.
<p><b>Chimney Support</b></p> 	<p>Used to support the chimney at each 30 feet of vertical height above the hearth and at every 6 feet of inclined chimney run. Each support adds 2 1/2 inches to chimney length.</p>	<p>11CS (11" flue)</p>
<p><b>Contemporary</b></p> 	<p>Required for contemporary top termination on the roof to prevent rain entry.</p>	<p>8-6-12 (0 to 6/12 pitch) 8-12-12 (6/12 to 12/12 pitch)</p>
<p><b>Contemporary Top Chase Termination</b></p> 	<p>Used to terminate Model 11CF chimney at the top of a chase. Adapter kit is included, flashing is not included.</p>	<p>TT11</p>
<p><b>Contemporary Round Top Termination</b></p> 	<p>Used to terminate chimney on the roof. Flashing not included.</p>	<p>RT11 (11" flue)</p>
<p><b>Extended Round Top</b></p> 	<p>Used to terminate chimney at the top of a chase. Adapter kit included. Flashing not included.</p>	<p>RTL11 (11" flue)</p>
<p><b>Chimney Sections</b></p> 	<p>Used to build chimney systems</p>	<p>(11" flue) 11CF1 (1' long) 11CF18 (1 1/2' long) 11CF3 (3' long) 11CF4 (4' long)</p>
<p><b>Chimney Elbows</b></p> 	<p>Used to develop 30° offset chimney systems. (Elbows packed 2 per carton - upper and lower elbow set.)</p>	<p>11CF30-2 (11" 30° flue)</p>



**NOTES:**





**MAJESTIC**  
A Division of Majco Building Specialties, L.P.  
Huntington, IN 46750-2579 (219) 356-8000

LISTED FOR RESIDENTIAL CONSTRUCTION: SH42  
• UNDERWRITERS LABORATORIES REPORT NO. MH6018



Underwriters' Laboratories, Inc.

SH Series Fireplaces are covered by Mechanical Patent No. 4,519,376

74-12-444 SH42II/789